

Visium HD FFPE Tissue Preparation Handbook 2.0

Introduction

The Visium HD Spatial Gene Expression workflow (protocol 2.0) is designed to analyze mRNA in tissue sections derived from formalin fixed & paraffin embedded (FFPE) tissue samples. This workflow is facilitated via the Visium CytAssist instrument, which enables the capture of ligated probe products onto the Visium HD Slide (6.5 mm or 11 mm). A single Visium CytAssist run accommodates up to two stained tissue slides (tissue placed on a blank slide) as sample input. Proper tissue handling and preparation techniques preserve the morphological quality of the tissue sections and the integrity of mRNA transcripts. Maintaining tissue adhesion and high-quality RNA is critical to assay performance.

This FFPE Tissue Handbook provides guidance on:

- Removing hardset coverslips from archived tissue slides
- Performing RNA quality assessment and optional morphological and RNA quantity per cell assessments of FFPE tissue blocks or archived Hematoxylin & Eosin (H&E) stained tissue sections on tissue slides
- Sectioning of tissue blocks and placement of sections on blank slides
- H&E Staining and imaging
- Immunofluorescence (IF) Staining and imaging

Additional Guidance

This protocol is compatible with most human and mouse tissue types. Modifications to the sample preparation protocol such as section flotation time and water bath temperature may be required for the preparation of certain tissue blocks such as breast, colon, skin, and lung. Additional recommendations are also provided to minimize the risk of tissue detachment when working with tissue blocks that have large amounts of connective tissue such as breast or colon. See the 10x Genomics Support website for additional resources, including a list of tissues tested.

Contents

Handbook Overview and Navigation

Overview	4
----------	---

Visium HD Spatial Gene Expression Reagent Kits

Visium HD Spatial Gene Expression Reagent Kits	5
10x Genomics Accessories	8
Third-Party Items	9

Tips & Best Practices

RNA Quality Assessment	10
Section Thickness	11
Section Placement on Blank Slides	11
Practice Section Placement	12
Optional - Area of Interest Annotation	13
Lint-free Laboratory Wipes	15
Handling Tissue Slides	16
Tissue Slide Incubation	17
Cassette Incubation	18
Reagent Addition to & Removal from Wells	19
Visium Slide Seal Application & Removal	20
Visium CytAssist Alignment Aid	22

1. Archived Slide Processing

1.0 Preparation	27
1.1 Hardset Coverslip Removal and Slide Processing	29
1.2 RNA Extraction	32
1.3 Destaining	34
1.4 Decrosslinking	36

2. Tissue Handling, FFPE Tissue Sectioning, Section Placement, and Quality Assessment

2.0 Exposing the Tissue or Facing the Block	45
2.1 RNA Quality Assessment of FFPE Tissue Block	46
2.2 Sectioning	48
2.3 Section Placement	50
2.4 Optional DAPI Staining for Tissue Morphology Assessment	53
2.5 Optional H&E Staining for Tissue Morphology Assessment	54
2.6 RNA Quantity per Cell Estimation	56

3. H&E Staining & Imaging	
3.0 Get Started	60
3.1 Protocol Overview	63
3.2 Deparaffinization	66
3.3 H&E Staining	68
3.4 Coverslip Mounting	69
3.5 Imaging	70
3.6 Coverslip Removal	70
3.7 Destaining	71
3.8 Decrosslinking	74
4. IF Staining & Imaging	
4.0 Get Started	81
4.1 Protocol Overview	85
4.2 Deparaffinization	89
4.3 Decrosslinking	91
4.4 Immunofluorescence Staining	94
4.5 Immunofluorescence Staining - Fluorophore Conjugated Primary Antibodies	94
4.6 Immunofluorescence Staining - Primary & Secondary Antibodies	98
4.7 Coverslip Mounting	103
4.8 Imaging	103
4.9 Coverslip Removal	104

Troubleshooting

Appendix

Handbook Overview and Navigation

Overview

This handbook describes sample preparation for the Visium HD Spatial Gene Expression workflow. Tabs on the right-hand side of the page denote different sections. Two sample types are compatible with the workflow: archived slides and freshly placed FFPE sections.

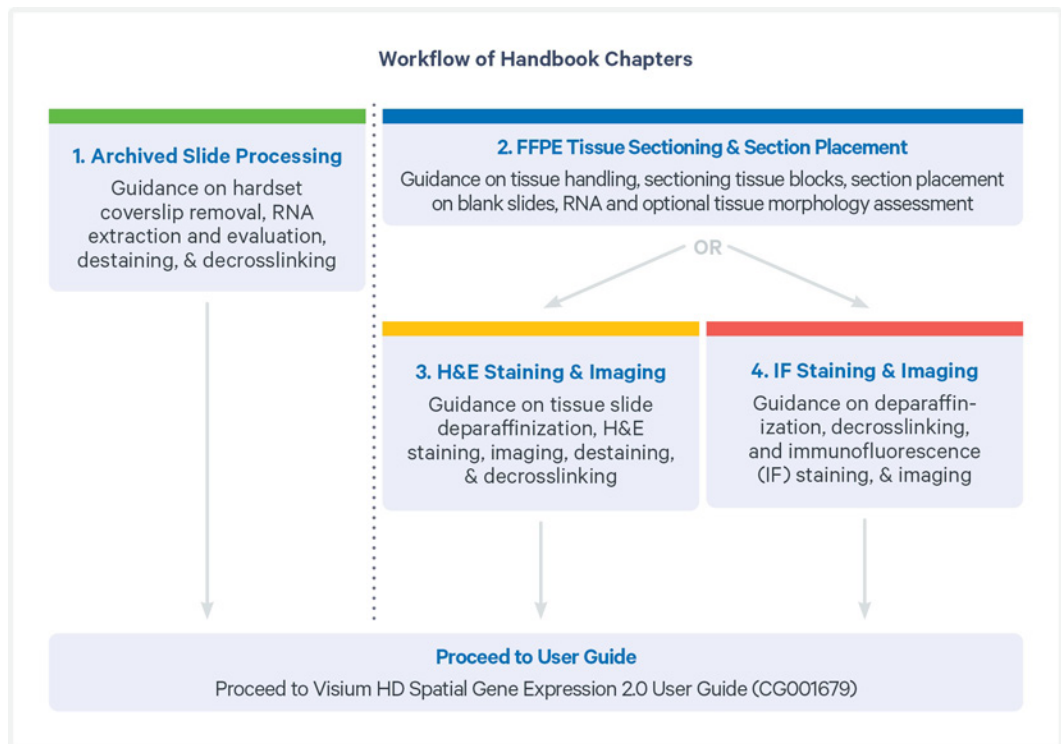

Archived Slides

Section one covers processing archived slides that were previously H&E stained and imaged. Archived slides have their coverslips removed, RNA assessed, and are destained and decrosslinked. After decrosslinking, slides are ready for the Visium HD workflow.

Freshly Placed FFPE Sections









Section two covers sectioning and placement of FFPE tissue sections onto blank slides. After section placement, proceed to either section three for H&E staining or section four for IF staining. After completing either staining protocol, slides are ready for the Visium HD workflow.

Visium HD Spatial Gene Expression Reagent Kits

Consult SDS for handling and disposal information

Visium HD Spatial Gene Expression Reagent Kits

Visium HD Reagent Kit – Small, PN-1000668

Visium HD Reagent Kit – Small PN-1000668 <i>Shipped on dry ice; Store at -20°C</i>					
Cap Color	Reagent	PN	Cap Color	Reagent	PN
	Decrosslinking Buffer B	2001094	-	empty	-
	RNase Enzyme	3000605		2X RNase Buffer	2000411
	Perm Enzyme B	3000553	-	empty	-
	Extension Enzyme	2000389		Extension Buffer	2000409
	TS Primer Mix B	2000537		Amp Mix B	2000567
-	empty	-	-	empty	-

RNase Inhibitor 40X – PN-1000887

RNase Inhibitor 40X PN-1000887 (store at -20°C)			
		#	PN
	RNase Inhibitor 40X	1	2001488

Visium HD Cassettes, 6.5 mm, 4 rxns PN-1000669

Visium HD Cassettes, 6.5 mm 4 rxns PN-1000669 (store at ambient temperature)		
	#	PN
Visium 2-port Cassette S3, 6.5 mm		
Visium Cassette 2-port gasket, 6.5 mm	2	3002329 or 3001831
Visium Cassette Bottom	2	3002328 or 3001830
Visium Tissue Slide Cassette S3, 6.5 mm		
Tissue Slide Cassette Top	4	3002327 or 2001343
Movable Tissue Gasket, 6.5 mm (preassembled with translator)	4	3001828
Movable Tissue Gasket Translator (preassembled with gasket)	4	3002330 or 3001927
Tissue Slide Cassette Bottom	4	3002326 or 3001825
Visium Slide Seals, 12 pack	2	2000283

Visium HD Cassettes*, 11 mm, 2 rxns PN-1000849

Visium HD Cassettes, 11 mm 2 rxns PN-1000849 (store at ambient temperature)		
	#	PN
Visium 2-port Cassette S3, 11 mm		
Visium Cassette Top 11 mm	1	3001832 or 3002880
Visium Cassette Bottom	1	3002328 or 3002894
Visium Tissue Slide Cassette S3, 11 mm		
Universal Tissue Slide Cassette Top, 11 mm	2	3002327
Movable Tissue Gasket, 11 mm	2	3001829
Universal Tissue Slide Cassette Bottom, 11 mm	2	3002326
Visium Slide Seals, 12 pack	1	2000283

*The Visium HD Workflow is run with Visium Tissue Slide Cassettes S3 and Visium Cassettes S3. These are referred to as Tissue Slide Cassettes and Visium Cassettes in this document, respectively. Consult the Visium S3 Tissue Slide Cassette Assembly Quick Reference Card (CG000730) for assembly and disassembly information.



Items from one cassette kit should not be used interchangeably with items from other cassette kits. To minimize the risk of mixing parts, always store all items in the original cassette kit box.

Visium 8-port Cassette S3, 4 pk PN-1000685

Visium 8-port Cassette S3 4 pk PN-1000685 (store at ambient temperature)		
	#	PN
8-port Gasket Top	4	3001827
Tissue Slide Cassette Bottom	4	3001825



A Visium 8-port Cassette S3, 4 pk (PN-1000685) must be purchased to perform antibody optimization prior to IF staining.

Visium Tissue Slide Cassette S3, 6.5 mm, 4 pk PN-1000684

Visium HD Tissue Slide Cassette S3, 6.5 mm 4 pk PN-1000684 (store at ambient temperature)		
Visium Tissue Slide Cassette S3, 6.5 mm	#	PN
Tissue Slide Cassette Top	4	3001826 or 3002327
Movable Tissue Gasket, 6.5 mm (preassembled with translator)	4	3001828
Movable Tissue Gasket Translator (preassembled with gasket)	4	3001927 or 3002330
Tissue Slide Cassette Bottom	4	3001825 or 3002326

Visium HD Tissue Slide Cassette, 11 mm, 2 pk PN-1001030

Visium HD Tissue Slide Cassette, 11 mm 2 pk PN-1001030 (store at ambient temperature)		
	#	PN
Visium Tissue Slide Cassette S3, 11 mm		
Tissue Slide Cassette Top, 11 mm	2	3002327
Movable Tissue Gasket, 11 mm	2	3001829
Tissue Slide Cassette Bottom	2	3002326



One additional Tissue Slide Cassette (Visium Tissue Slide Cassette S3 6.5 mm, 4 pk PN-1000684 or Visium Tissue Slide Cassette, 11 mm, 2 pk PN-1001030) is required for each processed Tissue Slide.

10x Genomics Accessories

Visium CytAssist Alignment Aid Kit, 6.5 mm PN-1000886

Visium CytAssist Alignment Aid, 6.5 mm PN-1000886 (store at ambient temperature)		
	#	PN
Visium CytAssist Alignment Aid, 6.5 mm	1	3002814



Visium CytAssist Alignment Aid Kit, 11 mm PN-1000940

Visium CytAssist Alignment Aid, 11 mm PN-1000940 (store at ambient temperature)		
	#	PN
Visium CytAssist Alignment Aid, 11 mm	1	3002856



Visium CytAssist Reagent Accessory Kit PN-1000499

Visium CytAssist Reagent Accessory Kit PN-1000499 (store at ambient temperature)		
	#	PN
10x Magnetic Separator	1	2001212
Low Profile Thermocycler Adapter	2	3000823



Third-Party Items

Successful execution of the Visium HD workflow requires third-party reagents, kits, and equipment in addition to those provided by 10x Genomics. All third-party reagents and consumables should be obtained prior to starting this workflow.

Consult the Visium HD Spatial Gene Expression Protocol Planner (CG000698) for a list of the following third-party items:

- Additional reagents, kits, and equipment
- Tested pipette tips
- Tested thermal cyclers
- Tested blank slides



10x Genomics has tested all items listed in the Protocol Planner. Unless otherwise noted, 10x Genomics recommends using these items to ensure optimal assay performance. Substituting materials may adversely affect assay performance.

Tips & Best Practices

Icons



Tips & Best Practices section includes additional guidance



Signifies critical step requiring accurate execution



Troubleshooting section includes additional guidance



Protocol 2.0-specific instruction

Sample Preparation

- Store FFPE tissue blocks at 4°C and avoid exposure to direct light to ensure even chilling and preservation of RNA integrity.

RNA Quality Assessment

- Assess RNA quality of the tissue block or archived sections by calculating the percentage of total RNA fragments > 200 nucleotides (DV200) of RNA extracted from tissue sections. For archived sections, this involves scraping off a section of tissue from the slide for RNA extraction. For fresh sections, RNA quality is assessed from a section taken from the tissue block prior to section placement.
- A column-based method of RNA isolation should be used. Alternate methods of RNA isolation may affect score.
- Various factors could lead to variations in DV200 scores, such as:
 - Specific tissue types
 - Tissue heterogeneity
 - Diseased or necrotic tissues
 - Sample preparation and handling
 - Loading concentration or ladder errors on the RNA QC platform
- 10x Genomics recommends that the tissues used with the Visium HD Spatial Gene Expression should have a DV200 of > 30%. Low DV200 scores do not necessarily result in poor data, but high scores are more likely to correlate with higher sensitivity.

Section Thickness

- Recommended section thickness is 3–10 μm . Though the entire recommended range of thicknesses was tested internally, most sections were cut at 5 μm , the thickness referenced throughout this protocol.

Water Bath Temperature & Section Floating Time

- Optimal water bath temperature and section floating time are critical for tissue section expansion. 42°C is the recommended water bath temperature for most tissues. However, water bath temperature may need optimization based on the tissue type.
- If the tissue is taking too long to expand, turn the water bath temperature up by 1 or 2 degrees and let the section float for longer.
- If the tissue is expanding too quickly and dissociating, turn the water bath temperature down by 1 or 2 degrees and shorten the floating time.
- Clean water bath according to manufacturer recommendations, followed by an RNase decontamination solution.

Section Placement on Blank Slides

- Inspect slides prior to tissue placement for particles and fibers. If found, remove with a lint-free laboratory wipe or compressed air. If using compressed air, do not introduce moisture to the slides.
- After section placement, blank slides are referred to as tissue slides.
- Before section placement, draw an outline of the allowable area on the back of the blank slide to ensure compatibility with the Visium CytAssist instrument and Tissue Slide Cassette, as shown below. Example allowable area images below are not to scale.

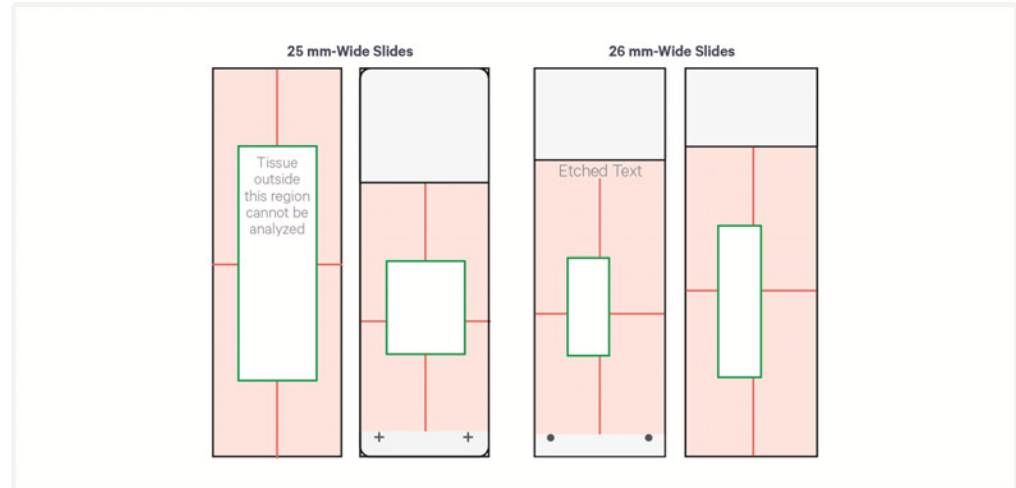

Consult the Visium CytAssist Tissue Slide Alignment Instruction, Quick Reference Cards (CG000548) on the 10x Genomics support website for complete instructions on determining allowable area. Consult the Visium HD Spatial Gene Expression Protocol Planner (CG000698) for a list of tested slides.

- If placing multiple sections on a blank slide, ensure that the paraffin and/or tissue do not overlap.
- If working with sections on multiple tissue slides, ensure that sections are placed in the same location on the tissue slides for improved imaging efficiency.
- Each tissue slide can only be processed with the Visium CytAssist instrument once.

Practice Section Placement

- Practice correct section placement using nonexperimental blocks.
- Practicing section placement also allows for determining an ideal tissue thickness for the tissue type or block.
- Sections should be placed on compatible blank slides listed in the Visium HD Spatial Gene Expression Protocol Planner (CG000698).

Section Attachment

- Tissue block and section quality can affect the section attachment to blank slides.

- Choice of blank slide may influence section attachment. Review the Tested Tissues List for recommendations on slides for specific tissues.
- 10x Genomics recommends placing tissues with large amounts of connective tissue (like breast, skin, or colon) or composed of multiple cores (TMAs) on Schott Nexterion Slide H - 3D Hydrogel Coated Slides (Schott North America, PN-1800434) to minimize risk of tissue detachment. Schott H slides may also be used if prior detachment has been observed with tissues of interest.
 - Schott Nexterion Slide H slides should be stored at -20°C and equilibrated for 30 min at room temperature prior to use.
- Tissue detachment may occur due to factors such as the quality of paraffin used during the tissue embedding process, the age of the tissue block, tissue section thickness, and the length of time used to infiltrate a tissue in paraffin.
- Carefully inspect the tissue block to gauge the extent of dehydration. Allow sufficient time in the ice bath to ensure proper hydration.
- Use a new, clean blade for sectioning each tissue type. Inspect the blade after every 20-25 sections and adjust to the blade areas that are not nicked or rough. Replace the blade after ~50 sections.
- Perform sectioning in a continuous motion to get a ribbon of sections. Sections should be separated while floating in the water bath. If floating multiple sections, monitor float time carefully.
- Ensure collected sections have the same thickness throughout experiments and replicates.
- Allow the section to float in the water bath until it is free of folds and wrinkles. Folds are associated with poor probe capture and can be identified via H&E staining, or by eye or under the microscope prior to staining. See [Troubleshooting on page 106](#) for more information.
- After section placement, gently flick the slide to remove excess water. A fan may be used to assist in drying. Leftover moisture under the tissue may result in tissue detachment.

Optional - Area of Interest Annotation

If a tissue section does not fit completely within the Visium HD Slide Capture Area, a smaller area of interest (AOI) should be defined.

The AOI should be:

- Small enough to fit inside a well in a Tissue Slide Cassette gasket. Tissue outside of the gasket will not be processed during the assay workflow.
- Centered within the appropriate Capture Area size on the Tissue Slide Stage on the Visium CytAssist instrument.

The following guidance applies if the Visium Alignment Aid will **not** be used:

Defining an AOI can occur after section placement by examining the tissue under a microscope or after H&E staining and imaging.

H&E Staining:

- Annotate the AOI using a marker on the back side of the tissue slide based on the assessment of tissue morphology from the H&E image. This annotation can serve as a reference for gasket placement when assembling the tissue slide in the Tissue Slide Cassette.
- Remove annotations with isopropanol or ethanol before loading the tissue slide onto the CytAssist instrument. Failure to remove annotations can lead to improper tissue detection, causing automatic tissue registration to fail. Should this occur, manual tissue registration on Loupe Browser will be required.
- When loading the tissue slide on the instrument, the pale eosin staining of the tissue area included within the gasket and the darker H&E staining of tissue areas outside the cassette will provide sufficient contrast to identify and align the correct tissue region on the CytAssist.

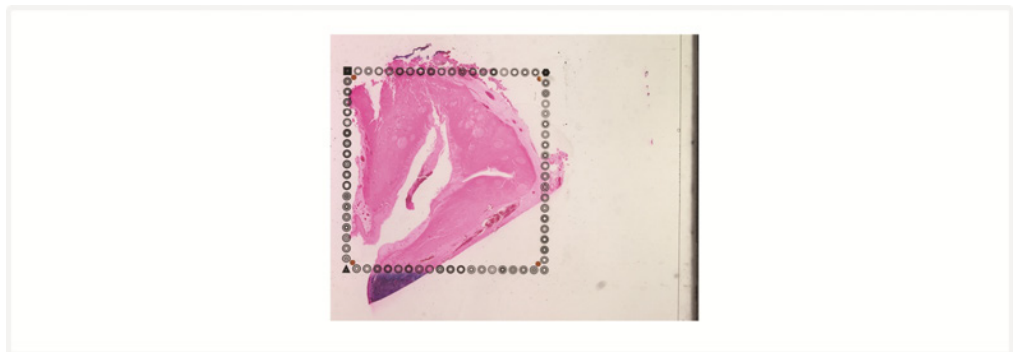

IF Staining:

- Before immunostaining, the tissue slide must be assembled in the Tissue Slide Cassette for decrosslinking. Since decrosslinking requires placing the gasket over the AOI prior to staining, 10x Genomics recommends using tissue morphology information from an adjacent H&E or IF stained section to annotate the back of the tissue slide. This annotation can serve as a reference for the gasket placement when assembling the tissue slide in the

Tissue Slide Cassette for the decrosslinking and immunostaining steps as well as help with reapplying the gasket after coverslip removal.

- Remove annotations with isopropanol or ethanol before loading the tissue slide onto the CytAssist instrument. Failure to remove annotations can lead to improper tissue detection, causing automatic tissue registration to fail. Should this occur, manual tissue registration on Loupe Browser will be required.
- When loading the slide on the instrument, the gasket imprint marks the boundary of the tissue area and can be used to align the AOI on the CytAssist.

If the Visium Alignment Aid will be used, the square window on the aid may be used to annotate an area of interest to assist in gasket assembly. In the User Guide, the same alignment aid is used to draw reference points that will be used to align the tissue slide onto the instrument. See [Visium CytAssist Alignment Aid on page 22](#) for more information.

Lint-free Laboratory Wipes

- All laboratory wipes used in the protocol must be 100% polyester and lint-free.
- Lens paper or non-lint free laboratory wipes are not suitable alternatives. See Visium HD Spatial Gene Expression Protocol Planner (CG000698) for tested part numbers.



Handling Tissue Slides

- When immersing slides in reagent, ensure all tissue sections are immersed.
- Maintain tissue slides in a low moisture environment such as a desiccator, avoid exposure to direct light, and keep at room temperature.
- Tissue slides that have been incubated at 42°C for 3 h and dried overnight at room temperature in a desiccator can be stored at room temperature or 4°C in a desiccator for up to 6 months. If storing at 4°C, allow tissue slides to come to room temperature prior to deparaffinization.
- Always wear gloves when handling slides.
- DO NOT touch the tissue sections on the slide.
- Minimize exposure of the slides to sources of particles and fibers.
- Keep the slide flat on the bench when adding reagents.
- Ensure that no absorbent surface is in contact with the reagents on the slide during incubation.

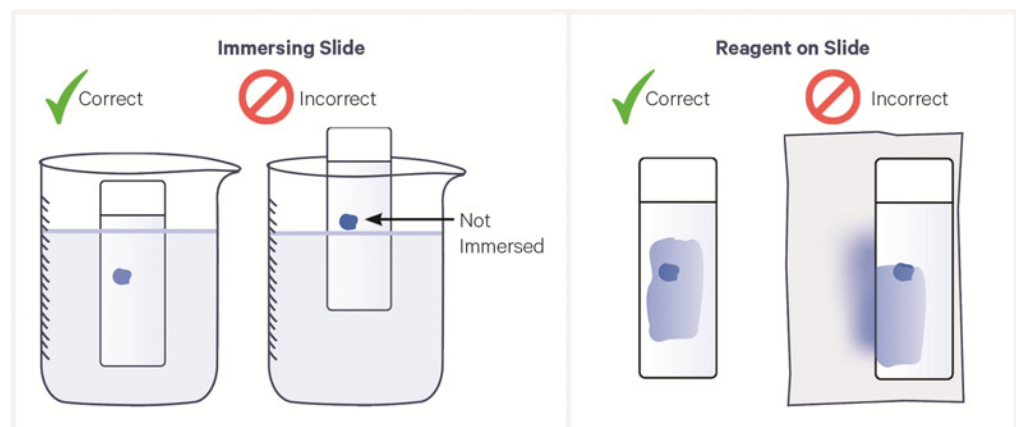

- DO NOT use a hydrophobic barrier (such as one applied by a PAP pen) on slides. These barriers may affect assay performance.
- Tissue slides may be annotated on the back of the slide to highlight an AOI. See [Optional - Area of Interest Annotation on page 13](#) for more information.
- When imaging, avoid pressing down on the coverslip to ensure easy removal after imaging.

Tissue Slide Incubation

Choose one of the following methods.

Incubation using a Section Dryer Oven:

- Place tissue slides in a slide drying rack on its side to prevent melted paraffin wax from disturbing adjacent tissue sections (if applicable).
- Close the lid when incubating tissue slides in the oven.

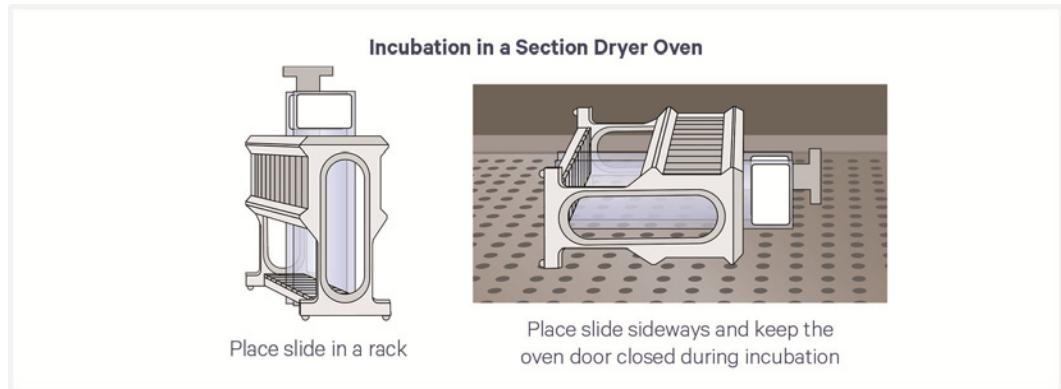

Incubation using a Thermal Cycler:

- Position a Low Profile Thermocycler Adapter on a thermal cycler that is set at the incubation temperature. Low Profile Thermocycler Adapter must come to temperature before placing tissue slide.
- Ensure that the Low Profile Thermocycler Adapter is in contact with the thermal cycler surface uniformly. Consult the Visium HD Spatial Gene Expression Protocol Planner (CG000698) for information on thermal cycler compatibility.
- Position tissue slides on the Low Profile Thermocycler Adapter with the side with tissue facing up.
- Ensure that the entire bottom surfaces of the tissue slides are in contact with the Low Profile Thermocycler Adapter.
- DO NOT close the thermal cycler lid when incubating tissue slides.
- Allow Low Profile Thermocycler Adapter to cool before removing from thermal cycler.

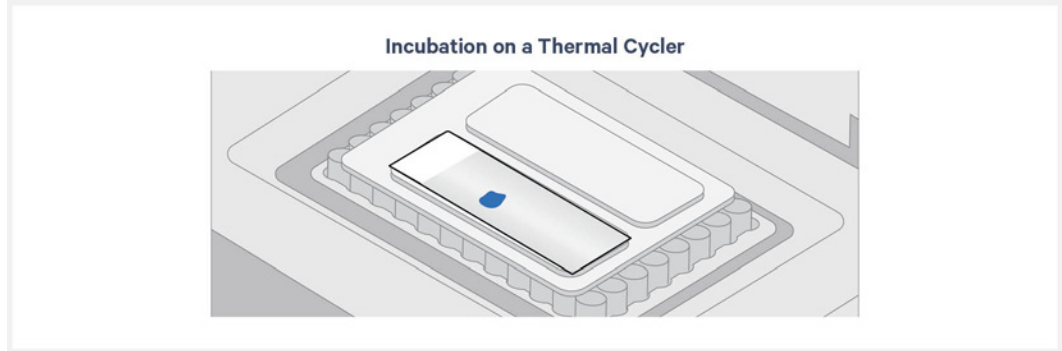

Cassette Incubation

Incubation using a Thermal Cycler:

- Position a Low Profile Thermocycler Adapter on a thermal cycler that is set at the incubation temperature. Low Profile Thermocycler Adapter must come to temperature before cassette placement.
- Ensure that the Low Profile Thermocycler Adapter is in contact with the thermal cycler surface uniformly. Consult the Visium HD Spatial Gene Expression Protocol Planner (CG000698) for information on thermal cycler compatibility.
- Ensure that the cassette sits flush with the raised portion of the Low Profile Thermocycler Adapter.
- Allow Low Profile Thermocycler Adapter to cool before removing from thermal cycler.

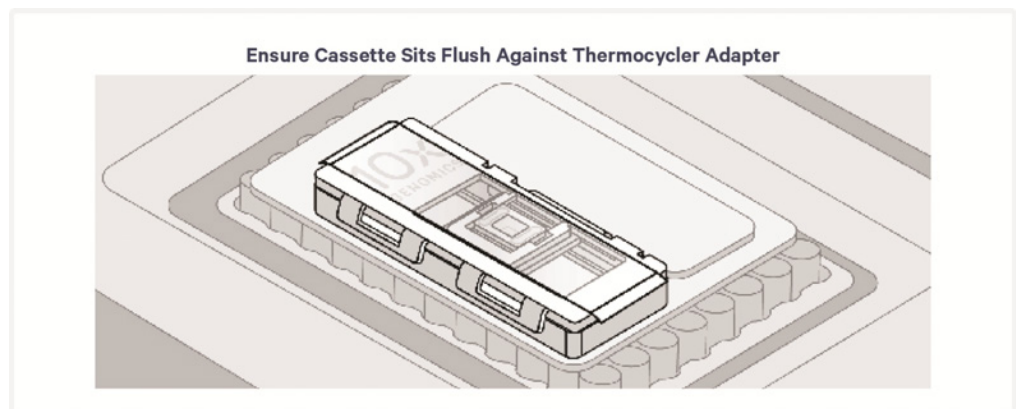

Reagent Addition to & Removal from Wells

Reagent Addition

- Assemble slide into the cassette flat on a clean work surface. See Cassette Assembly Quick Reference Card (CG000730).



Items from one cassette kit should not be used interchangeably with items from other cassette kits. To minimize the risk of mixing parts, always store all items in the original cassette kit box.

Illustrations show 6.5 mm cassettes; the information is applicable to 11 mm cassettes too.

- Dispense and remove reagents along the side of the wells without touching the slide surface, tissue sections (when applicable), and without introducing bubbles.
 - DO NOT forcefully insert pipette tip into well corners to avoid damaging the Visium HD Slide.
 - When processing two or more Visium Tissue Slide Cassettes, remove and add reagent from the first cassette before proceeding to the next cassette. Ensure tissue sections are always covered with reagent in between removal and addition steps to avoid drying out of tissue samples.
 - Unless indicated otherwise, when adding and removing reagent from a cassette, do so one well at a time. For example, remove reagent from A1 and add the next reagent to A1, before moving into onto D1, to avoid drying the well.
-  Always cover the Capture Area or tissue completely when adding reagents to the well. A gentle tap may help spread the reagent more evenly.

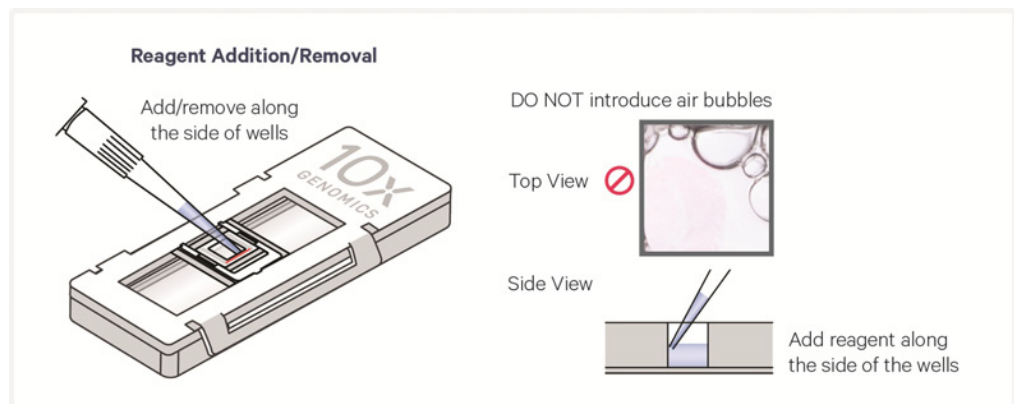

Reagent Removal from Wells

- Slightly tilt the cassette while removing the reagent. DO NOT completely tilt the cassette at a 90 degree angle to avoid liquid from entering other grooves within the gasket. See image below for proper technique.
- Place the pipette tip on the bottom edge of the wells.
- Remove reagents along the side of the wells without touching the tissue sections (when applicable) and without introducing bubbles.
- Remove all liquid from the wells in each step. To ensure complete removal, check the bottom of the well by tilting the cassette slightly. A meniscus at the bottom of the well will indicate the presence of liquid in the well. Repeat removal steps until no reagent remains.

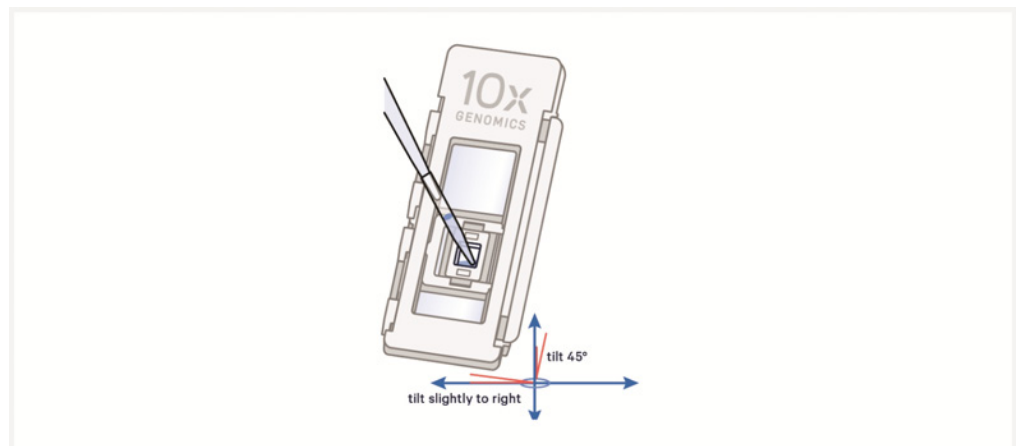

Visium Slide Seal Application & Removal

Application

- If applying a Visium Slide Seal to a Tissue Slide Cassette, the seal must be cut in half lengthwise. Cut the seal as shown in the image below. Six pre-cut seals per tissue slide are necessary for this assay.

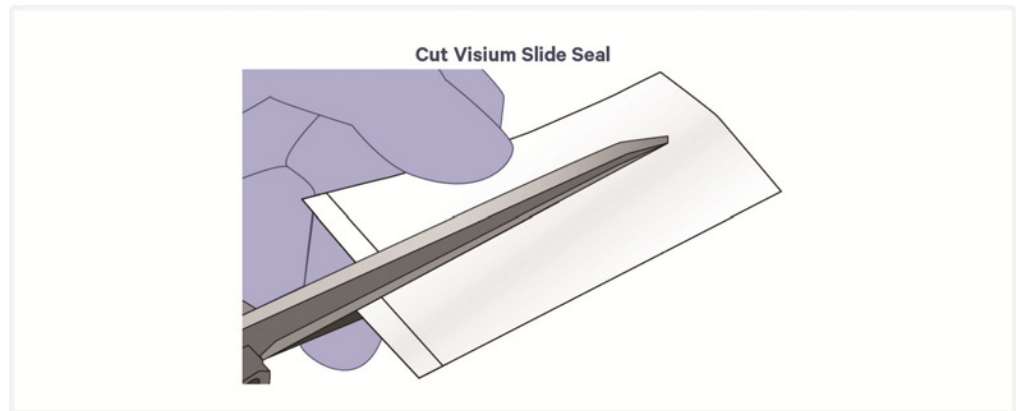

- Place the cassette flat on a clean work surface. Ensure surface of cassette is dry.
- Remove the back of the adhesive Visium Slide Seal.
- Align the Visium Slide Seal with the surface of the cassette and apply while firmly holding the cassette with one hand.
- Press on the Visium Slide Seal to ensure uniform adhesion.
- Use a fresh Visium Slide Seal when prompted during the protocol. Steps that do not require a new slide seal will specify that the slide seal should be pulled back and reapplied instead.

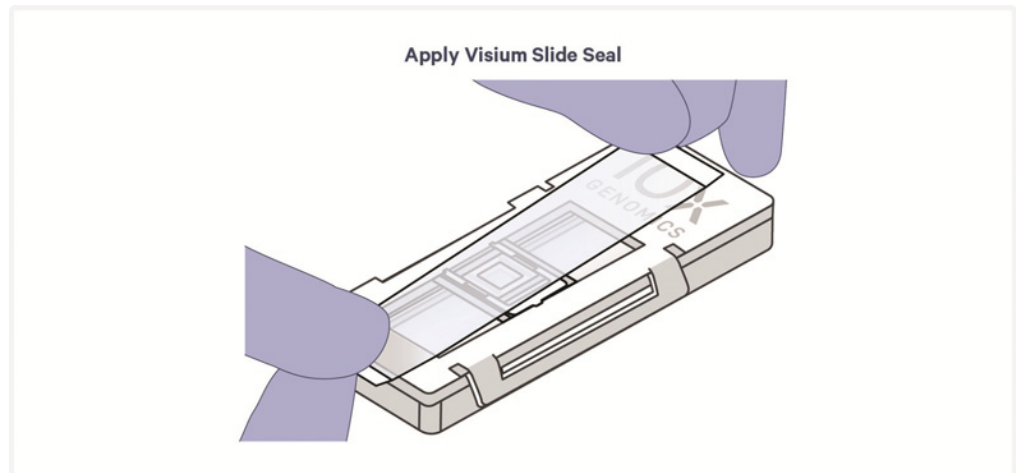

Removal

- Place the cassette flat on a clean work surface.
- Grasp a Visium Slide Seal corner. Carefully pull on the Visium Slide Seal up and across the cassette while firmly holding the cassette. Ensure that no liquid splashes out of the wells. Movement of the gasket during slide seal

removal could damage the tissue section.

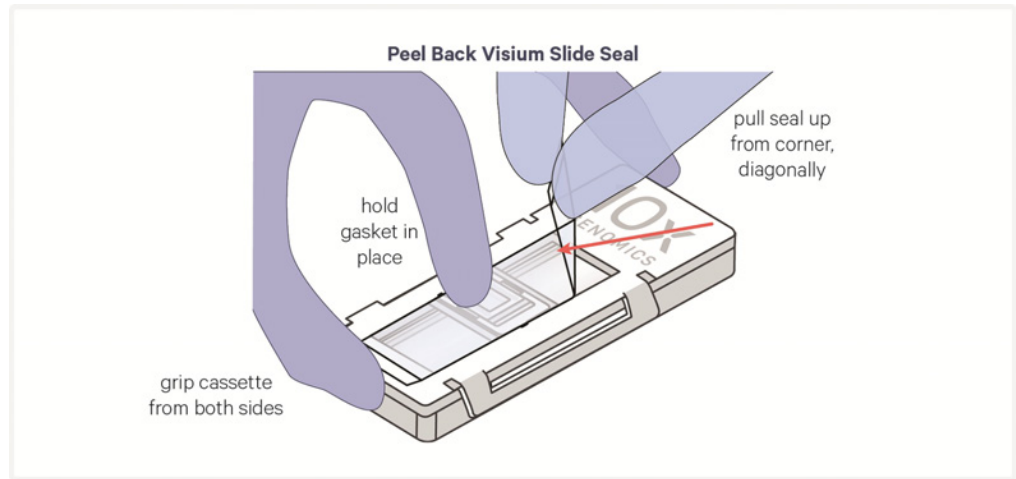

Visium CytAssist Alignment Aid

- The Visium CytAssist Alignment Aid (6.5 mm, PN-1000886 or 11 mm, PN-1000940); available for purchase separately) is an optional accessory used to draw annotations onto the back of the tissue slide to assist with alignment onto the Visium CytAssist instrument. It may also be used to annotate the square window to assist in gasket assembly.

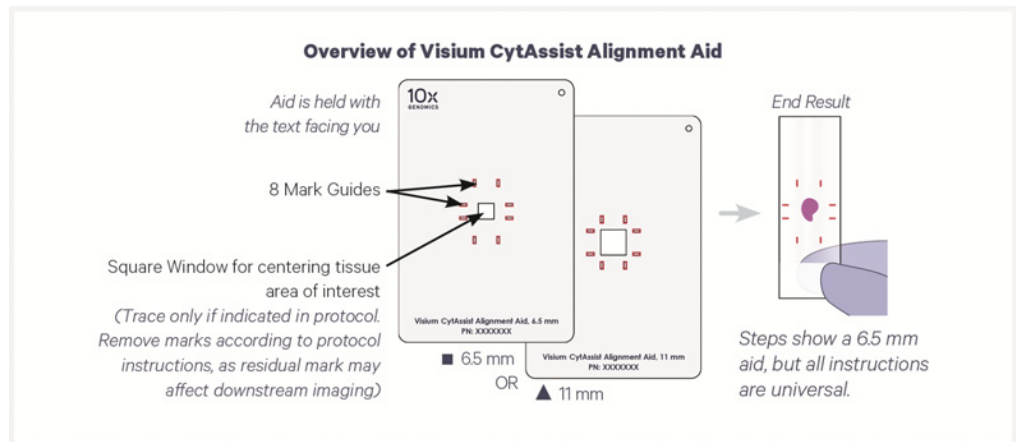

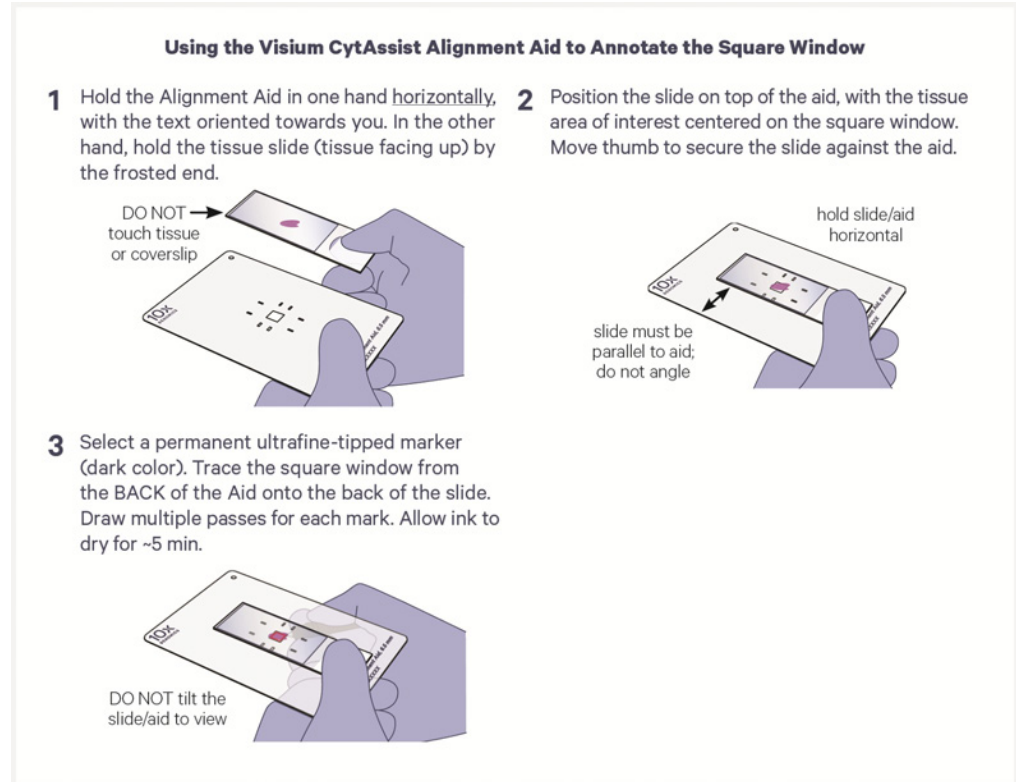

- Use aid when indicated in the protocol.
- The Alignment Aid has not been tested with Visium v2 protocols.
- The aid may be used to annotate the square window to assist in gasket placement during cassette assembly. This annotation must be removed after cassette assembly. Refer to the protocol for indications on when to remove the square window annotation.
- Marks drawn by tracing the "mark guides" shown in the image above on the back of the slide using the aid will not affect downstream CytAssist imaging.
- Before use:
 - Ensure back of tissue slide is dry.
 - If a coverslip is present, remove excess mounting medium by gently touching the slide to a lint-free laboratory wipe.
 - Clean aid with 70% isopropanol or 70% ethanol.
 - Obtain a permanent, ultrafine-tipped, dark-colored marker.
- During use:

- If a coverslip is present, do not move coverslip.
- Draw multiple passes for each mark.
- Allow ink to dry for ~5 min.
- Once marks are drawn, avoid wiping the back of the slide vigorously to prevent mark removal. Instead, tap the back of the slide onto a lint-free laboratory wipe to remove excess moisture.

1. Archived Slide Processing

Overview

This chapter provides guidance on processing archived H&E slides. Archived slides are slides with FFPE tissue sections and a hardset mounted coverslip. These slides are in contrast to slides with freshly placed FFPE sections, as described in [Section Placement on page 50](#). Archived slides should have been stained, imaged, and stored at room temperature or 4°C. Over time, archived slides may experience RNA degradation; thus, freshly placed FFPE tissue sections are preferred for the Visium HD assay. Only archived slides that have been H&E stained have been tested with the Visium HD workflow.

RNA quality assessment should be performed on archived slides derived from the same tissue block as the slide that will be used for the full Visium HD assay. If this is not possible, an unimportant area of the section for processing can be scraped to assess RNA quality.

Before hardset coverslip removal, verify that images of archived slides meet the specifications required for analysis as specified in Visium HD Spatial Applications Imaging Guidelines Technical Note (CG000688). If images are absent or incompatible, before hardset coverslip removal, image the archived slide according to imaging guidelines.

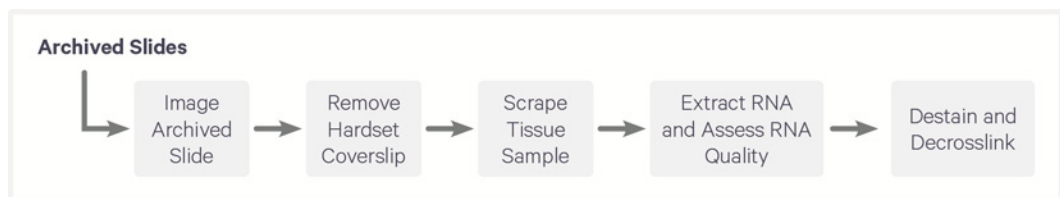

Remove Hardset Coverslip

Archived slides are incubated in xylene followed by rapid freezing to remove coverslips without damaging tissue sections. Slides are then immerse in an additional xylene gradient (to remove excess mountant), an ethanol gradient, and a final water wash.

Scrape Tissue Sample

Once hardset coverslip is removed, a small portion from a proximal section or an unimportant area of tissue from the section of interest is scraped to assess RNA quality.

Assess RNA Quality

RNA quality is assessed by scraping off a portion of the tissue, extracting RNA, and calculating the DV200 score.

Mean RNA fragment size is a reliable determinant of RNA quality. This requires a measurement of the percentage of total RNA fragments >200 nucleotides (DV200) for RNA quality assessment upstream of library preparation. For more information on DV200, see Appendix 1: [DV200 Performance and Recommendations on page 113](#). 10x Genomics recommends that the tissues used with the Visium HD Spatial Gene Expression should have a DV200 of > 30%.

Before starting RNA extraction, apply RNaseZap to a paper towel and wipe work surface, centrifuge rotor and shafts of the pipettes. Rinse with RNase-free water and then wipe dry. The electrodes of the Bioanalyzer can also be cleaned with RNaseZap by following Agilent decontamination procedure.

Destaining and Decrosslinking

After RNA quality assessment, H&E-stained slides have their hematoxylin removed via destaining. After destaining, tissue sections are decrosslinked to ensure that RNA molecules are accessible.

1.0 Preparation

Consult the Visium HD Spatial Applications Protocol Planner (CG000698) for a list of third-party items.



For Coverslip Removal and RNA Assessment

Items	Preparation & Handling	
Prepare fresh weekly. Process two slides per jar. Process no more than 20 slides before replacing reagents. Alternatively, use a slide staining dish. Adjust volumes of deparaffinization solutions and water accordingly and ensure volume fully covers tissue.		
<input type="checkbox"/>	Xylene	Label two Coplin jars or staining dishes as Xylene Jar 1 and 2. Dispense 30 ml xylene in each.
<input type="checkbox"/>	100% Ethanol	Label two Coplin jars or staining dishes as 100% Ethanol Jar 1 and 2. Dispense 30 ml 100% ethanol in each.
<input type="checkbox"/>	96% Ethanol	Label two Coplin jars or staining dishes as 96% Ethanol Jar 1 and 2. Dispense 30 ml 96% ethanol in each.
<input type="checkbox"/>	70% Ethanol	Label one Coplin jar or staining dish as 70% Ethanol Jar. Dispense 30 ml 70% ethanol.
<input type="checkbox"/>	Nuclease-free water	Label one Coplin jar or staining dish as Water Jar. Dispense 30 ml nuclease-free water.
Obtain		
<input type="checkbox"/>	100% Ethanol	-
<input type="checkbox"/>	1X PBS	Prepare 1X PBS from 10X stock.
<input type="checkbox"/>	Xylene	-
<input type="checkbox"/>	Metal Block	-
<input type="checkbox"/>	New Razor Blade	-
<input type="checkbox"/>	Dry Ice	-
<input type="checkbox"/>	0.2 ml 8-tube Strip	-
<input type="checkbox"/>	RNeasy FFPE Kit	RNeasy MinElute Spin Column, Buffer PKD, Proteinase K, DNase Booster Buffer, DNase I Solution, RBC Buffer, and RPE Buffer are contained in this kit.

For Destaining

Items	10x PN	Preparation & Handling	Storage	
Prepare fresh before use				
<input type="checkbox"/>	0.1 N HCl	-	Prepare 0.1 N HCl using nuclease-free water.	Ambient
<input type="checkbox"/>	TE Buffer (10 mM Tris and 1 mM EDTA), pH 8.0	-	-	Ambient
<input type="checkbox"/>	1X PBS	-	Prepare 2 ml of 1X PBS. This volume of 1X PBS is sufficient for both destaining and decrosslinking. If using 10X PBS stock, prepare 2 ml 1X PBS from 10X stock using nuclease-free water.	

For Decrosslinking

Items	10x PN	Preparation & Handling	Storage	
Heat to 37°C				
<input type="checkbox"/>	 Decrosslinking Buffer B	2001094	Pre-heat thermomixer or water bath to 37°C. Thaw in a thermomixer (300 rpm with shaking) or water bath for 30 min at 37°C during Destaining.	-20°C
Equilibrate to room temperature				
<input type="checkbox"/>	 Perm Enzyme B	3000553	Remove from -20°C shortly before use. Maintain at room temperature. Pipette mix, centrifuge briefly. DO NOT vortex.	-20°C
<input type="checkbox"/>	 Decrosslinking Buffer B	2001094	After heating to 37°C as indicated above, cool to room temperature for 5 min. Vortex for 30 sec and centrifuge briefly.	-20°C
Obtain				
<input type="checkbox"/>	Nuclease-free Water	-	-	Ambient
<input type="checkbox"/>	1X PBS	-	Prepare 1 ml 1X PBS from 10X stock.	Ambient
<input type="checkbox"/>	8M Urea	-	-	Ambient

1.1 Hardset Coverslip Removal and Slide Processing

Xylene incubation steps should be performed in a fume hood. Either Coplin jars or staining dishes may be used. If archived slides have been H&E stained, image the archived slide according to guidelines described in the Visium HD Spatial Applications Imaging Guidelines Technical Note (CG000688) and ensure they are compatible with the Space Ranger analysis pipeline prior to hardset coverslip removal.

- a. Cool a metal block on dry ice for **5–10 min**.
- b. Gently immerse archived slide in Xylene Jar 1. Secure the jar cap to prevent xylene loss.
- c. Incubate for **5 min**.
- d. Remove excess xylene from archived slide with a lint-free laboratory wipe.
- e. Place on pre-cooled metal block with the coverslipped tissue sections facing down.
- f. Wait **1 min**.

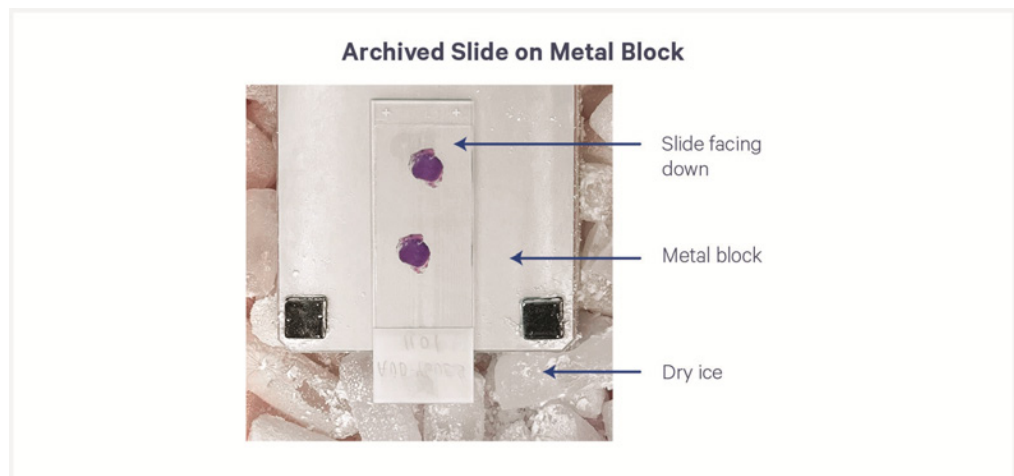

- g. Insert a clean blade a short distance between coverslip and archived slide on the shorter edge of the archived slide (see image below).



Work slowly in small steps, keeping the archived slide on the cold metal block in between steps. Avoid touching tissue with the blade. Exercise caution, as the blade is sharp.



- h.** Gently immerse slides 2x in Xylene Jar 1, then immerse and incubate for **10 min.** Secure jar cap to prevent xylene loss.
- i.** Gently immerse slides 2x in Xylene Jar 2, then immerse and incubate for **10 min.** Secure jar cap to prevent xylene loss.
- j.** Gently immerse slides 2x in 100% Ethanol Jar 1, then immerse and incubate for **3 min.**
- k.** Gently immerse slides 2x in 100% Ethanol Jar 2, then immerse and incubate for **3 min.**
- l.** Gently immerse slides 2x in 96% Ethanol Jar 1, then immerse and incubate for **3 min.**
- m.** Gently immerse slides 2x in 96% Ethanol Jar 2, then immerse and incubate for **3 min.**
- n.** Gently immerse slides 2x in 70% Ethanol Jar, then immerse and incubate for **3 min.**
- o.** Gently immerse slides 2x in Water Jar, then immerse and incubate for **20 sec.**
- p.** Remove excess water from archived slide carefully with a lint-free laboratory wipe. Do not touch tissue.
- q.** If not performing RNA quality assessment, proceed directly to [Destaining on page 34](#) or store in a sealed slide mailer in a desiccator kept in the dark at **4°C** for up to **one week**.

If performing RNA Quality Assessment:

- Select a small portion of the section that can be scraped for RNA quality assessment. Sections for RNA quality assessment should have a minimum

size of 2 x 2 mm and minimum thickness of 5 μm . Practice scraping sections from test tissues.

- Using a clean blade, scrape the small portion for RNA quality assessment in one motion, resulting in one curl.



- Lift the curl using the blade, and use a clean pipette tip to transfer curl to one RNase-free 0.2-ml tube in a tube strip on ice. Store at **-80°C** for long-term storage or proceed immediately to RNA Extraction. If processing multiple archived slides, curls can be kept in tube strips on ice until ready for RNA extraction.
-  • The remaining section on the archived slide may be used for the Visium HD workflow or stored in a sealed slide mailer in a desiccator kept in the dark at **4°C** for up to **one week** to allow time for RNA evaluation.

1.2 RNA Extraction

- a. Prepare the thermal cycler with the following incubation protocol and start the program.

Lid Temperature	Reaction Volume	Run Time
80°C	160 µl	30 min
Step	Temperature	Time hh:mm:ss
Pre-equilibrate	56°C	Hold
Incubation 1	56°C	00:15:00
Incubation 2	80°C	00:15:00

- b. Add **150 µl** of Buffer PKD to sample tube and pipette mix.
- c. Add **10 µl** of Proteinase K to sample tube and pipette mix.
- d. Add sample tube to thermal cycler and skip Pre-equilibrate step.
- e. Pipette mix every **5 min** (pipette set to 120 µl) during Incubation 1 and 2 steps. Pipette mix without removing tube from block to prevent burns. Pipette mix gently to avoid generating bubbles.
- f. Incubate a 2-ml microcentrifuge tube on ice for **3 min**.
- g. Transfer sample to the pre-cooled 2-ml microcentrifuge tube after Incubation 2.
- h. Add **16 µl** of DNase Booster Buffer to tube.
- i. Add **10 µl** of DNase I Solution to tube. Pipette mix.
- j. Incubate at room temperature for **15 min**.
- k. Add **320 µl** of RBC Buffer to tube and pipette mix.
- l. Add **720 µl** of 100% Ethanol to tube and pipette mix.
- m. Transfer sample to RNeasy MinElute column. Do not allow sample to overflow in the column.
- n. Centrifuge column for **15 sec** at **8,000 rcf**.
- o. Repeat steps m-n until all sample has passed through the column.
- p. Add **500 µl** of RPE Buffer to column.
- q. Centrifuge column for **2 min** at **8,000 rcf**.
- r. Transfer column to a new 2-ml microcentrifuge tube.

- s. Centrifuge column for **5 min** at **maximum speed** with column lid open.
- t. Transfer column to a new 2-ml microcentrifuge tube.
- u. Add **12 µl** of nuclease-free water to column.
- v. Centrifuge column for **1 min** at maximum speed.
- w. Using a Nanodrop or Qubit Fluorometer, measure RNA concentration to determine the appropriate dilution for DV200 evaluation using the RNA 6000 Pico Kit or TapeStation High Sensitivity Kit.
- x. Store purified RNA at **-80°C** for **long-term** storage or immediately proceed to DV200 evaluation using either the Agilent RNA 6000 Pico Kit or TapeStation High Sensitivity Kit. Follow manufacturer's instructions (Agilent) for DV200 evaluation.
Tissues used with the Visium HD Spatial Gene Expression assay should have a DV200 of > 30%. RNA outside of the recommended concentration may lead to inaccurate DV200 evaluation. For more information on DV200, see [DV200 Performance and Recommendations on page 113](#).

After DV200 evaluation, proceed with [Destaining on the next page](#).

1.3 Destaining

- a. Place a Low Profile Thermocycler Adapter in the thermal cycler. Prepare the thermal cycler with the following incubation protocol and start the program.

Lid Temperature	Reaction Volume	Run Time
42°C (lid may be set to lowest temperature if instrument does not enable 42°C)	100 µl	15 min

Step	Temperature	Time hh:mm:ss
Pre-equilibrate	42°C	Hold
Destaining	42°C	00:15:00
Hold	22°C	Hold

- b. Place the slide in a Tissue Slide Cassette.
See Visium Cassette S3 Quick Reference Card (CG000730) for assembly instructions. Practice assembly with a blank slide.
- c. Add **■150 µl** or **▲300 µl** 0.1 N HCl along the side of the wells to uniformly cover the tissue sections, without introducing bubbles. Tap cassette gently to ensure uniform coverage.
- d. Remove HCl from the wells.
- e. Add **■100 µl** or **▲200 µl** 0.1 N HCl along the side of the wells to uniformly cover the tissue sections, without introducing bubbles. Tap cassette gently to ensure uniform coverage.
- f. Apply pre-cut slide seal on cassette and place the cassette on the Low Profile Thermocycler Adapter at **42°C**.
- g. Close the thermal cycler lid. Skip Pre-equilibrate step to initiate Destaining.
- h. Remove the cassette from the Low Profile Thermocycler Adapter and place on a flat, clean work surface. Some color remaining in the tissue after thermal cycler incubation is normal.

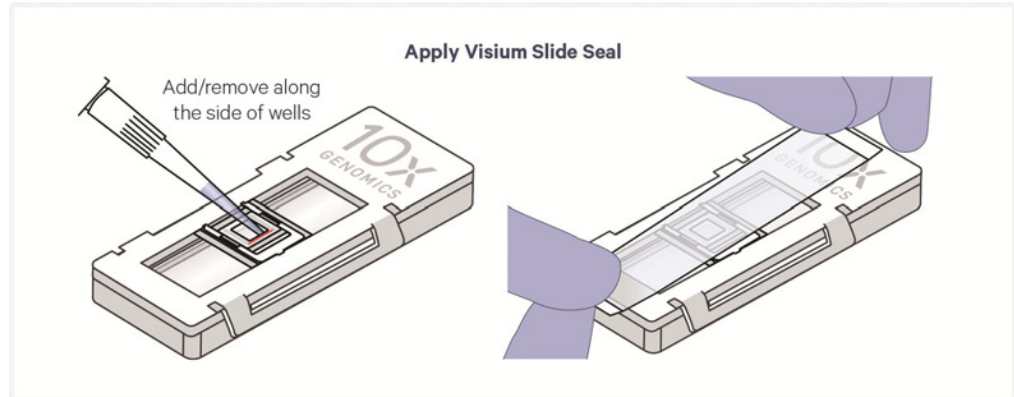

- i. Remove slide seal. and using a pipette, remove all the HCl from the well corners.

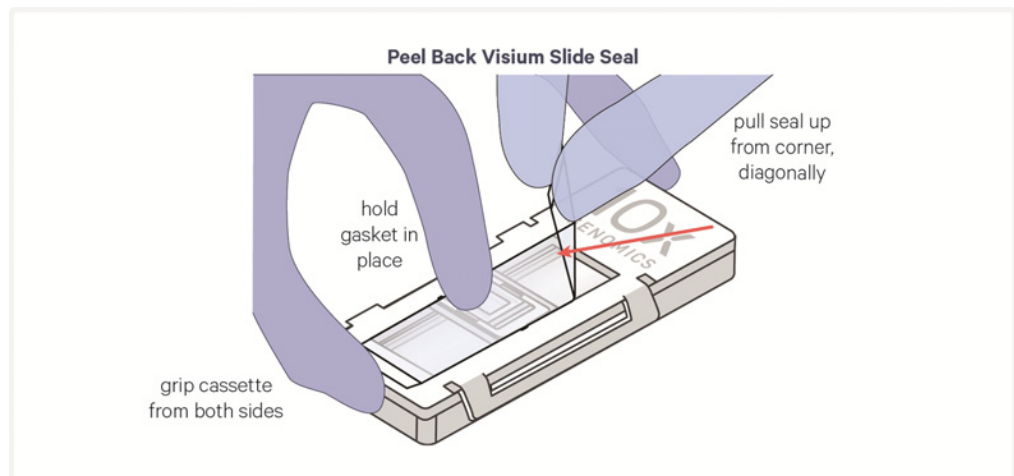

Three TE Buffer washes:

- j. **Wash 1:** Add **150 μ l** or **300 μ l** TE Buffer (pH 8.0) along the side of the wells. Incubate for **5 min** at **room temperature**. Remove TE Buffer from the wells.
- k. **Wash 2:** Add **150 μ l** or **300 μ l** TE Buffer (pH 8.0) along the side of the wells. Incubate for **5 min** at **room temperature**. Remove TE Buffer from the wells.
- l. **Wash 3:** Add **150 μ l** or **300 μ l** TE Buffer (pH 8.0) along the side of the wells. Incubate for **5 min** at **room temperature**. Remove TE Buffer from the wells.
- m. Add **100 μ l** or **200 μ l** 1X PBS along the side of the wells.
- n. Proceed directly to Decrosslinking.

1.4 Decrosslinking

■ denotes volumes for 6.5 mm gaskets and ▲ denotes volumes for 11 mm gaskets.



Ensure Decrosslinking Buffer B has been prepared according to [Preparation on page 27](#).

- a. Prepare the thermal cycler with the following incubation protocol and start the program.

Lid Temperature	Reaction Volume	Run Time
80°C	100 µl	40 min
Step	Temperature	Time hh:mm:ss
Hold	22°C	Hold
Decrosslinking	80°C	00:30:00
Re-equilibrate	22°C	00:10:00
Hold	22°C	Hold



- b. Prepare Diluted Perm Enzyme B according to the table below. Add reagents in the order listed. Mix thoroughly with a P20 pipette set to 17 µl. Maintain at room temperature.

Diluted Perm Enzyme B	Stock	Final	10x PN	Total Amount (µl)
1X PBS	-	-	-	16.8
 Perm Enzyme B (Maintain at room temperature. Pipette mix, centrifuge briefly. DO NOT vortex).	-	-	3000553	3.2
Total	-	-	-	20.0

- c. Prepare Decrosslinking Mix according to the appropriate table below. Add reagents in the order listed. Pipette mix thoroughly. Centrifuge briefly. Maintain at room temperature.

6.5
mm

6.5 mm Gaskets							
Decrosslinking Mix 1 slide = 1 Tissue Slide	Stock	Final	10x PN	1 slide (µl)	2 slides + 10% (µl)	4 slides + 10% (µl)	
Decrosslinking Buffer B	-	-	2001094	92.50	203.50	407.00	
Urea	8 M	0.5 M	-	6.25	13.75	27.50	
Diluted Perm Enzyme B	-	-	-	1.25	2.75	5.50	
Total	-	-	-	100.00	220.00	440.00	

11
mm

11 mm Gaskets							
Decrosslinking Mix 1 slide = 1 Tissue Slide	Stock	Final	10x PN	1 slide (µl)	2 slides + 10% (µl)	4 slides + 10% (µl)	
Decrosslinking Buffer B	-	-	2001094	185.0	407.0	814.0	
Urea	8 M	0.5 M	-	12.5	27.5	55.0	
Diluted Perm Enzyme B	-	-	-	2.5	5.5	11.0	
Total	-	-	-	200.0	440.0	880.0	

- d. Remove 1X PBS from the wells.
- e. Add ■ **100 µl** or ▲ **200 µl** Decrosslinking Mix along the side of the wells
- f. Apply a new pre-cut slide seal on the cassette and place the cassette on the Low Profile Thermocycler Adapter.
- g. Close and tighten thermal cycler lid. Skip Pre-equilibrate step and initiate Decrosslinking.
- h. Proceed **immediately** to Visium HD Spatial Gene Expression Reagent Kits 2.0 User Guide (CG001679).

2. Tissue Handling, FFPE Tissue Sectioning, Section Placement, and Quality Assessment

Overview

This chapter provides guidance on tissue handling, tissue fixation, tissue sectioning, section placement, and quality assessment.

Tissue quality is an important factor in Visium assay performance. Preparing high-quality human tissue blocks can be more challenging than mouse tissues due to less control over ischemia and Post Mortem Interval (PMI). For example, human brain samples can be challenging for these reasons. For specific guidance on processing human brain samples, consult the Tested Tissues List on the 10x Genomics support website.

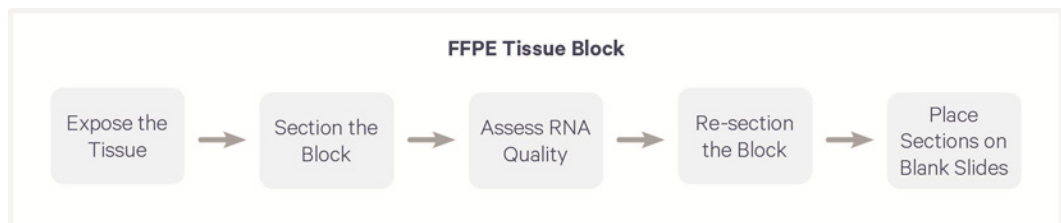

Tissue Handling

Prior to fixation and embedding, tissues should be handled according to the following guidelines to maximize RNA quality and prevent degradation.

- **Gentle Handling** - Handle tissue gently to avoid mechanical stress, which may damage tissue structure. Processes that introduce mechanical stress include ischemia, coagulative necrosis from electrocautery, and hemorrhages from surgical trauma.

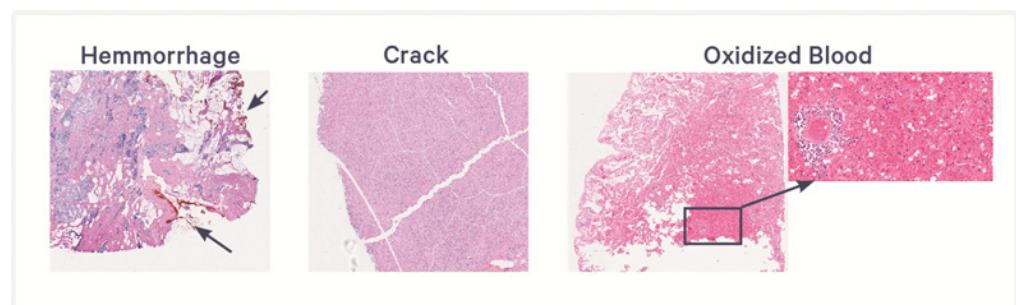

In the image below, necrotic regions within the green lines show nuclear condensation (pyknosis) and nuclear fragmentation (karyorrhexis). These regions typically have poor RNA quality. The surrounding regions have normal-appearing nuclei.

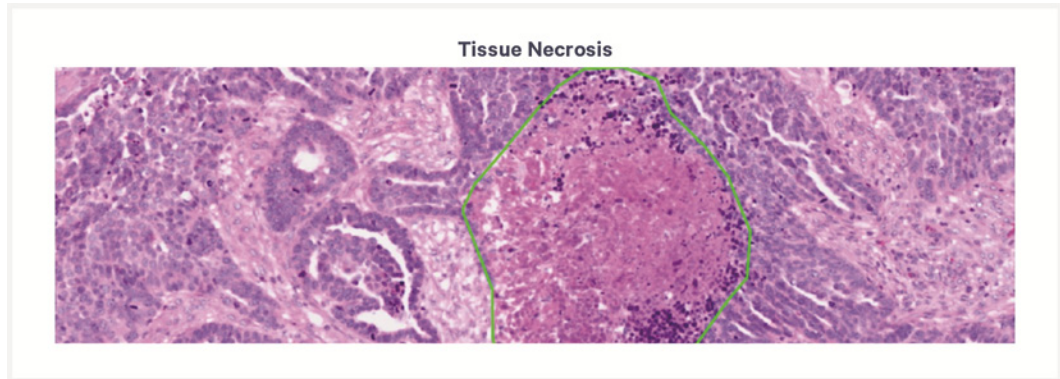

Minimizing Ischemia/Post Mortem Interval (PMI) and Fixation Timing

- Prolonged ischemia and PMI can negatively affect tissue quality. If processing delays occur, keep tissues in a cold isotonic solution and avoid exceeding four hours between tissue resection and fixation, though this time may be tissue dependent. Tissues should be fixed immediately after resection. Delayed tissue fixation may lead to autolysis, degrading tissue, and negatively impacting results.
- In the following example H&E images, considerable degradation of tissue quality or autolysis occurs as the time from fresh mouse brain tissue collection to fixation increases. In the zoomed in image, the dentate gyrus region shows considerable deterioration of nuclear architecture (signs of nuclear condensation and nuclear fragmentation) with increasing delays to fix the tissue

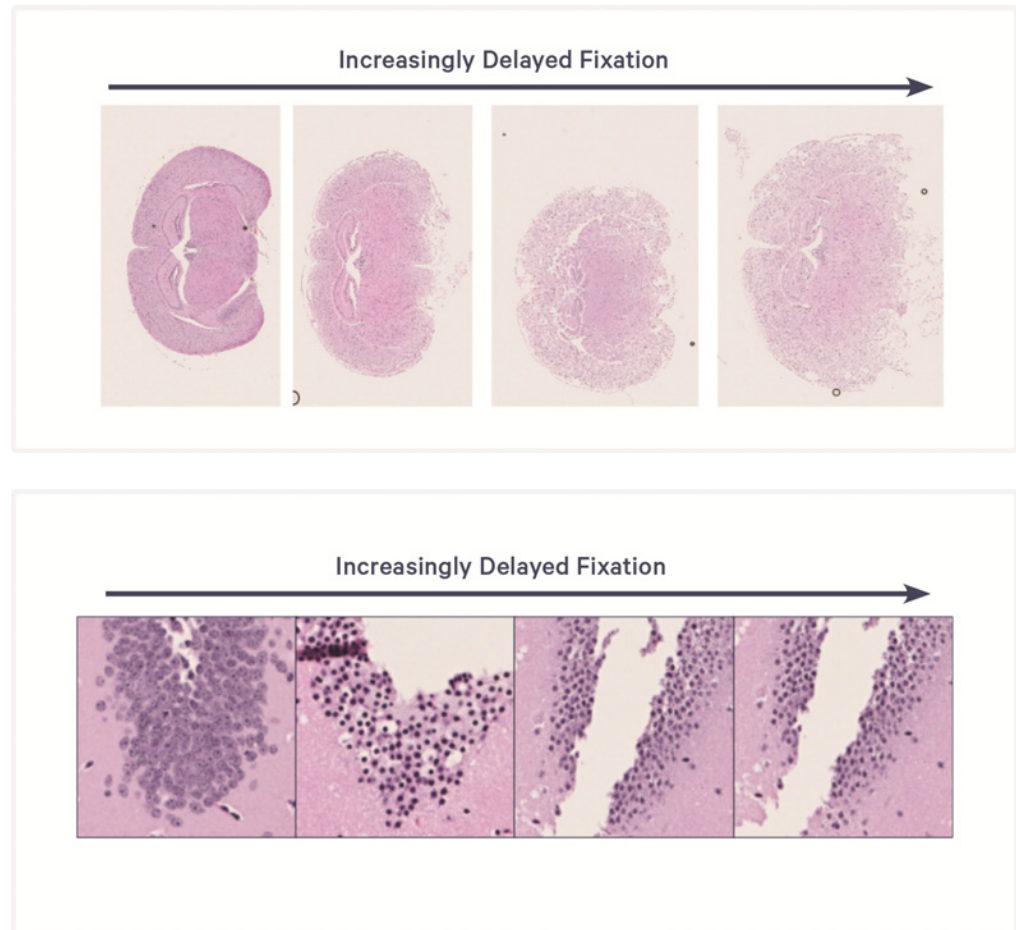

Fresh Tissue Storage

Store tissues in a cool and moist environment to prevent tissue drying and degradation. Tissues can be kept in an isotonic solution (e.g. RNase-free PBS) if tissue cannot be fixed immediately. Keeping tissues in isotonic solutions is not suitable for long-term storage. Avoid exceeding four hours. 10x Genomics cannot provide specific guidance on isotonic solutions or RNA preservation products.

Tissue Fixation

Improper sample fixation (over or underfixation) can negatively impact assay performance.

- Underfixation can lead to the continued activity of certain enzymes postmortem or postoperation, which can contribute to the degradation of proteins, nucleic acids, and lipids. RNA may also not be properly preserved

in underfixed tissues. Lastly, underfixation can lead to the presence of artifacts in the tissue such as irregular chromatin patterns, overstained cytoplasm (eosin), and common autolysis artifacts such as separation of epithelium from connective tissue.

- Overfixation may lead to a loss of structural integrity of certain molecular features, lipid oxidation, excessive crosslinking, and decreased antigenicity. Additionally, overfixation may make sectioning more challenging due to tissue hardening. Overfixation can lead to tissue artifacts such as irregularly shaped/smaller cells or hyperchromatic nuclei staining.

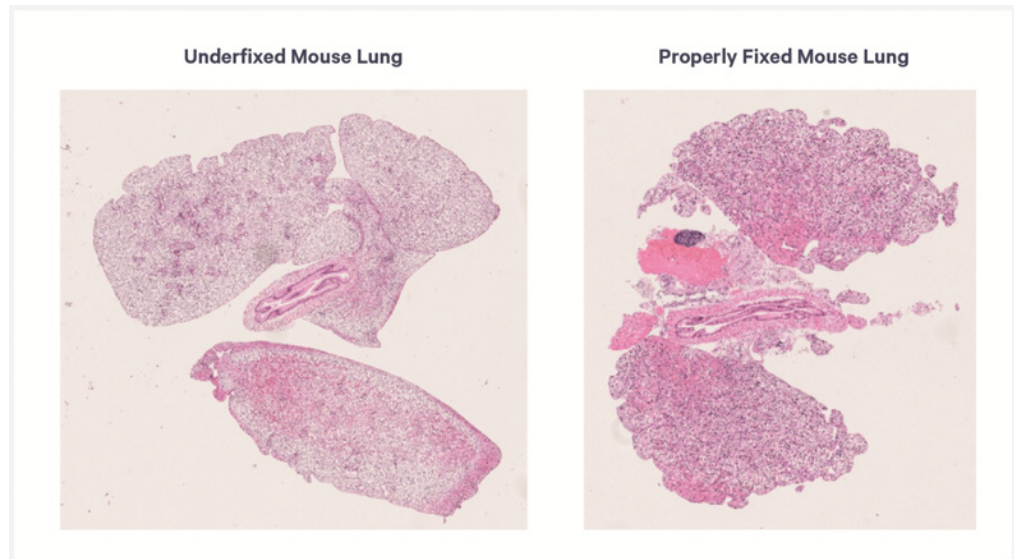

To ensure proper tissue fixation, consider the following.

- Tissue size - The thickness of the tissue significantly affects fixative penetration. Freshly collected tissues should be trimmed with a scalpel to ensure that the thickness of the tissue piece is not larger than a standard tissue processing cassette used for preparation of FFPE blocks. Typically, a tissue thickness of 5–10 mm would be accommodated by most standard tissue cassettes and ensure proper penetration of fixative.
- Fixative and fixative to tissue ratio - The use of 10% Neutral Buffered Formalin (NBF) or 4% paraformaldehyde (PFA) at a fixative to tissue ratio of 20:1 is recommended for optimal performance.
- Fixation time and temperature - Fixation should be carried out at **4°C** for **~16–24 h** to ensure proper fixative penetration. Fixation time may be tissue-dependent and require optimization. Ensure tissue is completely submerged and introduce light agitation.

Optimizing Embedding

Tissues should be embedded according to the following guidelines to maximize RNA quality and prevent degradation. These steps generate a formalin fixed & paraffin embedded block that is ready for sectioning.

Dehydration

After fixation, tissues are dehydrated in an ethanol series to displace any water remaining in the tissue. Inadequate dehydration may result in poor preservation of tissue structure and damage during sectioning.

Clearing

Tissues are "cleared" using a solvent to remove any remaining ethanol. Inadequate clearing may lead to poor wax infiltration, which can result in hard and brittle blocks that are difficult to section.

Infiltration

After clearing, wax is applied to the tissue and allowed to infiltrate. Inadequate wax infiltration may result in holes or gaps in the final block, which may lead to sectioning difficulties. Typically, wax is melted at 60–62°C prior to adding to the tissue. It is then allowed to cool to 20°C. Avoid excessive heat and check temperatures regularly during embedding. Use a high-quality wax with a low melting temperature.

Embedding

Finally, tissues are embedded in paraffin. Record orientation of the tissue during paraffin embedding to ensure proper spatiality for downstream region selection.

Additional Tissue Preparation Tips and Best Practices

- Regularly replace reagents used during the fixation and embedding process.
- DO NOT store or leave sample in fixative for an extended period of time, which will lead to overfixation.
- Proceed immediately from fixation to dehydration, clearing, and embedding. If proceeding to dehydration immediately is not possible, transfer tissue from fixative to 70% ethanol at 4°C for up to 1 week. If storage in 70% ethanol must exceed 1 week, replace the 70% ethanol weekly. Depending on the tissue type and length of storage, tissue quality may be impacted.
- Store FFPE blocks properly to maintain integrity. Avoid exposure to high temperatures or humidity. For optimal storage, store at 4°C.

Exposing the Tissue

A FFPE tissue block is placed in a microtome and cut to expose the tissue or face the block.

Sectioning for RNA Quality Assessment

A microtome sections the tissue block to generate sections for blank slides. If assessing RNA quality, generate 2 adjacent 5 μm sections and use one for quality assessment and the other for the assay. Refer to [Tips & Best Practices on page 10](#) for FFPE block sectioning and handling.

RNA Quality Assessment

Assess tissue block RNA quality by extracting RNA and using it to calculate the DV200 of freshly collected tissue sections. RNA quality assessment should be done before placing the tissue sections on blank slides. Use sections from the same tissue block that will produce sections for the main assay. If extra sections are available, placing them on slides for Optional Tissue Morphology Assessment is recommended. Additionally, estimating RNA quantity per cell may be performed, as this method may reveal samples not suitable for the assay that otherwise have promising DV200 and morphology results. Use the decision tree below to determine what quality assessment protocols should be followed.

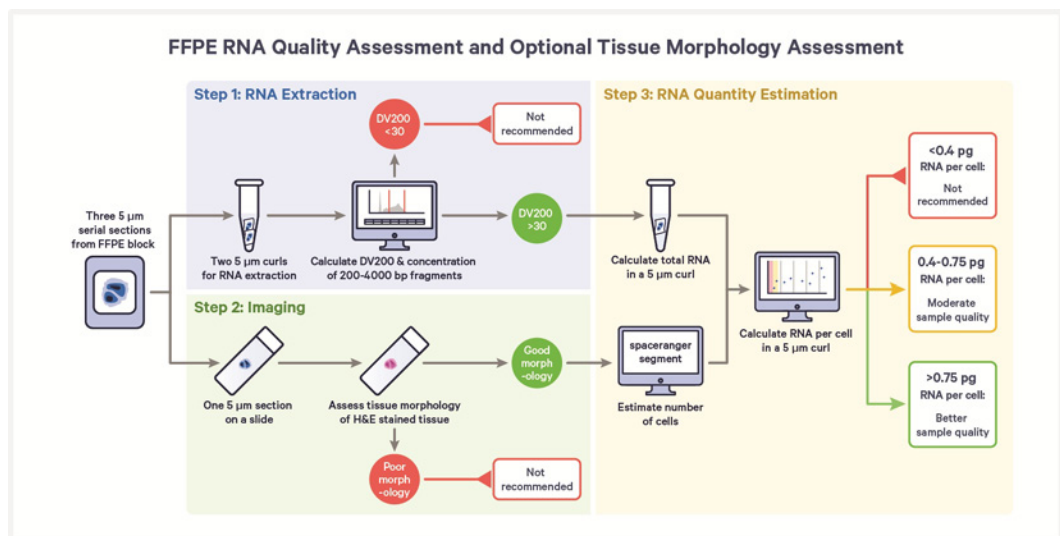

Re-sectioning

A microtome sections the tissue block to generate sections for blank slides.

Section Placement

Sections are collected in a water bath and are allowed to float on the water surface until they are flat and free from wrinkles and folds. The optimal floating time depends upon the specific tissue type and should be empirically determined when working with new tissue types. Expanded sections are then placed on blank slides.

Practice section placement using a nonexperimental block before proceeding with tissue slides for the Visium HD Spatial Gene Expression workflow. Each tissue slide must only be used for one CytAssist instrument run. DO NOT rerun tissue slides as this could affect assay performance.

Optional Tissue Morphology Assessment

Assessment of tissue morphology prior to performing the Visium HD assay is recommended, but not mandatory. This assessment is composed of DAPI and H&E staining. After staining, tissues are assessed to determine suitability for the Visium HD assay.

DAPI and H&E may be performed on the same tissue section or on serial sections. If extra tissue sections are not available to perform this assessment, H&E or IF images generated later in this handbook may be evaluated to gain additional insights on sample quality.

Estimation of DV200 scores as well as the morphological assessments based on H&E and/or DAPI help identify potential tissue morphology and RNA quality issues. However, these methods are not all-encompassing and may not always correlate exactly to final assay performance.

Estimating RNA Quantity Per Cell

If both DV200 and morphological assessment are both satisfactory, the RNA quantity per cell can be calculated to further assess sample quality. Samples that have good DV200 and good tissue morphology, but low RNA quantity per cell, are not recommended for the Visium HD assay.

2.0 Exposing the Tissue or Facing the Block

Before starting, wipe down all surfaces and work areas with RNaseZap RNase decontaminating solution.

- a. Remove tissue blocks from storage. For a tissue block with already exposed tissue, proceed directly to [RNA Quality Assessment of FFPE Tissue Block on the next page](#).
- b. Set the microtome to the 15 μm setting.
- c. Place tissue block on the specimen clamp.
- d. Cut the tissue block at 15 μm until all of the edges of the tissue are exposed or until the area of interest is exposed. The block should be at **room temperature** during cutting.

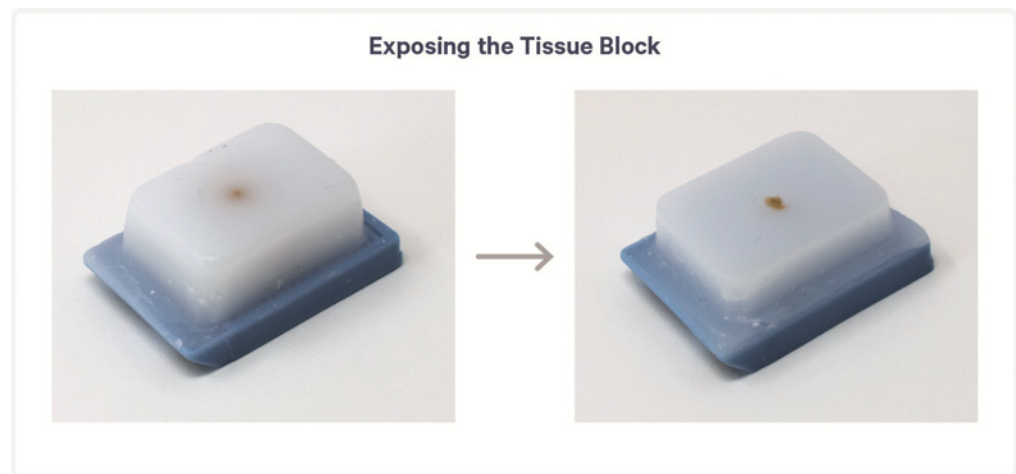

2.1 RNA Quality Assessment of FFPE Tissue Block

This section provides guidance on RNA quality assessment by calculating DV200 of RNA extracted from freshly collected tissue sections.

Mean RNA fragment size is a reliable determinant of RNA quality. This requires a measurement of the percentage of total RNA fragments >200 nucleotides (DV200) for RNA quality assessment upstream of library preparation. For more information on DV200, see [DV200 Performance and Recommendations on page 113](#).

Before starting RNA extraction, apply RNaseZap to a paper towel and wipe work surface, centrifuge rotor and shafts of the pipettes. Rinse with RNase-free water and then wipe dry. The electrodes of the Bioanalyzer can also be cleaned with RNaseZap by following Agilent decontamination procedure.

- a. Set microtome to 5 μm and collect tissue sections for RNA extraction. Discard the first few sections if the block was already exposed. The required number of sections depends upon tissue size. Consult RNA extraction kit manufacturer instructions to determine the appropriate number of sections. See below for guidance:
 - Collect ~2 sections for smaller tissues ($\leq 6.5 \times 6.5 \text{ mm}$)
 - Collect 1-2 sections for larger tissues ($\geq 6.5 \times 6.5 \text{ mm}$)
- b. Place the sections inside a **pre-cooled**, RNase-free microcentrifuge tube. Sections may be stored at **-80°C** for **long-term** storage. For sections stored at **-80°C**, equilibrate to **room temperature** for **5 min** before adding the deparaffinization solution.

TIPS

Place a 5 μm section on a blank slide using the guidance in sections 2.2 and 2.3. RNA quantity per cell estimation is most accurate when adjacent sections are used for RNA extraction and tissue morphology assessments.

- c. Proceed to RNA extraction using RNeasy FFPE Kit and follow manufacturer's instructions.

TIPS

RNA Extraction Tips

- Before Proteinase K digestion, ensure all paraffin is fully dissolved. If solid paraffin remains after the 3 min Deparaffinization step at 56°C, repeat 3 min incubation at 56°C as needed until no visible paraffin remains in the tube.

- Use freshly prepared DNase I aliquots (10 µl per sample). DNase should be reconstituted per kit instructions, aliquoted, and stored at -20°C. Avoid repeated freeze-thaws.
 - During centrifugation steps, verify both the RPM/RCF according to the kit and that the centrifuge chamber is at ambient temperature. Cold temperatures may cause paraffin or debris to re-solidify and pellet, impacting yield.
 - For final elution, use 30 µl RNase-free water.
- d. Using a Nanodrop or Qubit Fluorometer, measure RNA concentration to determine the appropriate dilution for DV200 evaluation using the RNA 6000 Pico Kit or TapeStation High Sensitivity Kit. RNA outside of the recommended concentration may lead to inaccurate DV200 evaluation.
 - e. Store purified RNA at **-80°C** for **long-term** storage or immediately proceed to DV200 evaluation using either the Agilent RNA 6000 Pico Kit or TapeStation High Sensitivity Kit. Follow manufacturer's instructions (Agilent) for DV200 evaluation.

Tissues used with the Visium HD Spatial Gene Expression assay should have a DV200 of > 30%. RNA outside of the recommended concentration may lead to inaccurate DV200 evaluation. For more information on DV200, see [DV200 Performance and Recommendations on page 113](#).

2.2 Sectioning

- a. Place blocks in the ice bath, ensuring that the tissue part is fully submerged.
- b. Incubate on the ice bath for 10–30 min. The incubation time depends upon the tissue type and the extent of dehydration.



Monitor the exposed tissue every 5–10 min during the ice bath incubation. Overhydration may result in adhesion problems. The tissue surface should be smooth and shiny and free of bumps at the end of the incubation. For more information on tissue hydration, see Troubleshooting section.

FFPE Tissue Block in Ice Bath



- c. Carefully wipe off the excess oils from a 35X Ultra disposable blade using a lint-free laboratory wipe with 100% ethanol. Let the ethanol evaporate before proceeding. Always use new blades for sectioning each tissue type.



- d. Secure blade in disposable blade holder of the microtome and place knife guard over the blade to minimize injury. Ensure that the clearance angle is set to 10°.
- e. After hydration is complete, place the tissue block in the specimen clamp and align it with the blade.
- f. Fill up a water bath with Milli-Q or ultrapure water and ensure that the temperature is set at **42°C** and free from bubbles & particulates by gliding a lint-free laboratory wipe over the water surface. Repeat this step between sectioning if necessary.

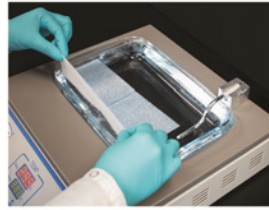

42°C is the recommended water bath temperature for most tissues. See Tips & Best Practices for guidance on optimizing water bath temperature. To visualize the tissue sections better, a Lighted Tissue Floating Bath with LED illumination can be used instead of standard water bath.

Remove Bubbles

- g.** Set the microtome to 5 μm for tissue sectioning and begin sectioning. For tissue blocks with exposed tissue, discard the first few sections and start collection on the subsequent sections.
- h.** To collect sections, place the paintbrush tip slightly above and parallel to the blade. Lift the section by lightly touching the edge with the paintbrush while rotating the wheel handle.
- i.** With the help of the brush, pick the section up. Immediately place it on the water surface of the water bath, making sure that the brush tip goes underneath and away from the section.
- j.** Proceed directly to Section Placement.

2.3 Section Placement

Before proceeding with tissue slides intended for the Visium HD workflow, practice section placement using nonexperimental blocks. Consider the following:

- If placing multiple sections on the blank slide, ensure that sections do not overlap.
- If placing a large section, see [Optional - Area of Interest Annotation on page 13](#) for information on selecting an area of interest.

If using a Nexterion Schott H slide, ensure the slide has been equilibrated to room temperature for 30 min after removing from -20°C storage.

- a. Trace allowable area onto back of the blank slide with a laboratory marker before section placement to ensure compatibility. See [Section Placement on Blank Slides on page 11](#) for more information. Markings will need to be removed before alignment on the Visium CytAssist instrument. Failure to remove markings may result in registration failure due to interference from the marker imprint. This results in incorrect tissue detection.
- b. Allow sections to float for the time previously determined to be optimal.
- c. Hold the blank slide vertically by lifting the top of the blank slide and insert it into the water, aligning the allowable area with the surface of the water while keeping the blank slide straight.
- d. Using the paintbrush or the probe, maneuver the section to the allowable area.



If sections float away from the blank slide, the blank slide can also be dipped into the water bath before sections are placed in the water.

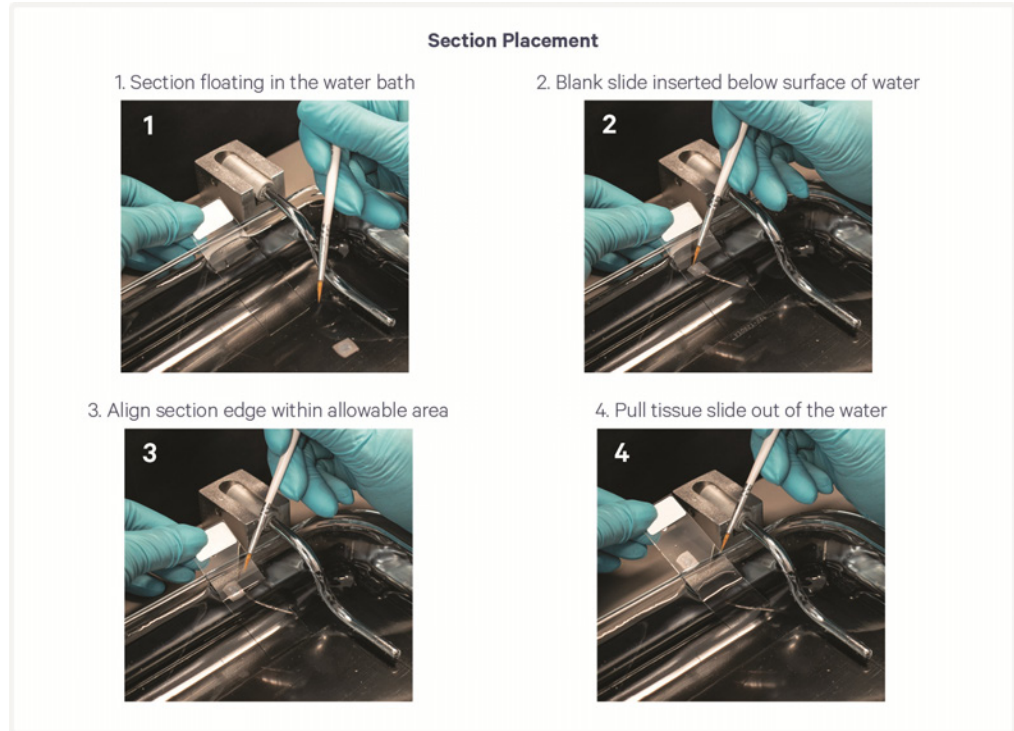

- e. Pull tissue slide up and out of the water, ensuring there are no air bubbles trapped underneath and set aside in a standing rack.
- f. Dry tissue sections upright at room temperature until tissue is opaque and no water remains on top of or under the section. A fan may be used to assist in drying. If no fan is used, slides may require extended drying time for up to **30 min** at **room temperature** to ensure no water remains under the section or until dry (inspect visually, DO NOT touch tissue).



- g. Place the tissue slides in a slide drying rack in a section dryer and incubate for **3 h** in an oven at **42°C**. Alternatively, a thermal cycler set at **42°C** can be used for drying.



See Tips & Best Practices for guidance on slide incubation.

h. Place in a desiccator and keep overnight at **room temperature** to ensure proper drying.



i. After overnight drying, proceed with either optional morphology assessment or one of the staining protocols listed below. If not proceeding with assessment or staining, store the tissue slide containing dry tissue sections at **room temperature** or **4°C** in a desiccator for up to **6 months**.

Staining protocols:

- [H&E Staining on page 68](#)
- [Immunofluorescence Staining on page 94](#)

2.4 Optional DAPI Staining for Tissue Morphology Assessment

If extra tissue slides are available, optional tissue morphology assessment via DAPI and H&E staining is recommended.

Prior to DAPI and H&E staining, deparaffinization is required. Deparaffinize the tissue slide as described in [Deparaffinization on page 66](#). Decrosslinking is not required.

DAPI Staining

- a. Place tissue slide on a flat, clean, nonabsorbent work surface.
- b. Add **500 µl** DAPI solution per slide to uniformly cover all tissue sections.
- c. Incubate **1 min** in the dark at **room temperature**.
- d. Discard reagent by holding slides at an angle with the bottom edge in contact with a laboratory wipe
- e. Add **1 ml** 1X PBS per slide to uniformly cover all tissue sections.
- f. Incubate **1 min** in the dark at **room temperature**.
- g. Discard reagent by holding slides at an angle with the bottom edge in contact with a laboratory wipe
- h. Repeat steps e-g twice more for a total of three washes.

Quality Assessment

Review the DAPI image under the microscope at 20x magnification. Examine several sections within a single DAPI-stained section to ensure assessment is comprehensive. Tissue sections optimal for the assay should have:

- Punctate nuclei that are clearly defined
- DAPI staining that does not appear washed out

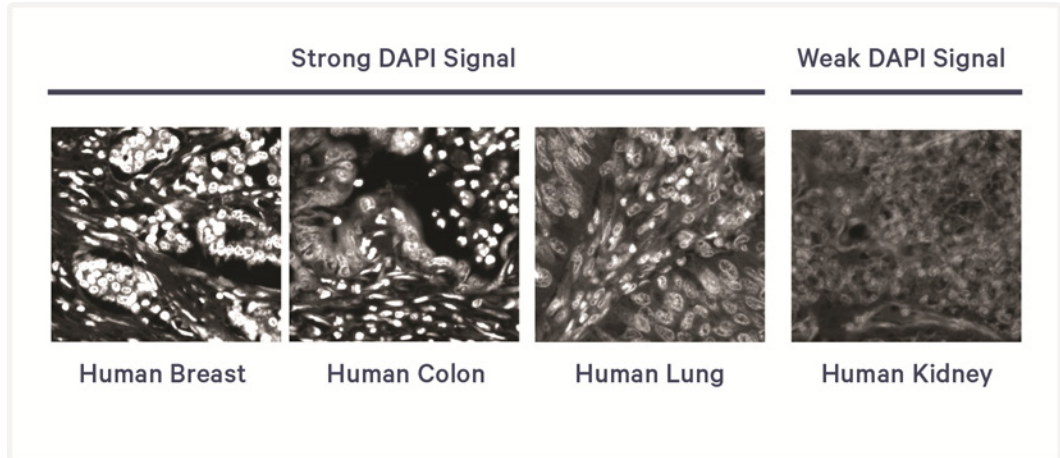

Sections with poor DAPI staining are unlikely to generate good data. All samples in the images below were imaged under the same conditions (405 nm channel). After evaluating DAPI staining, remove coverslip as described in [Coverslip Removal on page 70](#) and proceed to [Optional H&E Staining for Tissue Morphology Assessment](#) below.

2.5 Optional H&E Staining for Tissue Morphology Assessment

Prior to H&E staining, deparaffinization is required. Deparaffinize the tissue slide as described in [Deparaffinization on page 66](#). Decrosslinking is not required.

H&E Staining

Perform H&E staining as described in [H&E Staining on page 68](#), coverslip as described in [Coverslip Mounting](#) and image as described in [Imaging on page 70](#).

Quality Assessment

Ensure that the tissue section is free from tissue processing and sectioning artifacts as shown in the images below and in [Troubleshooting](#). If imaging reveals satisfactory tissue morphology, proceed with the appropriate staining protocol using a different tissue slide.

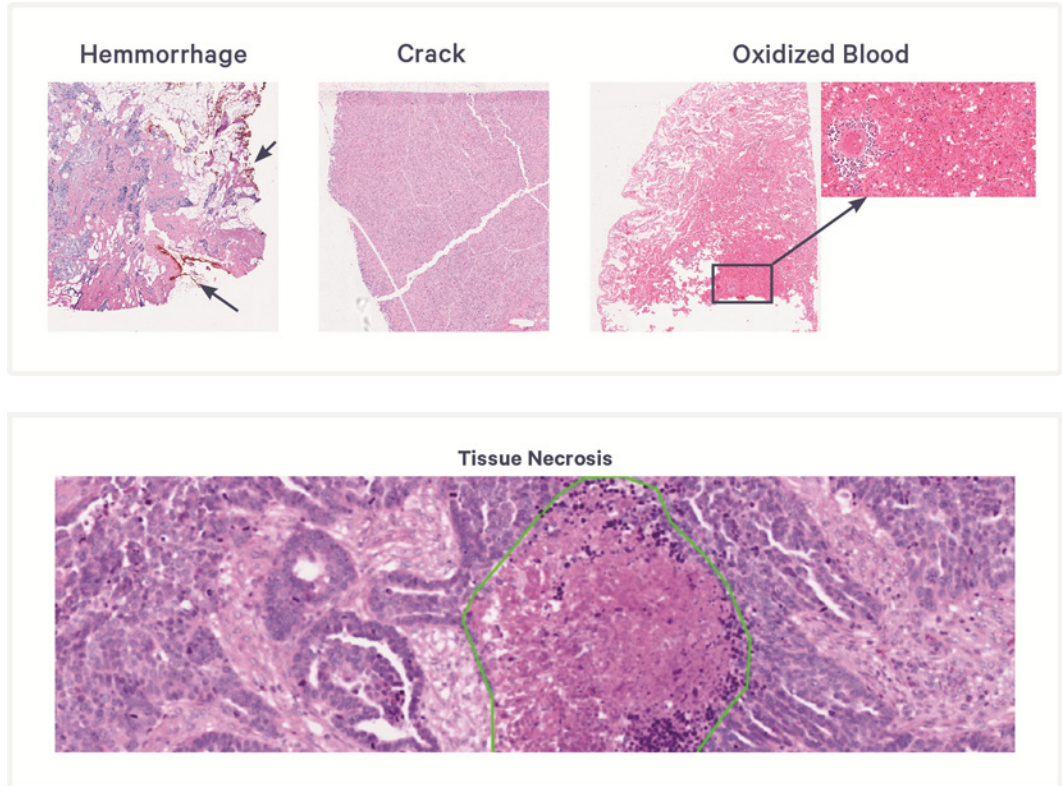

Staining protocol:

- [H&E Staining & Imaging on page 59](#)
- [IF Staining & Imaging on page 76](#)

2.6 RNA Quantity per Cell Estimation

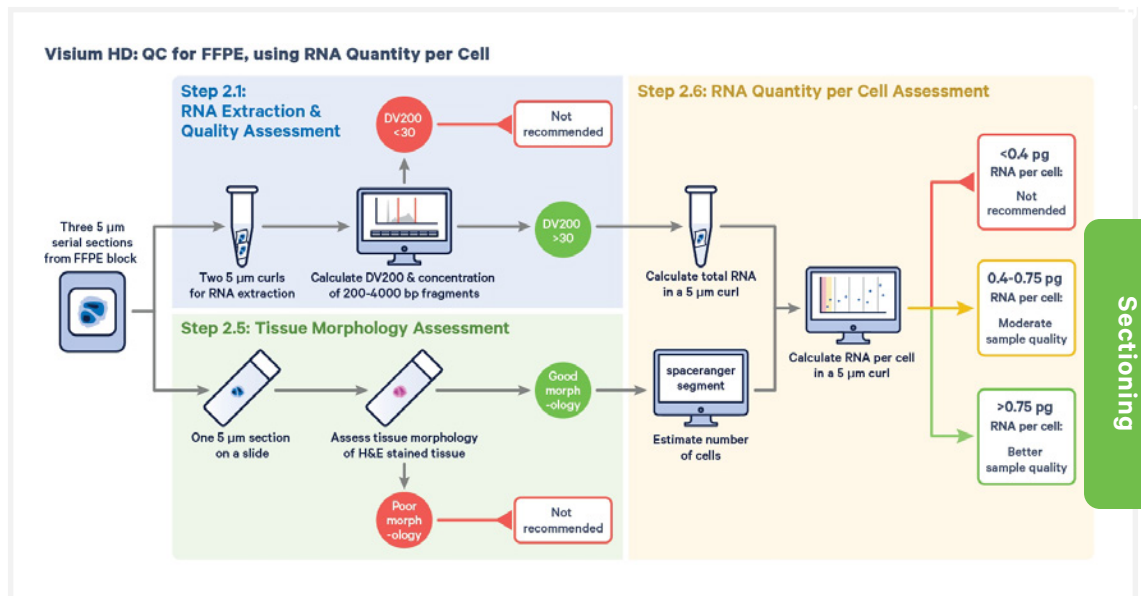

Estimate Total RNA Quantity from 5 µm Section

Using the RNA concentration calculated in [RNA Quality Assessment of FFPE Tissue Block on page 46](#), calculate the total RNA quantity using the formula below.

$$\text{Total RNA in } 5\mu\text{m Section} = \frac{[\text{RNA conc. ng}/\mu\text{l}] \times [\text{Elution Vol. } \mu\text{l, default 30}] \times [\text{Dilut. Factor of RNA in Trace, default 1}]}{[\mu\text{l used for trace, default 1}] \times [\text{number of } 5\mu\text{m curls used for RNA extrac. default 2}]}$$

Example Calculation

$$1,725 \text{ ng RNA in } 5\mu\text{m Section} = \frac{[115 \text{ ng}/\mu\text{l}] \times [30 \mu\text{l}] \times [1]}{[1 \mu\text{l}] \times [2 \text{ curls}]}$$

Estimate Total Number of Cells from 5 µm Section

To normalize the total RNA quantity with respect to cellular density in a 5 µm section, estimate the total number of cells in the H&E image from Step 2 using the “spaceranger segment” nuclear segmentation QC pipeline in Space Ranger v4.0 or greater. The resulting web summary contains an overlay of the H&E image with outlines of segmented nuclei and the total number of nuclei detected.

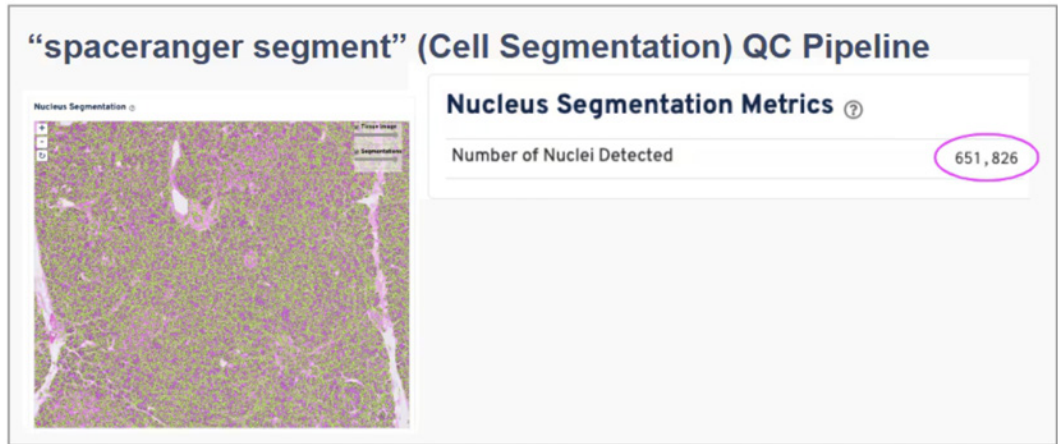

Analysis of H&E images in the absence of sequencing data with “spaceranger segment” is currently not available on 10x Cloud. Spaceranger segment must be run locally. Alternative cell segmentation pipelines may be used but are not supported

Estimate RNA Quantity per Cell

RNA quantity per cell can be calculated by dividing total RNA in a 5 µm section by the estimated number of cells in a 5 µm section. An example is shown below.

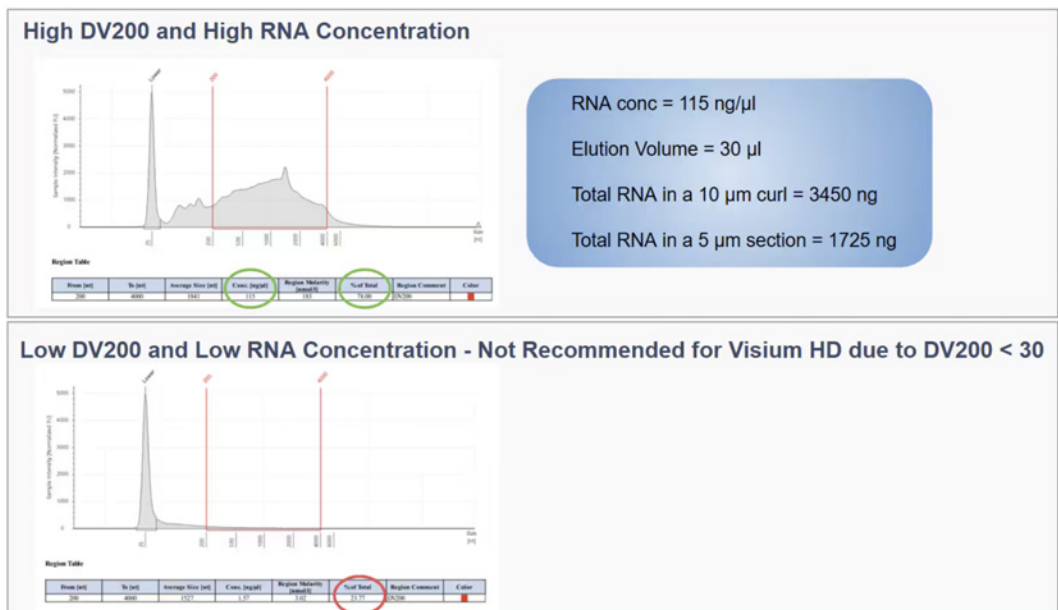

Use RNA Quantity per Cell to Identify Low-quality Samples

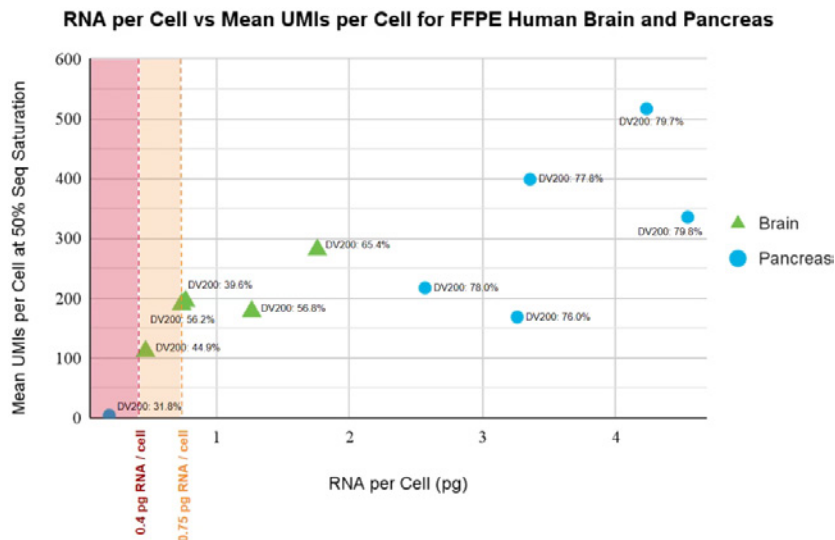

As shown in the image above, RNA quantity per cell is more predictive of assay sensitivity than DV200 at lower amounts of RNA per cell.

Neither DV200 nor RNA quantity per cell strongly correlate with absolute assay sensitivity at higher amounts of RNA per cell. However, assay sensitivity from all samples with >0.75 pg RNA per cell shown here are within expectations and are likely due to variation in fixation conditions and tissue biology between high-quality samples.

To assist with selection of FFPE samples for the Visium HD assay for blocks that have a DV200 > 30%, 10x Genomics recommends the following:

- <0.4 pg RNA per cell: likely poor sample quality. Do not proceed.
- 0.4-0.75 pg RNA per cell: likely moderate sample quality.
- >0.75 pg RNA per cell: likely better sample quality, although some samples may still have lower UMIs per cell due to factors such as fixation condition and tissue biology

The biological properties of a tissue may impact RNA quantity per cell interpretation. For example, tissues with small cells may yield both lower RNA content and UMIs per cell.

3. H&E Staining & Imaging

Overview

This chapter provides guidance on tissue slide deparaffinization, H&E staining, imaging, destaining, and decrosslinking for nonarchived tissue slides. These nonarchived tissue slides should be prepared according to [Tissue Handling, FFPE Tissue Sectioning, Section Placement, and Quality Assessment on page 38](#) prior to starting this chapter. For archived slides, see [Archived Slide Processing on page 25](#)

Ensure that microscope settings have been verified and imaging programs have been created before starting this protocol. Consult the Visium HD Spatial Applications Imaging Guidelines Technical Note (CG000688) for more information. After completing Decrosslinking, proceed immediately to the Visium HD Spatial Gene Expression Reagent Kits 2.0 User Guide (CG001679).

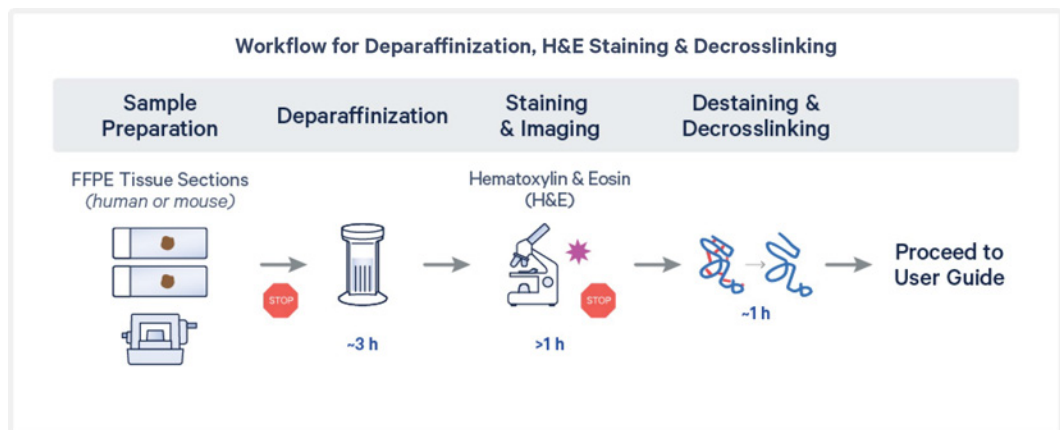

3.0 Get Started

Consult the Visium HD Spatial Gene Expression Protocol Planner (CG000698) for a list of third-party items.

For Deparaffinization

Items	Preparation & Handling
<p>Prepare fresh weekly. Process two slides per jar. Process no more than 20 slides before replacing reagents. Alternatively, use a slide staining dish. Adjust volumes of deparaffinization solutions and water accordingly and ensure volume fully covers tissue.</p>	
<input type="checkbox"/> Xylene	Label two Coplin jars as Xylene Jar 1 and 2. Dispense 30 ml xylene in each.
<input type="checkbox"/> 100% Ethanol	Label two Coplin jars as 100% Ethanol Jar 1 and 2. Dispense 30 ml 100% ethanol in each. Alternatively, use a 50-ml centrifuge tube or beaker.
<input type="checkbox"/> 96% Ethanol	Label two Coplin jars as 96% Ethanol Jar 1 and 2. Dispense 30 ml 96% ethanol in each. Alternatively, use a 50-ml centrifuge tube or beaker.
<input type="checkbox"/> 70% Ethanol	Label one Coplin jar as 70% Ethanol Jar. Dispense 30 ml 70% ethanol. Alternatively, use a 50-ml centrifuge tube or beaker.
<input type="checkbox"/> Milli-Q or UltraPure Water	Label one Coplin jar as WaterJar. Dispense 30 ml water. Alternatively, use a 50-ml centrifuge tube or beaker.

For H&E Staining

Items	Preparation & Handling
<input type="checkbox"/> Milli-Q or UltraPure Water	Label six 1000-ml beakers as Water Beakers 1–6. Dispense 800 ml of water into each beaker. Dispensed volumes in each beaker can be used for two slides. Alternatively, use 50-ml centrifuge tubes instead of beakers (one tissue slide per 50-ml centrifuge tube).
<input type="checkbox"/> Alcoholic Eosin	Prepare 30 ml in a 50-ml conical tube for each tissue slide.
<input type="checkbox"/> Gill II Hematoxylin	
<input type="checkbox"/> Bluing Buffer	

For Coverslip Mounting

Items	Preparation & Handling																									
Prepare																										
<input type="checkbox"/> Mounting Medium	The dilution below is not necessary if stock glycerol is already at 85%. Invert to mix or vortex. Briefly centrifuge to remove bubbles. Inspect for bubbles. Continue centrifuging until no bubbles remain.																									
	<table border="1"> <thead> <tr> <th>Mounting Medium <i>1 slide = 1 Tissue Slide</i></th> <th>Stock</th> <th>Final</th> <th>1 Slide (μl)</th> <th>2 Slides +20% (μl)</th> <th>4 Slides +15% (μl)</th> </tr> </thead> <tbody> <tr> <td>Glycerol</td> <td>100%</td> <td>85%</td> <td>127.5</td> <td>306.0</td> <td>612.0</td> </tr> <tr> <td>Nuclease-free Water</td> <td>100%</td> <td>-</td> <td>22.5</td> <td>54.0</td> <td>108.0</td> </tr> <tr> <td>Total</td> <td>-</td> <td>-</td> <td>150.0</td> <td>360.0</td> <td>720.0</td> </tr> </tbody> </table>	Mounting Medium <i>1 slide = 1 Tissue Slide</i>	Stock	Final	1 Slide (μ l)	2 Slides +20% (μ l)	4 Slides +15% (μ l)	Glycerol	100%	85%	127.5	306.0	612.0	Nuclease-free Water	100%	-	22.5	54.0	108.0	Total	-	-	150.0	360.0	720.0	
Mounting Medium <i>1 slide = 1 Tissue Slide</i>	Stock	Final	1 Slide (μ l)	2 Slides +20% (μ l)	4 Slides +15% (μ l)																					
Glycerol	100%	85%	127.5	306.0	612.0																					
Nuclease-free Water	100%	-	22.5	54.0	108.0																					
Total	-	-	150.0	360.0	720.0																					
Obtain																										
<input type="checkbox"/> Coverslip	-																									

For Destaining

Items	Preparation & Handling		Storage															
Obtain																		
<input type="checkbox"/> 0.1 N HCl	If necessary, prepare 0.1 N HCl using nuclease-free water.		Ambient															
	<table border="1"> <thead> <tr> <th>0.1 N HCl <i>1 slide = 1 Tissue Slide</i></th> <th>Stock</th> <th>Final</th> <th>2 Slides (ml)</th> </tr> </thead> <tbody> <tr> <td>HCl</td> <td>1 N</td> <td>0.1 N</td> <td>0.2</td> </tr> <tr> <td>Nuclease-free Water</td> <td>100%</td> <td>-</td> <td>1.8</td> </tr> <tr> <td>Total</td> <td>-</td> <td>-</td> <td>2</td> </tr> </tbody> </table>	0.1 N HCl <i>1 slide = 1 Tissue Slide</i>	Stock	Final	2 Slides (ml)	HCl	1 N	0.1 N	0.2	Nuclease-free Water	100%	-	1.8	Total	-	-	2	
0.1 N HCl <i>1 slide = 1 Tissue Slide</i>	Stock	Final	2 Slides (ml)															
HCl	1 N	0.1 N	0.2															
Nuclease-free Water	100%	-	1.8															
Total	-	-	2															
<input type="checkbox"/> Visium Tissue Slide Cassette	-		Ambient															
<input type="checkbox"/> Slide Seals	-		Ambient															
<input type="checkbox"/> TE Buffer (10 mM Tris and 1 mM EDTA), pH 8.0	-		Ambient															
<input type="checkbox"/> 1X PBS	Prepare 2 ml of 1X PBS. This volume of 1X PBS is sufficient for both destaining and decrosslinking. If using 10X PBS stock, prepare 2 ml 1X PBS from 10X stock using nuclease-free water.		Ambient															

H&E Staining & Imaging

For Decrosslinking

Items	10x PN	Preparation & Handling	Storage
Heat to 37°C			
<input type="checkbox"/> ●	Decrosslinking Buffer B 2001094	Pre-heat thermomixer or water bath to 37°C. Thaw in a thermomixer (300 rpm with shaking) or water bath for 30 min at 37°C during Destaining.	-20°C
Equilibrate to room temperature			
<input type="checkbox"/> ●	Perm Enzyme B 3000553	Remove from -20°C shortly before use. Maintain at room temperature. Pipette mix, centrifuge briefly. DO NOT vortex.	-20°C
<input type="checkbox"/> ●	Decrosslinking Buffer B 2001094	After heating to 37°C as indicated above, cool to room temperature for 5 min. Vortex for 30 sec and centrifuge briefly.	-20°C
Obtain			
<input type="checkbox"/>	Nuclease-free Water	-	Ambient
<input type="checkbox"/>	8M Urea	-	Ambient

3.1 Protocol Overview

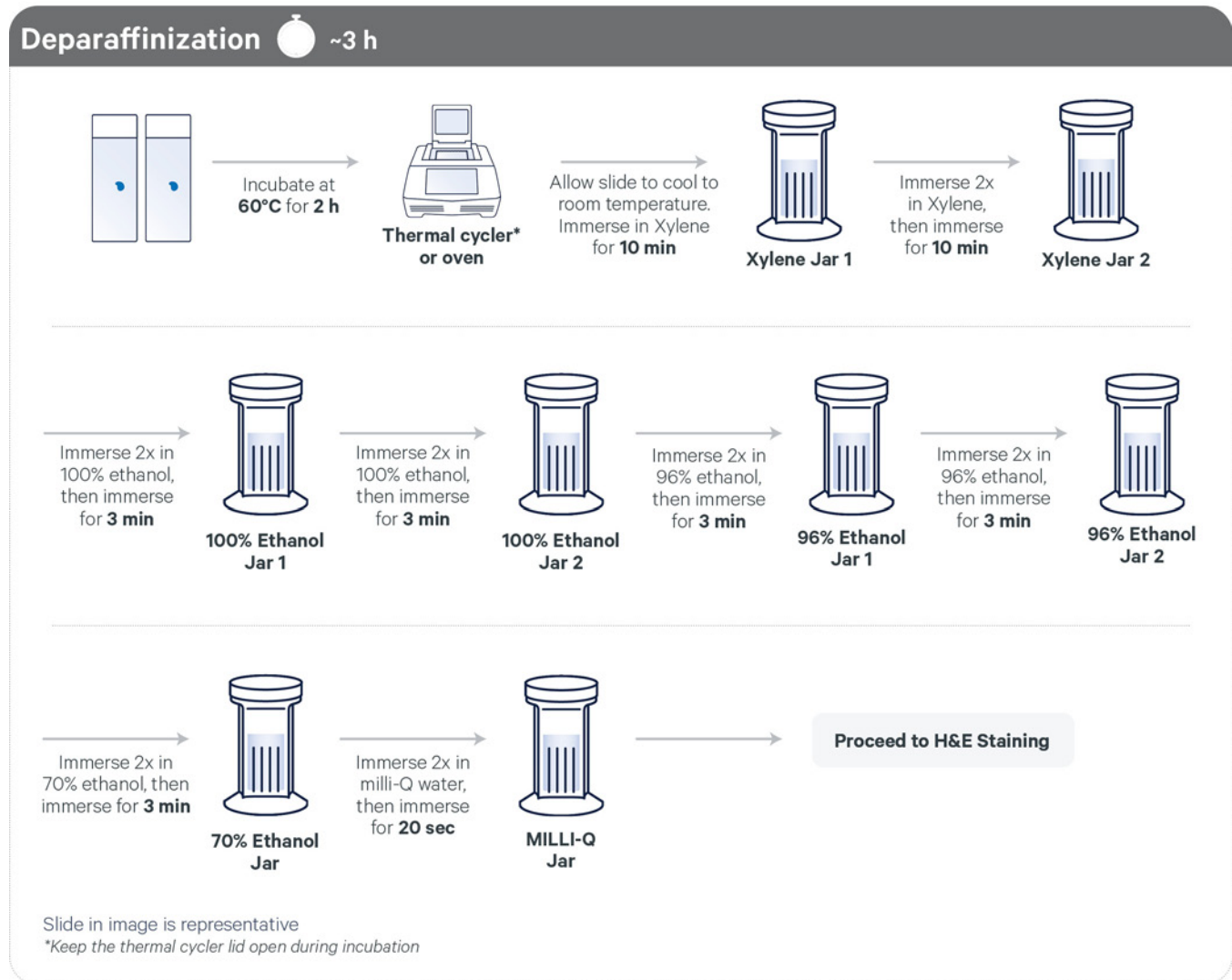

H&E Staining & Imaging

H&E Staining & Coverslipping ~15 min



*Wipe excess liquid from the back of the slide after each immersion series

Destaining ☾ ~30 min

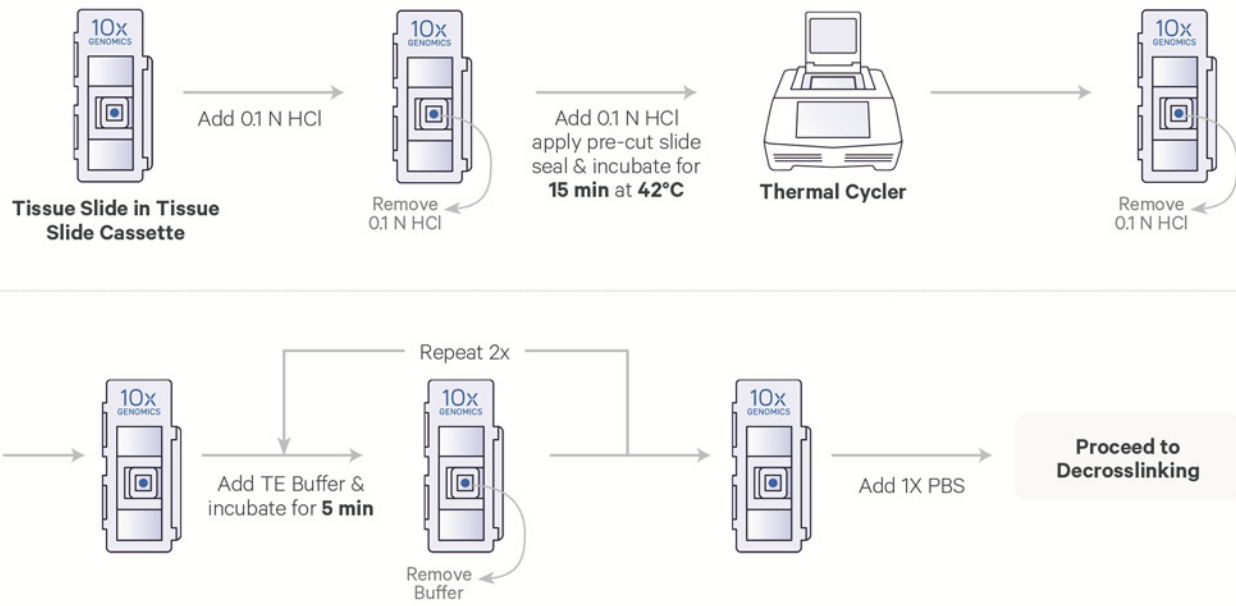

Decrosslinking ☾ ~30 min

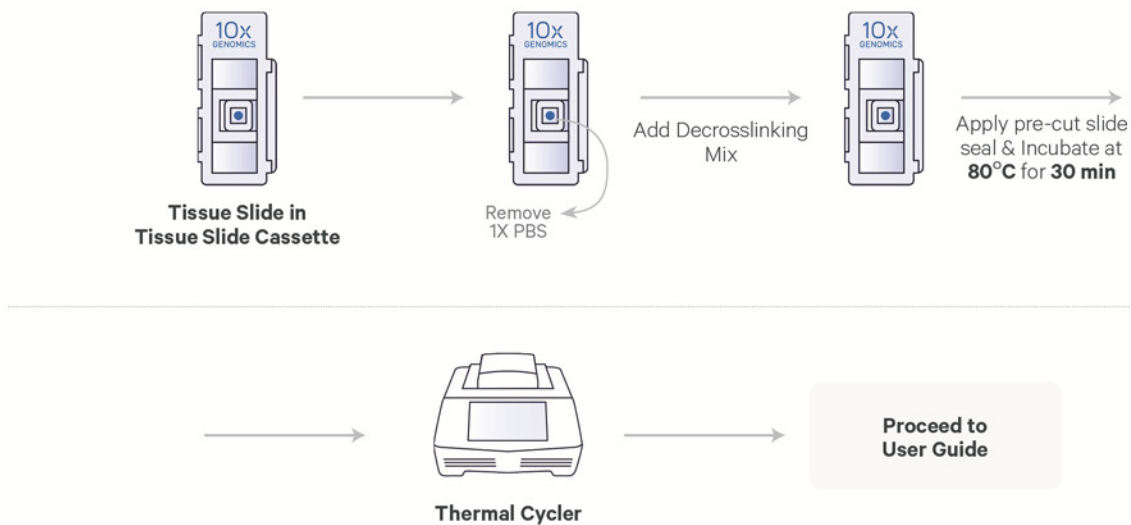

H&E Staining & Imaging

3.2 Deparaffinization

Deparaffinization steps should be performed in a fume hood due to the hazardous nature of xylene. If slides were stored at 4°C, allow slides to come to room temperature prior to deparaffinization.

- a. Retrieve slides with tissue sections from desiccator after overnight drying. If tissue slides were stored at 4°C, place slides in a rack and leave at room temperature for **5 min**.
- b. Place slides in a rack sideways in a Section Dryer Oven and incubate uncovered at **60°C** for **2 h**. Keep oven lid closed during incubation.

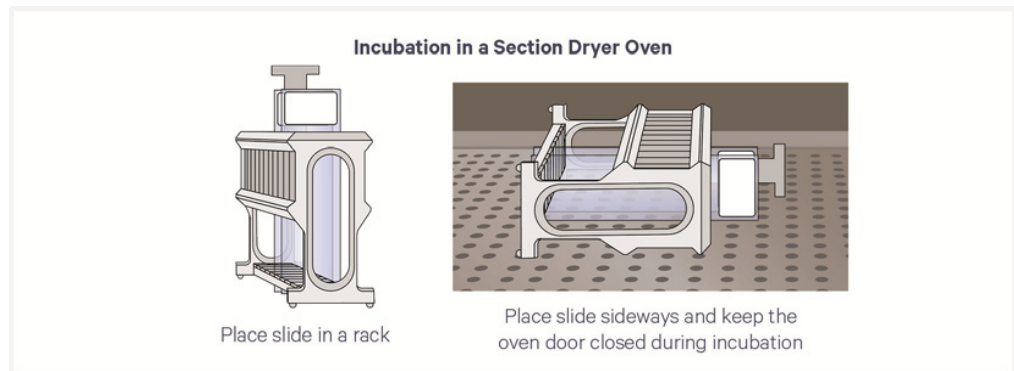

Alternatively, place a Low Profile Thermocycler Adapter on a thermal cycler set at **60°C**. Place slide on the Low Profile Thermocycler Adapter with the tissue side facing up and incubate **2 h** at **60°C**.



DO NOT close the thermal cycler lid.

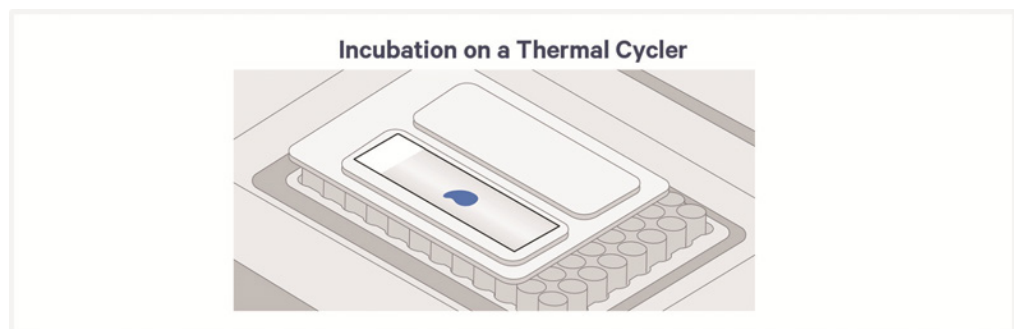

- c. Remove slides from the oven or thermal cycler and allow to cool down to room temperature for **5 min**. Exercise caution, as slides are hot.



When immersing slides in xylene, ensure that the tissue sections are completely submerged.

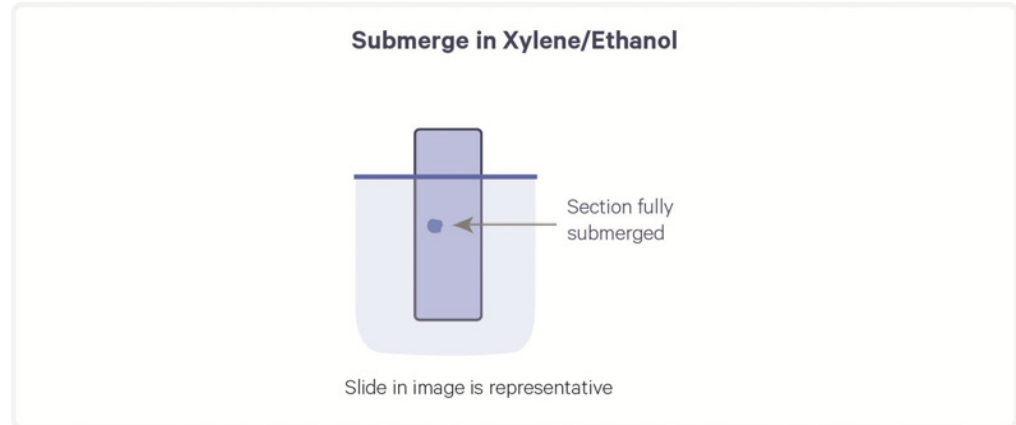

- d. Gently immerse slides 2x in Xylene Jar 1, then immerse and incubate for **10 min**. Secure jar cap to prevent xylene loss.
- e. Gently immerse slides 2x in Xylene Jar 2, then immerse and incubate for **10 min**. Secure jar cap to prevent xylene loss.
- f. Gently immerse slides 2x in 100% Ethanol Jar 1, then immerse and incubate for **3 min**.
- g. Gently immerse slides 2x in 100% Ethanol Jar 2, then immerse and incubate for **3 min**.
- h. Gently immerse slides 2x in 96% Ethanol Jar 1, then immerse and incubate for **3 min**.
- i. Gently immerse slides 2x in 96% Ethanol Jar 2, then immerse and incubate for **3 min**.
- j. Gently immerse slides 2x in 70% Ethanol Jar, then immerse and incubate for **3 min**.
- k. Gently immerse slides 2x in Water Jar, then immerse and incubate for **20 sec**.
- l. Proceed **immediately** to Staining & Coverslip Mounting.



DO NOT let the slides dry.

3.3 H&E Staining

- a. Place slide on a flat, clean, nonabsorbent work surface. Some residual droplets may remain.
- b. Add **1 ml** Hematoxylin per slide to uniformly cover all tissue sections. DO NOT pipette directly onto tissue sections.



If staining two tissue slides at a time, ensure that hematoxylin is discarded quickly after incubation to prevent overstaining.

- c. Incubate **1 min** at **room temperature**.



- d. Discard reagent by holding slides at an angle with the bottom edge in contact with a lint-free laboratory wipe.
- e. Immerse slides 5x in Water Beaker 1.
- f. Immerse slides 15x in Water Beaker 2.
- g. Immerse slides 15x in Water Beaker 3.
- h. Wipe excess liquid from back of slides with a lint-free laboratory wipe without touching the tissue section.
- i. Place slide on a flat, clean, nonabsorbent work surface. Some droplets may remain.
- j. Add **1 ml** Bluing Buffer per slide to uniformly cover all tissue sections.
- k. Incubate **1 min** at **room temperature**.
- l. Discard reagent by holding slides at an angle with the bottom edge in contact with a lint-free laboratory wipe.
- m. Immerse slides 15x in Water Beaker 4.

- n. Wipe excess liquid from back of slides with a lint-free laboratory wipe without touching the tissue section. Place on a flat, clean, nonabsorbent work surface. Some droplets may remain.
- o. Gently immerse slides in alcoholic Eosin solution in separate 50-ml centrifuge tubes. DO NOT use diluted Eosin.
- p. Incubate **1 min** at **room temperature**.
- q. Discard reagent by holding slides at an angle with the bottom edge in contact with a lint-free laboratory wipe.
- r. Immerse slides for **30 sec** in Water Beaker 5.
- s. Immerse slides 10x in Water Beaker 6.
- t. Wipe excess liquid from back of slides with a lint-free laboratory wipe without touching the tissue section.

Excess liquid may dilute the Mounting Medium, causing the coverslip to come loose.



DO NOT air dry the slides.

3.4 Coverslip Mounting

- a. Gently touch the long edge of the slide on a lint-free laboratory wipe to remove excess moisture. Ensure any large droplets are removed.
- b. Place slides on a flat, clean, nonabsorbent work surface. Some residual droplets may remain.
- c. Using a **wide-bore** pipette tip, add **100–150 µl** Mounting Medium to cover all tissue sections uniformly.

Tissue slides with large sections or multiple sections may require more Mounting Medium.

- d. Slowly apply coverslip at an angle on one end of the slides, without introducing bubbles. Allow Mounting Medium to spread and settle.



- e. Remove any large excess of Mounting Medium by carefully wicking away from the edge of the coverslip using a lint-free laboratory wipe. Do not move coverslip and disturb tissue.
-  f. **Immediately** proceed with imaging or store slides laying flat in a slide holder. Store slides at **4°C** for up to **24 h**. Ensure that slides are laid flat to prevent loss of Mounting Medium.

If storing slides for longer is desired, **immediately** proceed with imaging and follow stop instructions in [Coverslip Removal below](#). The stopping point above and the stopping point in [Coverslip Removal below](#) cannot be combined.

3.5 Imaging

- a. Image tissue section of interest at desired magnification using brightfield imaging settings. Consult the Visium HD Spatial Applications Imaging Guidelines Technical Note (CG000688) for additional information.
- b. If using the Visium CytAssist Alignment Aid to annotate the square window, do so now while the tissue slide is coverslipped. This annotation assists in gasket placement during cassette assembly. For more information, consult [Visium CytAssist Alignment Aid on page 22](#).
- c. Proceed **immediately** to Coverslip Removal.

3.6 Coverslip Removal

- a. Dispense **800 ml** Milli-Q water in a beaker. Up to 10 slides may be processed using this beaker.
- b. Immerse slides **sideways** in the beaker containing **800 ml** water with coverslipped surface fully sideways to prevent coverslip from dragging across tissue.
- c. Hold slides in water until the coverslip slowly separates away from the slide.



To avoid tissue section damage or detachment, DO NOT move slide up and down, shake forcibly, or manually move coverslip.

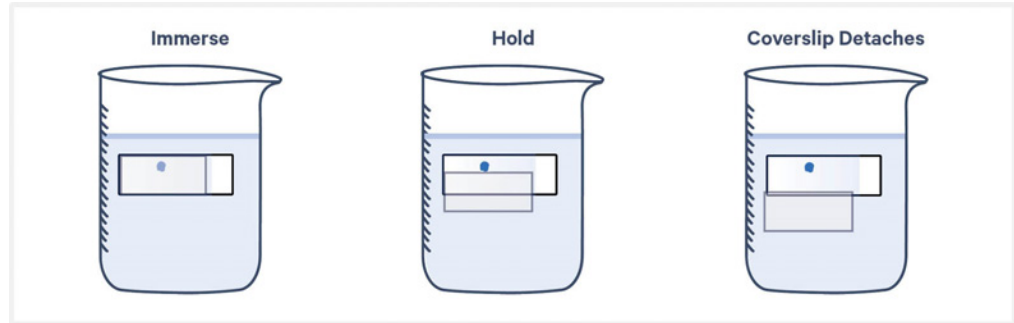

- d. Gently immerse slides **30x** in water to ensure all Mounting Medium is removed.
- e. Wipe back of slide with a lint-free laboratory wipe.
- f. Place slide on a flat, clean, nonabsorbent work surface and air dry for **5 min**.
- g. Incubate slide on Low Profile Thermocycler Adapter with thermal cycler lid open for **3 min** at **37°C**. Ensure tissue is completely dry. If necessary, wipe droplets around tissue with a lint-free laboratory wipe.
-  h. Proceed **immediately** to Destaining or store slides laying flat in a slide mailer or slide holder at **4°C** in the dark with desiccant for up to **2 weeks**. Ensure slides do not touch one another and that desiccant does not come in contact with tissue slide.

3.7 Destaining

■ denotes volumes for 6.5 mm gaskets and ▲ denotes volumes for 11 mm gaskets.

- a. Place a Low Profile Thermocycler Adapter in the thermal cycler. Prepare thermal cycler with the following incubation protocol and start the program.

Lid Temperature	Reaction Volume	Run Time
42°C (lid may be set to lowest temperature if instrument does not enable 42°C)	100 µl	15 min
Step	Temperature	Time hh:mm:ss
Pre-equilibrate	42°C	Hold
Destaining	42°C	00:15:00
Hold	22°C	Hold

- b. Place slide in a Tissue Slide Cassette, centering the tissue or area of interest.

See Visium Cassette S3 Quick Reference Card (CG000730) for assembly instructions. Practice assembly with a blank slide.
- c. If the alignment aid was used to annotate the square window, remove the marks with a lint-free laboratory wipe and 70% isopropanol or 70% ethanol.
- d. Add **■ 150 μ l** or **▲ 300 μ l** 0.1 N HCl along the side of the wells to uniformly cover tissue sections, without introducing bubbles. Tilt and tap cassette gently to ensure uniform coverage.
- e. Remove HCl from wells.

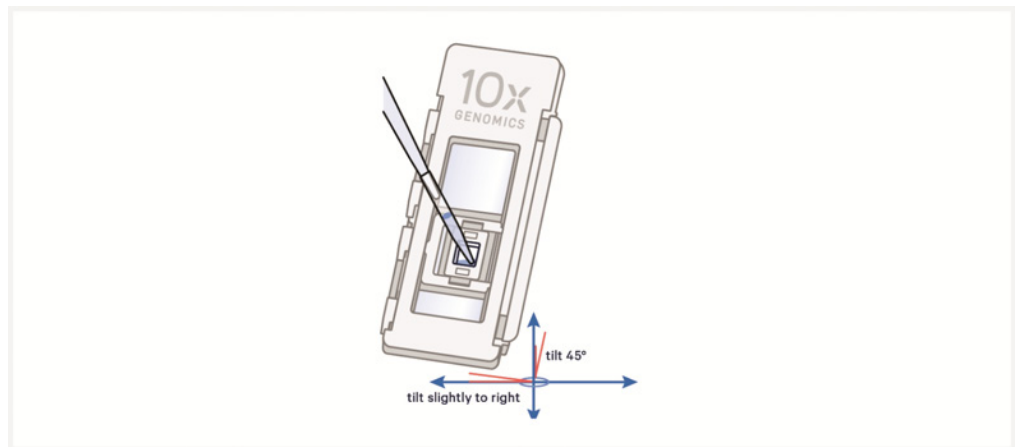

- f. Add **■ 100 μ l** or **▲ 250 μ l** 0.1 N HCl along the side of the wells to uniformly cover tissue sections, without introducing bubbles. Tap cassette gently to ensure uniform coverage.
- g. Apply pre-cut slide seal on cassette and place cassette on Low Profile Thermocycler Adapter at **42°C**. See Tips & Best Practices for more information on cassette incubation in a thermal cycler.

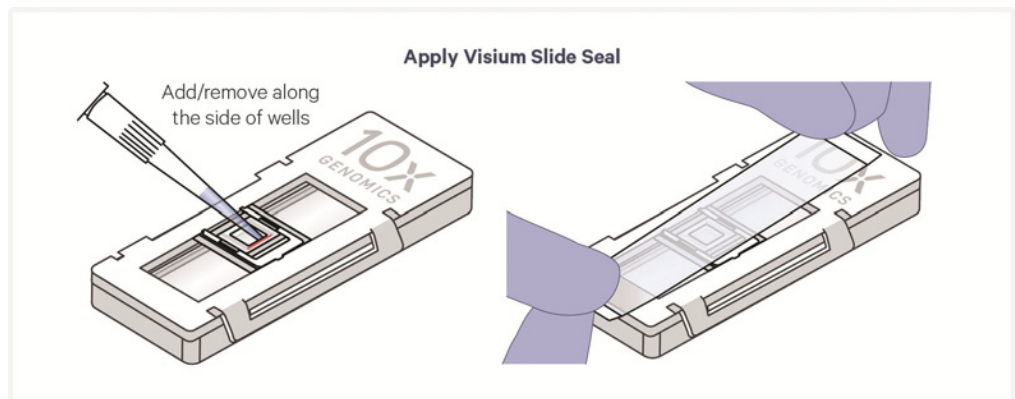

- h. Close thermal cycler lid. Skip Pre-equilibrate step to initiate Destaining.
- i. Remove cassette from Low Profile Thermocycler Adapter and place on a flat, clean work surface.



Some color remaining in the tissue after thermal cycler incubation is normal.

- j. Peel back slide seal and using a pipette, remove all the HCl from well corners.

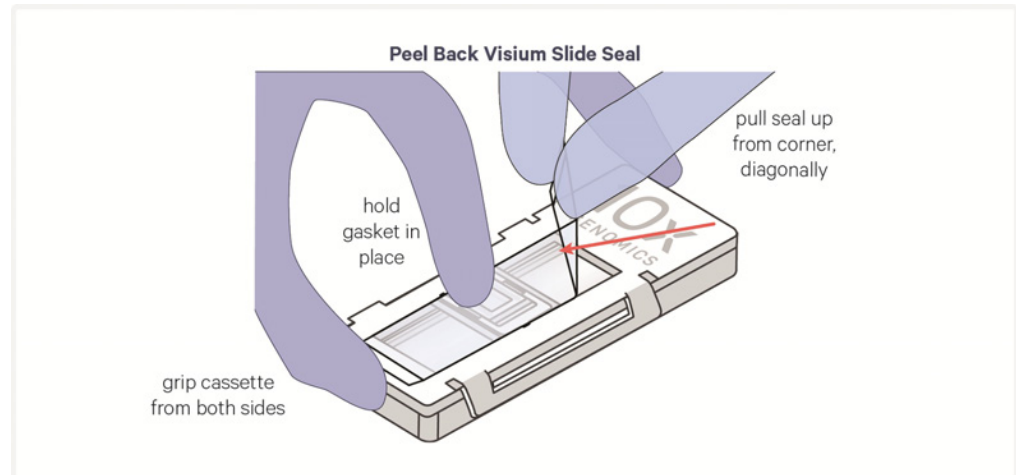

Three TE Buffer washes:

- k. **Wash 1:** Add ■ 150 µl or ▲ 300 µl TE Buffer (pH 8.0) along the side of the wells. Incubate for **5 min** at **room temperature**. Remove TE Buffer from the wells.
- l. **Wash 2:** Add ■ 150 µl or ▲ 300 µl TE Buffer (pH 8.0) along the side of the wells. Incubate for **5 min** at **room temperature**. Remove TE Buffer from the wells.
- m. **Wash 3:** Add ■ 150 µl or ▲ 300 µl TE Buffer (pH 8.0) along the side of the wells. Incubate for **5 min** at **room temperature**. Remove TE Buffer from the wells.
- n. Add ■150 µlor ▲300 µl 1X PBS along the side of the wells.
- o. Re-apply slide seal.

3.8 Decrosslinking

■ denotes volumes for 6.5 mm gaskets and ▲ denotes volumes for 11 mm gaskets.



Ensure Decrosslinking Buffer B has been prepared according to [Preparation - Buffers](#).

- a. Prepare thermal cycler with the following incubation protocol.

Lid Temperature	Reaction Volume	Run Time
80°C	100 µl	40 min
Step	Temperature	Time hh:mm:ss
Hold	22°C	Hold
Decrosslinking	80°C	00:30:00
Re-equilibrate	22°C	00:10:00
Hold	22°C	Hold



- b. Prepare Diluted Perm Enzyme B according to the table below. Add reagents in the order listed. Mix thoroughly with a P20 pipette set to 17 µl. Maintain at room temperature.

Diluted Perm Enzyme B	Stock	Final	10x PN	Total Amount (µl)
1X PBS	-	-	-	16.8
Perm Enzyme B <i>(Maintain at room temperature. Pipette mix, centrifuge briefly. DO NOT vortex).</i>	-	-	3000553	3.2
Total	-	-	-	20

- c. Prepare Decrosslinking Mix according to the appropriate table below. Add reagents in the order listed. Pipette mix thoroughly. Centrifuge briefly. Maintain at room temperature.

6.5 mm

6.5 mm Gaskets							
Decrosslinking Mix 1 slide = 1 Tissue Slide	Stock	Final	10x PN	1 slide (µl)	2 slides + 10% (µl)	4 slides + 10% (µl)	
Decrosslinking Buffer B	-	-	2001094	92.50	203.50	407.00	
Urea	8 M	0.5 M	-	6.25	13.75	27.50	
Diluted Perm Enzyme B (prepared in step b)	-	-	-	1.25	2.75	5.50	
Total	-	-	-	100	220	440	

11 mm

11 mm Gaskets							
Decrosslinking Mix 1 slide = 1 Tissue Slide	Stock	Final	10x PN	1 slide (µl)	2 slides + 10% (µl)	4 slides + 10% (µl)	
Decrosslinking Buffer B	-	-	2001094	185.0	407.0	814.0	
Urea	8 M	0.5 M	-	12.5	27.5	55.0	
Diluted Perm Enzyme B (prepared in step b)	-	-	-	2.5	5.5	11.0	
Total	-	-	-	200	440	880	

- d. Remove slide seal and remove 1X PBS from the wells.
- e. Add ■ **100 µl** or ▲ **200 µl** Decrosslinking Mix along the side of the wells
- f. Apply a new pre-cut slide seal on the cassette and place cassette on the Low Profile Thermocycler Adapter. See Tips & Best Practices for more information on cassette incubation in a thermal cycler.
- g. Close and tighten thermal cycler lid. Skip Pre-equilibrate step and initiate Decrosslinking.
- h. Proceed **immediately** to Visium HD Spatial Gene Expression Reagent Kits 2.0 User Guide (CG001679).

TIPS

4. IF Staining & Imaging

Overview

This chapter provides guidance on deparaffinization, decrosslinking, and immunofluorescence (IF) staining, coverslip mounting, imaging, and coverslip removal for nonarchived tissue slides. These nonarchived tissue slides should be prepared according to [Tissue Handling, FFPE Tissue Sectioning, Section Placement, and Quality Assessment on page 38](#) prior to starting this chapter. Archived IF slides have not been tested by 10x Genomics. This chapter also provides guidance on optimizing antibodies. After coverslip removal, proceed immediately to the Visium HD Spatial Gene Expression Reagent Kits 2.0 User Guide (CG001679).

- ⚠ One additional Tissue Slide Cassette (Visium Tissue Slide Cassette S3 6.5 mm, 4 pk PN-1000684 or Visium Tissue Slide Cassette, 11 mm, 2pk PN-1001030) is required for each processed Tissue Slide.
- ⚠ A Visium 8-port Cassette S3, 4 pk (PN-1000685) must be purchased to perform antibody optimization.



Verify microscope settings and create imaging programs prior to starting this step. Consult the Visium HD Spatial Applications Imaging Guidelines Technical Note (CG000688) for more information.

Separate protocols are provided in this chapter if fluorophore-conjugated primary antibodies are used vs. if primary and secondary antibodies are used.

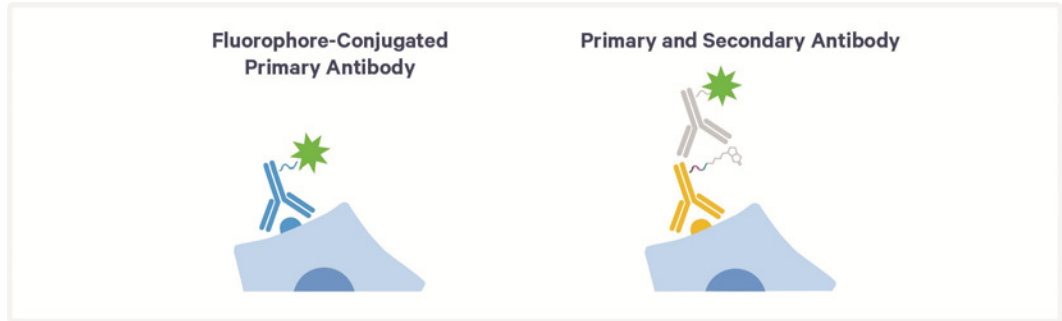

Antibody Optimization

Prior testing of the antibodies is recommended on the same tissue block before performing immunofluorescence staining in combination with the Visium HD Spatial Gene Expression workflow. Determination of the optimal antibody concentration is crucial for successfully executing this protocol.

The amount of Decrosslinking Buffer provided in the kit is enough to perform antibody optimization, while still leaving enough reagent for the main assay.

6.5 mm Slides		
Reagent	PN	Reactions* Available for Optimization
Decrosslinking Buffer B	2001094	8

*Reactions refer to the number of antibody dilutions that can be prepared, given the volume of each well in the Visium Cassette. For example, the example dilution series below tests seven antibody optimization reactions.

Optimal antibody concentrations for this Demonstrated Protocol may differ from other applications. Composition of reagents and buffers may also differ from other immunofluorescence applications.

Ensure that enough reactions are available for the main assay after running optimization experiments.

When optimizing the antibody for a single tissue type, ensure that stained slides can be imaged according to the imaging guidelines listed in Visium HD Spatial Applications Imaging Guidelines Technical Note (CG000688).

Below is a suggested optimization workflow. Antibody optimization may be performed according to preference, as long as tissues are tested using the immunofluorescence staining protocol described in this document.

- Draw representative frames on the back of a blank slide using the example slide layout for a 25 mm wide slide.

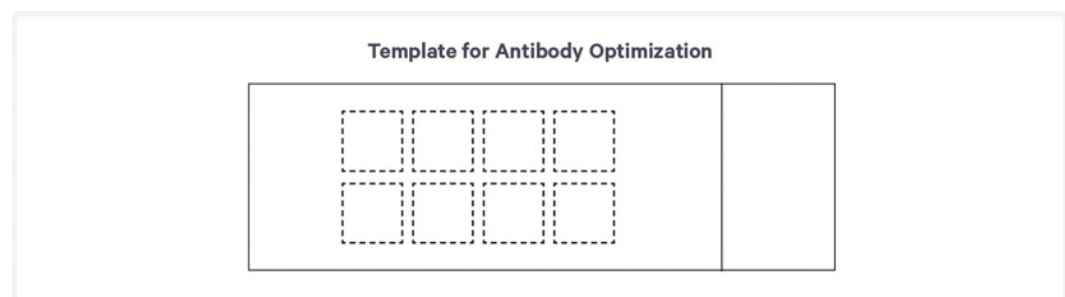

- Trim tissue sections to fit within each 6.5 mm area on the template. *Irrespective of the size of the Visium Cassette used in the experiment, 6.5*

mm area is used for optimization purposes.

- Place tissue sections in the frames on the front of the slide for compatibility with the Visium Cassette.
- Execute the Deparaffinization, Decrosslinking & Immunofluorescence Staining protocol using a range of antibody concentrations, testing multiple concentrations on the same tissue slide. A starting concentration of 0.01 $\mu\text{g}/\mu\text{l}$ (0.7 $\mu\text{g}/\text{sample}$) is recommended.
- To reduce autofluorescence, TrueBlack reagent may be added.
- Select the antibody concentration that results in the specific staining of desired cells, while minimizing nonspecific background staining.

Autofluorescence quenchers are added following immunofluorescence staining and may result in the reduction of fluorescence signal. Additional optimization and increase in antibody concentration may be required to properly visualize immunostaining.

An example dilution layout is provided below. DAPI and merged images are provided to show the presence of breast cancer tissue for each antibody dilution. Dilutions are of recombinant Anti-Vimentin antibody conjugated to Alexa Fluor 594 (BioLegend, PN677804, 0.5 mg/ml). A 1:100 dilution (0.35 $\mu\text{g}/\text{sample}$) was considered optimal in this example.

Example calculations:

Stock antibody concentration is 0.5 $\mu\text{g}/\mu\text{l}$ and desired concentration is 0.01 $\mu\text{g}/\mu\text{l}$ (50X dilution).

Reagents	Stock	Final	Volume (μl)
PBS	10X	1X	7.0
BSA	10%	2%	14.0
RNase Inhibitor	40X	2X	3.5
Tween-20	10%	0.1%	0.7
Antibody	0.5 $\mu\text{g}/\mu\text{l}$	0.01 $\mu\text{g}/\mu\text{l}$	1.4
DAPI Solution	100X	0.5X	0.4
Nuclease-free Water			43.0
Total			70.0

Stock antibody concentration is 0.5 $\mu\text{g}/\mu\text{l}$ and desired concentration is 0.0025 $\mu\text{g}/\mu\text{l}$ (200X dilution).

- This calculation requires pipetting a very small volume of antibody. Dilute the stock concentration first. In the example below, the stock antibody is

diluted 10X to 0.05 µg/µl. Proceed with the following reagent table:

Reagents	Stock	Final	Volume (µl)
PBS	10X	1X	7.0
BSA	10%	2%	14.0
RNase Inhibitor	40X	2X	3.5
Tween-20	10%	0.1%	0.7
Antibody	0.05 µg/µl*	0.0025 µg/µl	3.5
DAPI Solution	100X	0.5X	0.4
Nuclease-free Water			40.9
Total			70.0

*Diluted antibody stock

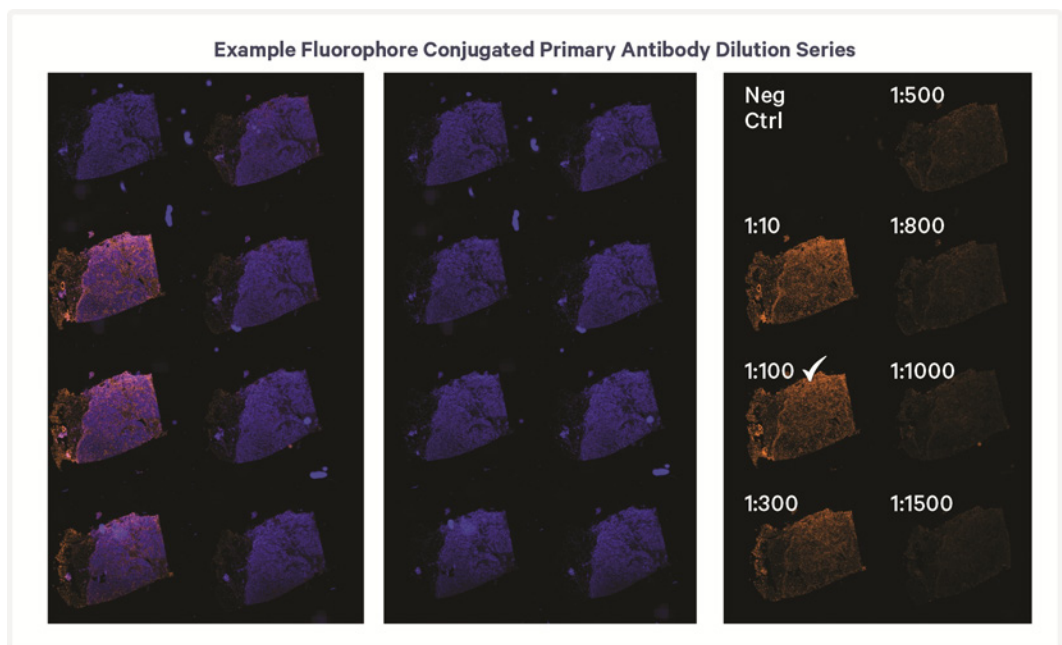

4.0 Get Started

Consult the Visium HD Spatial Gene Expression Protocol Planner (CG000698) for a list of third-party items. If using slide containers other than slide mailers (where applicable), reagent volumes will need to be scaled appropriately.

For Deparaffinization

Items	Preparation & Handling
Prepare fresh weekly. Process two slides per jar. Process no more than 20 slides before replacing reagents. Alternatively, use a slide staining dish. Adjust volumes of deparaffinization solutions and water accordingly and ensure volume fully covers tissue.	
<input type="checkbox"/> Xylene	Label two Coplin jars as Xylene Jar 1 and 2. Dispense 30 ml xylene in each.
<input type="checkbox"/> 100% Ethanol	Label two Coplin jars as 100% Ethanol Jar 1 and 2. Dispense 30 ml 100% ethanol in each. Alternatively, use a 50-ml centrifuge tube or beaker.
<input type="checkbox"/> 96% Ethanol	Label two Coplin jars as 96% Ethanol Jar 1 and 2. Dispense 30 ml 96% ethanol in each. Alternatively, use a 50-ml centrifuge tube or beaker.
<input type="checkbox"/> 70% Ethanol	Label one Coplin jar as 70% Ethanol Jar. Dispense 30 ml 70% ethanol. Alternatively, use a 50-ml centrifuge tube or beaker.
<input type="checkbox"/> Milli-Q or UltraPure Water	Label one Coplin jar as WaterJar. Dispense 30 ml water. Alternatively, use a 50-ml centrifuge tube or beaker.



Use xylene-resistant dishes for immersion in xylene. Use xylene-resistant gloves or forceps for deparaffinization. Prepare fresh reagents every week.

For IF Staining

Items	Preparation & Handling																				
Obtain																					
<input type="checkbox"/> 1X PBS	Prepare one 50-ml centrifuge tube of 1X PBS for each tissue slide. If necessary, prepare 1X PBS from 10X stock using nuclease-free water.																				
<table border="1"> <thead> <tr> <th>1X PBS <i>1 slide = 1 Tissue Slide</i></th> <th>Stock</th> <th>Final</th> <th>1 Slide (ml)</th> <th>2 Slides (ml)</th> </tr> </thead> <tbody> <tr> <td>10X PBS</td> <td>10X</td> <td>1X</td> <td>5</td> <td>10</td> </tr> <tr> <td>Nuclease-free Water</td> <td>-</td> <td>-</td> <td>45</td> <td>90</td> </tr> <tr> <td>Total</td> <td>-</td> <td>-</td> <td>50</td> <td>100</td> </tr> </tbody> </table>		1X PBS <i>1 slide = 1 Tissue Slide</i>	Stock	Final	1 Slide (ml)	2 Slides (ml)	10X PBS	10X	1X	5	10	Nuclease-free Water	-	-	45	90	Total	-	-	50	100
1X PBS <i>1 slide = 1 Tissue Slide</i>	Stock	Final	1 Slide (ml)	2 Slides (ml)																	
10X PBS	10X	1X	5	10																	
Nuclease-free Water	-	-	45	90																	
Total	-	-	50	100																	
<input type="checkbox"/> 10X PBS	-																				
<input type="checkbox"/> 70% Ethanol	Optional, if performing TrueBlack Quenching. Prepare 1 ml of 70% Ethanol by diluting stock ethanol with nuclease-free water.																				

Items	Preparation & Handling
<input type="checkbox"/> Wash Buffer	Prepare Wash Buffer according to the appropriate table below, adding reagents in the order listed. Pipette mix 10x and centrifuge briefly. Maintain on ice.

If using a fluorophore conjugated primary antibody:

6.5 mm

6.5 mm Gaskets				
Wash Buffer	Stock	Final	1X (µl)	2X +10% (µl)
<i>1X = 1 Tissue Slide Cassette Gasket</i>				
PBS	10X	1X	60.0	132.0
Tween-20	10%	0.4%	24.0	52.8
Nuclease-free Water	-	-	516.0	1,135.2
Total	-	-	600.0	1,320.0

11 mm

11 mm Gaskets				
Wash Buffer	Stock	Final	1X (µl)	2X +10% (µl)
<i>1X = 1 Tissue Slide Cassette Gasket</i>				
PBS	10X	1X	120.0	264.0
Tween-20	10%	0.4%	48.0	105.6
Nuclease-free Water	-	-	1,032.0	2,270.4
Total	-	-	1,200	2,640.0

If using a primary and secondary antibody:

6.5 mm

6.5 mm Gaskets				
Wash Buffer	Stock	Final	1X (µl)	2X +10% (µl)
<i>1X = 1 Tissue Slide Cassette Gasket</i>				
PBS	10X	1X	120.0	264.0
Tween-20	10%	0.4%	48.0	105.6
Nuclease-free Water	-	-	1,032.0	2,270.4
Total	-	-	1,200.0	2,640.0

IF Staining & Imaging

Items Preparation & Handling



11 mm Gaskets				
Wash Buffer	Stock	Final	1X (µl)	2X +10% (µl)
<i>1X = 1 Tissue Slide Cassette Gasket</i>				
PBS	10X	1X	240.0	528.0
Tween-20	10%	0.4%	96.0	211.2
Nuclease-free Water	-	-	2,064.0	4,540.8
Total	-	-	2,400.0	5,280.0



1X Blocking Buffer

Prepare Blocking Buffer on ice according to the appropriate table below, adding reagents in the order listed. Pipette mix 10x and centrifuge briefly. Maintain on ice.





6.5 mm Gaskets				
1X Blocking Buffer	Stock	Final	1X (µl)	2X +10% (µl)
PBS	10X	1X	10.0	22.0
BSA	10%	2%	20.0	44.0
RNase Inhibitor	40X	1X	2.5	5.5
Tween-20	10%	0.1%	1.0	2.2
Nuclease-free Water	-	-	66.5	146.3
Total	-	-	100.0	220.0



11 mm Gaskets				
1X Blocking Buffer	Stock	Final	1X (µl)	2X +10% (µl)
PBS	10X	1X	20.0	44.0
BSA	10%	2%	40.0	88.0
RNase Inhibitor	40X	1X	5.0	11.0
Tween-20	10%	0.1%	2.0	4.4
Nuclease-free Water	-	-	133.0	292.6
Total	-	-	200.0	440.0

IF Staining & Imaging

For Decrosslinking

Items	10x PN	Preparation & Handling	Storage
Heat to 37°C			
<input type="checkbox"/> 	Decrosslinking Buffer B 2001094	Pre-heat thermomixer or water bath to 37°C. Thaw in a thermomixer (300 rpm with shaking) or water bath for 30 min at 37°C during Destaining.	-20°C
Equilibrate to room temperature			
<input type="checkbox"/> 	Perm Enzyme B 3000553	Remove from -20°C shortly before use. Maintain at room temperature. Pipette mix, centrifuge briefly. DO NOT vortex.	-20°C
<input type="checkbox"/> 	Decrosslinking Buffer B 2001094	After heating to 37°C as indicated above, cool to room temperature for 5 min. Vortex for 30 sec and centrifuge briefly.	-20°C
Obtain			
<input type="checkbox"/>	Nuclease-free Water -	-	Ambient
<input type="checkbox"/>	1X PBS -	Prepare 1 ml 1X PBS from 10X stock using nuclease-free water.	Ambient
<input type="checkbox"/>	8M Urea -	-	Ambient

For Coverslip Mounting

Items	Preparation & Handling																				
Prepare																					
<input type="checkbox"/> Mounting Medium	Prepare immediately before use. Invert to mix. Briefly centrifuge to remove bubbles. Inspect for bubbles. Continue centrifuging until no bubbles remain.																				
	<table border="1"> <thead> <tr> <th>Mounting Medium <i>1 slide = 1 Tissue Slide</i></th> <th>Stock</th> <th>Final</th> <th>1 Slide (μl)</th> <th>2 Slides +15% (μl)</th> </tr> </thead> <tbody> <tr> <td>Glycerol</td> <td>100%</td> <td>80%</td> <td>120</td> <td>276</td> </tr> <tr> <td>SlowFade Diamond</td> <td>100%</td> <td>20%</td> <td>30</td> <td>69</td> </tr> <tr> <td>Total</td> <td>-</td> <td>-</td> <td>150</td> <td>345</td> </tr> </tbody> </table>	Mounting Medium <i>1 slide = 1 Tissue Slide</i>	Stock	Final	1 Slide (μ l)	2 Slides +15% (μ l)	Glycerol	100%	80%	120	276	SlowFade Diamond	100%	20%	30	69	Total	-	-	150	345
Mounting Medium <i>1 slide = 1 Tissue Slide</i>	Stock	Final	1 Slide (μ l)	2 Slides +15% (μ l)																	
Glycerol	100%	80%	120	276																	
SlowFade Diamond	100%	20%	30	69																	
Total	-	-	150	345																	
Obtain																					
<input type="checkbox"/> Coverslip	-																				

For Coverslip Removal

Items	Preparation & Handling
Prepare fresh.	
<input type="checkbox"/> 1X PBS	Prepare 800 ml 1X PBS. If using 10X stock, prepare 1X PBS using nuclease-free water.

4.1 Protocol Overview

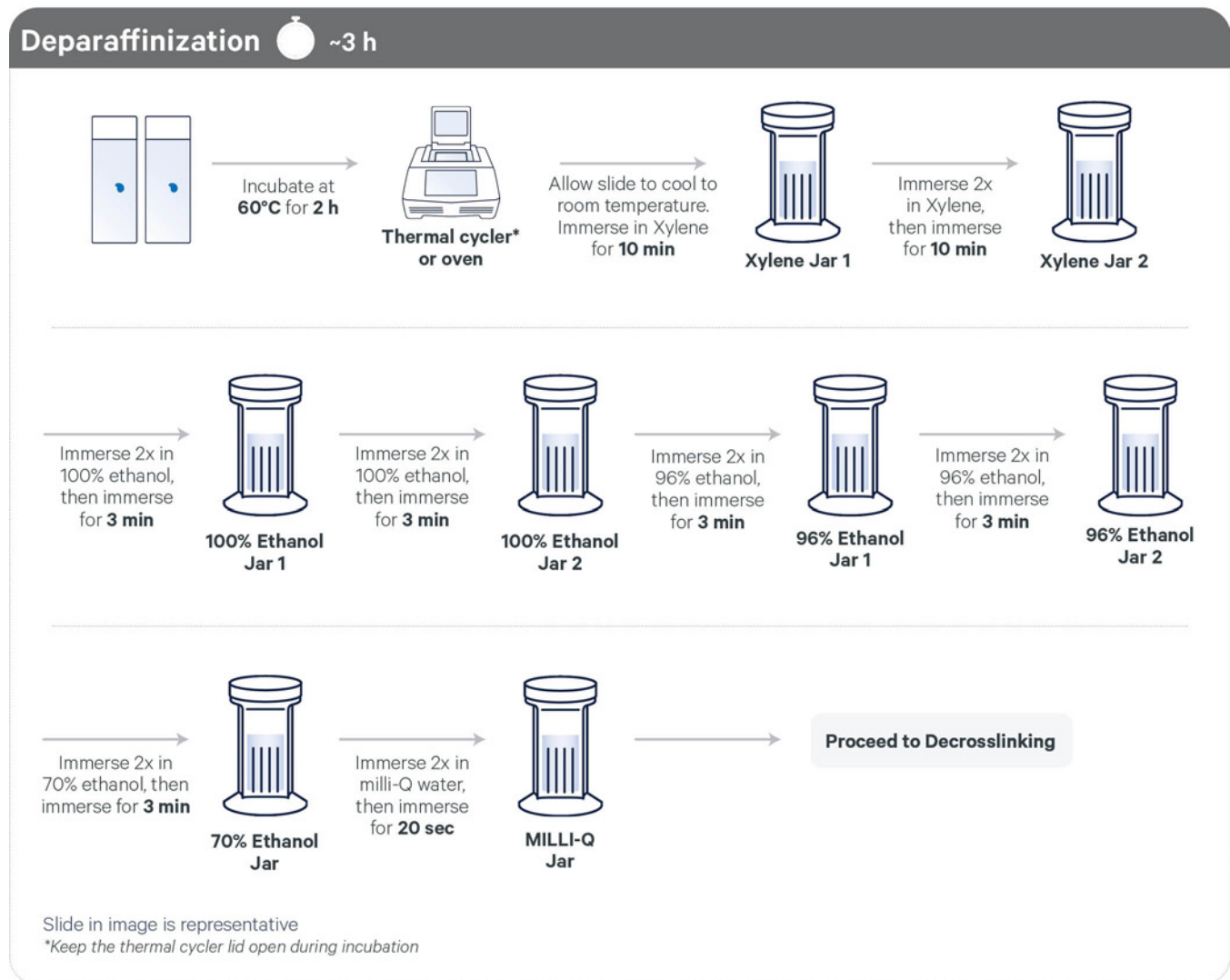

IF Staining & Imaging

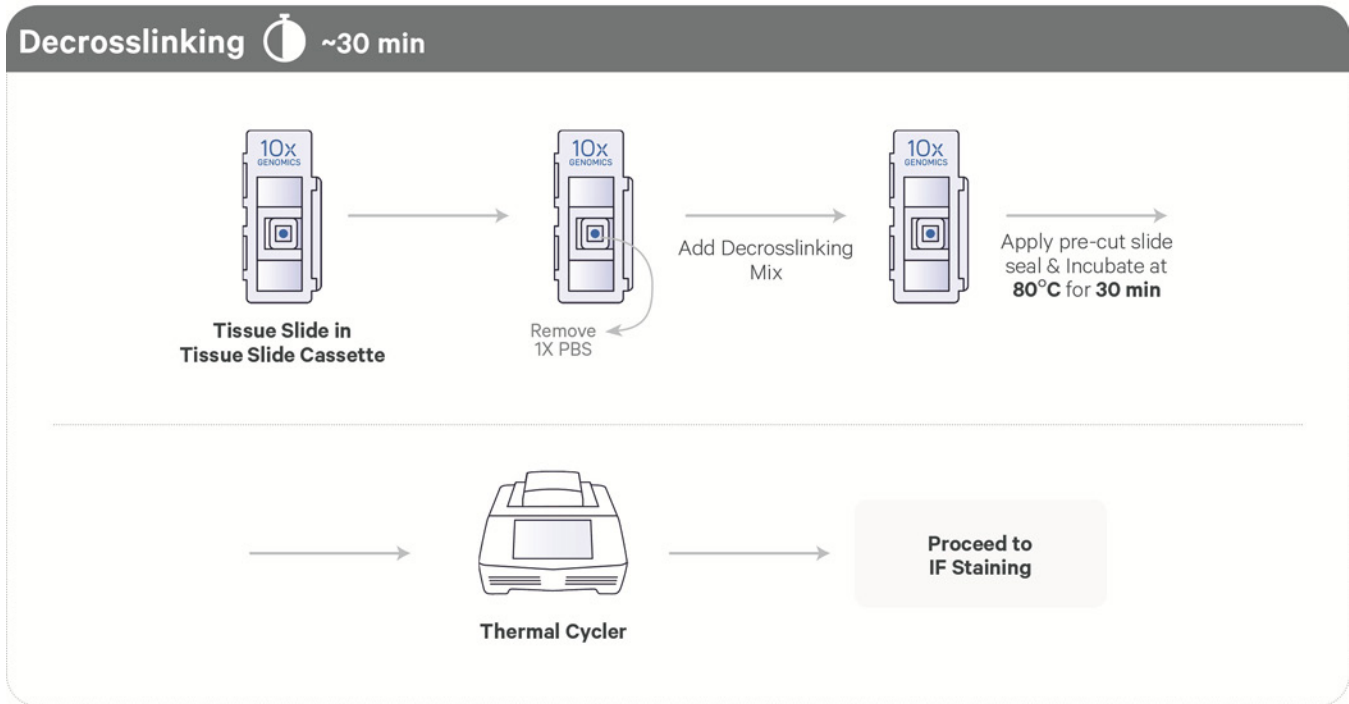

Immunofluorescence Staining – Fluorophore Conjugated Primary Antibodies ~2 h

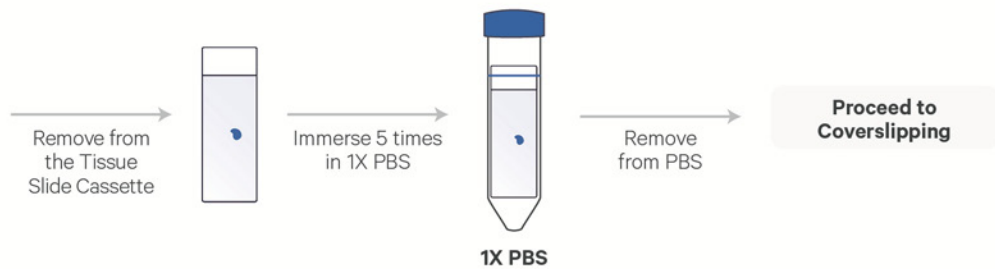
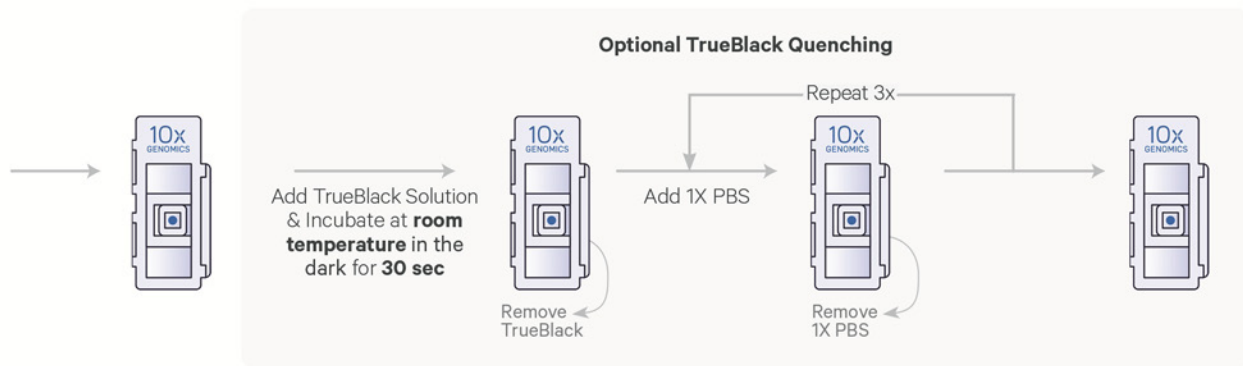
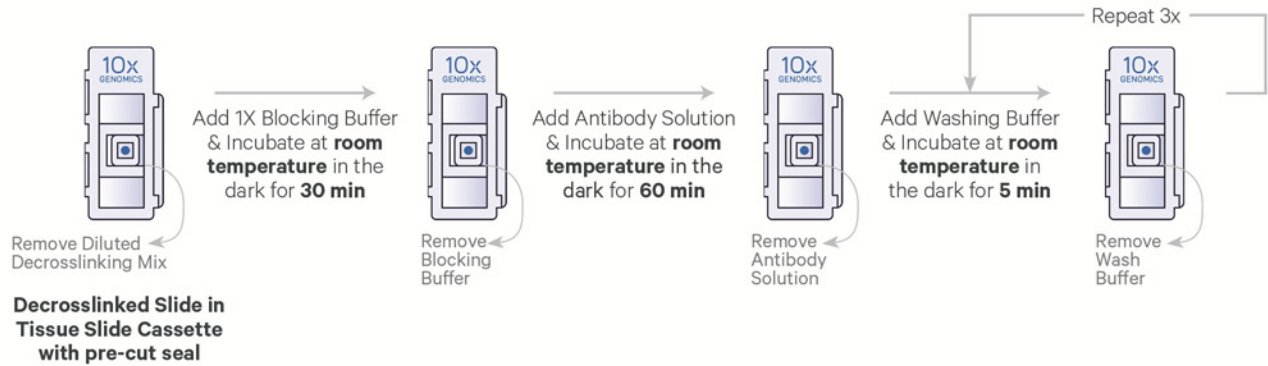

IF Staining & Imaging

Immunofluorescence Staining – Primary & Secondary Antibodies ~2.5 h

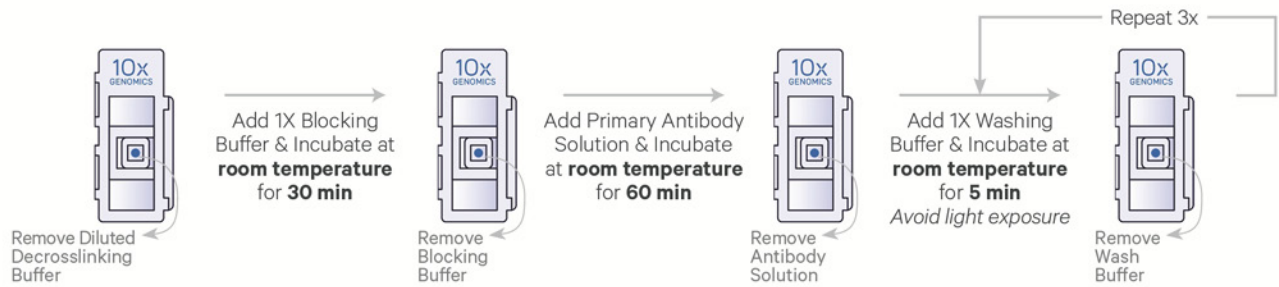

Decrosslinked slide in Tissue Slide Cassette with a pre-cut seal

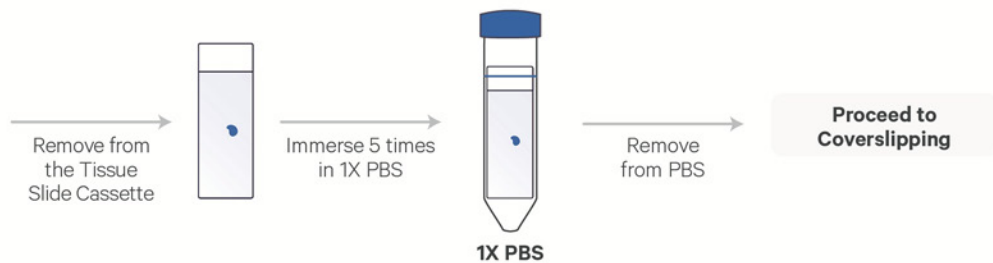
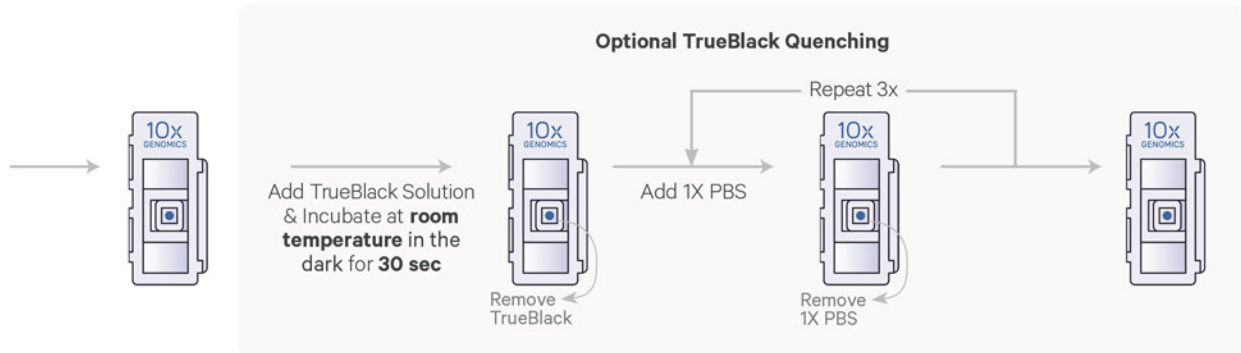
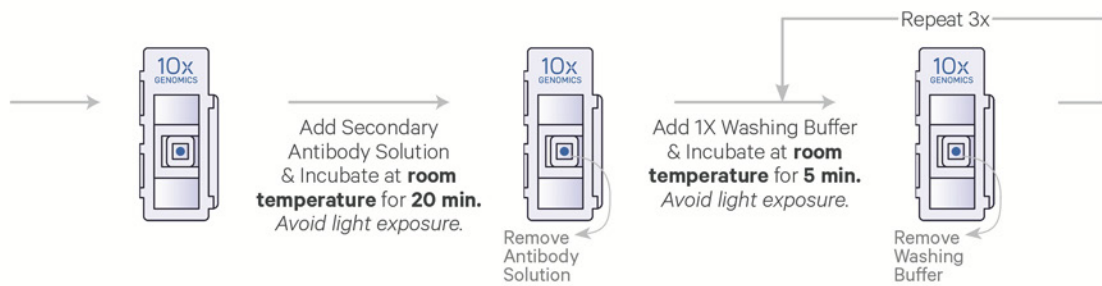

IF Staining & Imaging

4.2 Deparaffinization

Deparaffinization steps should be performed in a fume hood due to the hazardous nature of xylene. If slides were stored at 4°C, allow slides to come to room temperature prior to deparaffinization.

- a. Retrieve slides with tissue sections from desiccator after overnight drying.
- b. Place slides in a rack sideways in a Section Dryer Oven and incubate uncovered at **60°C** for **2 h**. Keep oven lid closed during incubation.

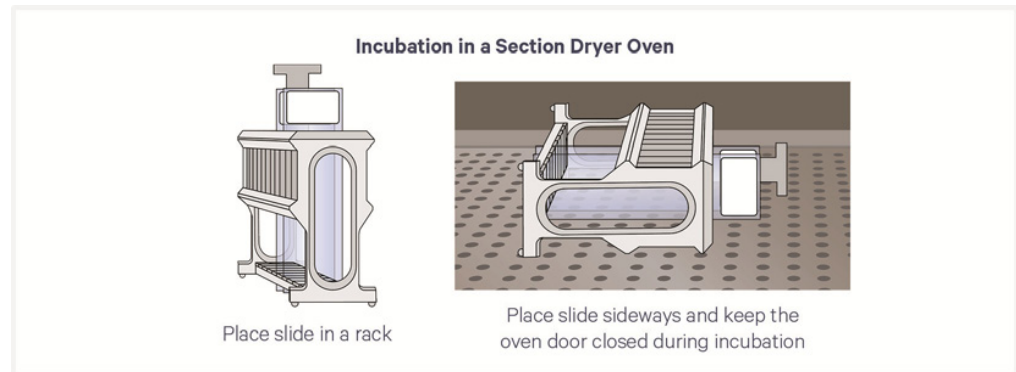

Alternatively, place a Low Profile Thermocycler Adapter on a thermal cycler set at **60°C**. Place slide on the Low Profile Thermocycler Adapter with the tissue side facing up and incubate **2 h** at **60°C**.



DO NOT close the thermal cycler lid.



- c. Remove slides from the oven or thermal cycler and allow to cool down to room temperature for **5 min**.



When immersing slides in xylene, ensure that the tissue sections are completely submerged.

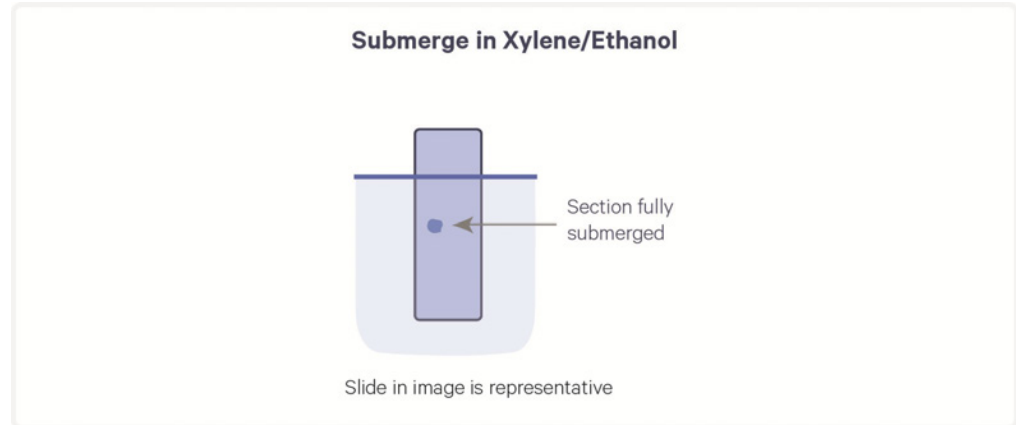

- d. Gently immerse slides 2x in Xylene Jar 1, then immerse and incubate for **10 min**. Secure jar cap to prevent xylene loss.
- e. Gently immerse slides 2x in Xylene Jar 2, then immerse and incubate for **10 min**. Secure jar cap to prevent xylene loss.
- f. Gently immerse slides 2x in 100% Ethanol Jar 1, then immerse and incubate for **3 min**.
- g. Gently immerse slides 2x in 100% Ethanol Jar 2, then immerse and incubate for **3 min**.
- h. Gently immerse slides 2x in 96% Ethanol Jar 1, then immerse and incubate for **3 min**.
- i. Gently immerse slides 2x in 96% Ethanol Jar 2, then immerse and incubate for **3 min**.
- j. Gently immerse slides 2x in 70% Ethanol Jar, then immerse and incubate for **3 min**.
- k. Gently immerse slides 2x in Water Jar, then immerse and incubate for **20 sec**.
- l. Allow slides to air dry and proceed to Decrosslinking.

4.3 Decrosslinking

■ denotes volumes for 6.5 mm gaskets and ▲ denotes volumes for 11 mm gaskets.



Ensure Decrosslinking Buffer B has been prepared according to [Get Started on page 81](#).

- a. Prepare thermal cycler with the following incubation protocol.

Lid Temperature	Reaction Volume	Run Time
80°C	100 µl	40 min
Step	Temperature	Time hh:mm:ss
Hold	22°C	Hold
Decrosslinking	80°C	00:30:00
Re-equilibrate	22°C	00:10:00
Hold	22°C	Hold



- b. Prepare Diluted Perm Enzyme B according to the table below. Add reagents in the order listed. Mix thoroughly with a P20 pipette set to 17 µl. Maintain at room temperature.

Diluted Perm Enzyme B	Stock	Final	10x PN	Total Amount (µl)
1X PBS	-	-	-	16.8
● Perm Enzyme B (Maintain at room temperature. Pipette mix, centrifuge briefly. DO NOT vortex).	-	-	3000553	3.2
Total	-	-	-	20.0

- c. Prepare Decrosslinking Mix according to the appropriate table below. Add reagents in the order listed. Pipette mix thoroughly. Centrifuge briefly. Maintain at room temperature.

6.5 mm

6.5 mm Gaskets						
Decrosslinking Mix 1 slide = 1 Tissue Slide		Stock	Final	1 slide (μ l)	2 slides + 10% (μ l)	4 slides + 10% (μ l)
●	Decrosslinking Buffer B	-	-	92.4	203.4	407.0
	Urea	8 M	0.5 M	6.3	13.8	27.5
	Diluted Perm Enzyme B (prepared in step b)	-	-	1.3	2.8	5.5
	Total	-	-	100.0	220.0	440.0

11 mm

11 mm Gaskets						
Decrosslinking Mix 1 slide = 1 Tissue Slide		Stock	Final	1 slide (μ l)	2 slides + 10% (μ l)	4 slides + 10% (μ l)
●	Decrosslinking Buffer B	-	-	184.8	407	813.1
	Urea	8 M	0.5 M	12.6	27.5	55.4
	Diluted Perm Enzyme B (prepared in step b)	-	-	2.6	5.5	11.4
	Total	-	-	200.0	440.0	880.0

- d. Place slide in a Tissue Slide Cassette.

See Visium Cassette S3 Quick Reference Card (CG000730) for assembly instructions. Practice assembly with a blank slide.

- e. Add ■ **100 μ l** or ▲ **200 μ l** 1X PBS along the side of the wells.
- f. Remove 1X PBS from wells.
- g. Add ■ **100 μ l** or ▲ **200 μ l** Decrosslinking Mix along the side of the wells
- TIPS** h. Apply a new pre-cut slide seal on the cassette and place cassette on Low Profile Thermocycler Adapter. See Tips & Best Practices for more information on cassette incubation in a thermal cycler.
- i. Close and tighten thermal cycler lid. Skip Pre-equilibrate step and initiate Decrosslinking.
- j. After decrosslinking is complete, remove cassette from Low Profile Thermocycler Adapter and place on a flat, clean work surface.

- k.** Peel back slide seal and using a pipette, remove all Decrosslinking Mix from well corners.
- l.** Add ■ **150 µl** or ▲ **300 µl** 1X PBS along the side of the wells to uniformly cover tissue sections, without introducing bubbles.
- m.** Proceed **immediately** to appropriate Immunofluorescence Staining protocol.

4.4 Immunofluorescence Staining



Choose appropriate staining protocol depending upon the type of antibodies used. If using a primary and secondary antibody, proceed directly to [Immunofluorescence Staining - Primary & Secondary Antibodies on page 98](#).



Antibody dilution may vary depending on the antibody, ranging from 1:50 down to 1:1000. Antibody volumes will depend on concentrations determined during antibody optimization.

4.5 Immunofluorescence Staining - Fluorophore Conjugated Primary Antibodies

- a. Prepare Antibody Solution on ice, adding reagents in the order listed. Pipette mix 10x and centrifuge briefly. Maintain on ice.

6.5 mm

6.5 mm Gaskets					
Antibody Solution	Stock	Final	1X (µl)	2X +10% (µl)	4X +10% (µl)
<i>1X = 1 Tissue Slide Cassette Gasket</i>					
PBS	10X	1X	7.0	15.4	30.8
BSA	10%	2%	14.0	30.8	61.6
RNase Inhibitor	40X	2X	3.5	7.7	15.4
Tween-20	10%	0.1%	0.7	1.5	3.1
Antibody #1	Variable	Variable	Variable	Variable	Variable
Antibody #2 (Optional)	Variable	Variable	Variable	Variable	Variable
Antibody #3 (Optional)	Variable	Variable	Variable	Variable	Variable
DAPI Solution	100X	0.5X	0.4	0.8	1.5
Nuclease-free Water	Variable	Variable	Variable	Variable	Variable
Total	-	-	70.0	154.0	308.0



11 mm Gaskets					
Antibody Solution	Stock	Final	1X (µl)	2X +10% (µl)	4X +10% (µl)
PBS	10X	1X	14.0	30.8	61.6
BSA	10%	2%	28.0	61.6	123.2
RNase Inhibitor	40UX	2X	7.0	15.4	30.8
Antibody #1	Variable	Variable	Variable	Variable	Variable
Antibody #2 (Optional)	Variable	Variable	Variable	Variable	Variable
Antibody #3 (Optional)	Variable	Variable	Variable	Variable	Variable
DAPI Solution	100X	1X	1.4	3.1	6.2
Nuclease-free Water	Variable	Variable	Variable	Variable	Variable
Total	-	-	140.0	308.0	616.0

- b. *Optional* - Prepare 1X TrueBlack Solution according to the appropriate table, adding reagents in the order listed. Pipette mix 10x and centrifuge briefly. Maintain at room temperature.



6.5 mm Gaskets					
1X TrueBlack Solution	Stock	Final	1X (µl)	2X +10% (µl)	4X +10% (µl)
<i>1X = 1 Tissue Slide Cassette Gasket</i>					
TrueBlack Lipofuscin Quencher	20X	1X	3.5	7.7	15.4
70% Ethanol	-	-	66.5	146.3	292.6
Total	-	-	70.0	154.0	308.0



11 mm Gaskets					
1X	Stock	Final	1X (µl)	2X +10% (µl)	4X +10% (µl)
TrueBlack Lipofuscin Quencher	20X	1X	7.0	15.4	30.8
70% Ethanol	-	-	133.0	292.6	585.2
Total	-	-	140.0	308.0	616.0

IF Staining & Imaging

- c. Peel back slide seal and remove all 1X PBS from wells.
- d. Add ■ **100 µl** or ▲ **200 µl** 1X Blocking Buffer along the side of the wells.
- e. Re-apply Visium Slide Seal to Tissue Slide Cassette.
- f. Incubate for **30 min** at **room temperature**.
- g. Peel back slide seal and remove all Blocking Buffer from wells.
- h. Add ■ **70 µl** or ▲ **140 µl** Antibody Solution along the side of the wells. Tap gently to ensure uniform coverage.
- i. Re-apply slide seal to cassette.
- j. Incubate for **1 h** at **room temperature** in the dark.
- k. Peel back slide seal and remove Antibody Solution.

Four Wash Buffer washes:

- l. **Wash 1:** Add ■ **150 µl** or ▲ **300 µl** Wash Buffer along the side of the wells. Incubate for **5 min** at **room temperature**. Remove all Wash Buffer from wells.
- m. **Wash 2:** Add ■ **150 µl** or ▲ **300 µl** Wash Buffer along the side of the wells. Incubate for **5 min** at **room temperature**. Remove all Wash Buffer from wells.
- n. **Wash 3:** Add ■ **150 µl** or ▲ **300 µl** Wash Buffer along the side of the wells. Incubate for **5 min** at **room temperature**. Remove all Wash Buffer from wells.
- o. **Wash 4:** Add ■ **150 µl** or ▲ **300 µl** Wash Buffer along the side of the wells. Incubate for **5 min** at **room temperature**. Remove all Wash Buffer from wells.
- p. *Optional* - TrueBlack Quenching
 - Add ■ **70 µl** or ▲ **140 µl** 1X TrueBlack Solution along the side of the wells. Tap cassette gently to ensure uniform coverage.
 - Incubate for **30 sec** at **room temperature**.
 - Remove all 1X TrueBlack Solution from wells.

Four PBS washes:

- **Wash 1:** Add ■ **150 µl** or ▲ **300 µl** 1X PBS along the side of the wells. Remove all PBS from wells.
- **Wash 2:** Add ■ **150 µl** or ▲ **300 µl** 1X PBS along the side of the wells. Remove all PBS from wells.
- **Wash 3:** Add ■ **150 µl** or ▲ **300 µl** 1X PBS along the side of the wells. Remove all PBS from wells.
- **Wash 4:** Add ■ **150 µl** or ▲ **300 µl** 1X PBS along the side of the wells. Remove all PBS from wells.

q. Remove slide from cassette.



See Tips & Best Practices for removal instructions.

- r. Gently immerse slide 5x in 1X PBS in 50-ml centrifuge tube. If processing multiple slides, use a separate 50-ml centrifuge tube filled with PBS for each slide.
- s. Remove slide from PBS and proceed **immediately** to Coverslip Mounting.



DO NOT let the slide dry.

4.6 Immunofluorescence Staining - Primary & Secondary Antibodies

- a. Prepare Primary Antibody Solution on ice, adding reagents in the order listed. Pipette mix 10x and centrifuge briefly. Maintain on ice.

6.5 mm

6.5 mm Gaskets					
Primary Antibody Solution	Stock	Final	1X (µl)	2X +10% (µl)	4X +10% (µl)
<i>1X = 1 Tissue Slide Cassette Gasket</i>					
PBS	10X	1X	7.0	15.4	30.8
BSA	10%	2%	14.0	30.8	61.6
RNase Inhibitor	40X	2X	3.5	7.7	15.4
Tween-20	10%	0.1%	0.7	1.5	3.1
Antibody #1	Variable	Variable	Variable	Variable	Variable
Antibody #2 (Optional)	Variable	Variable	Variable	Variable	Variable
Antibody #3 (Optional)	Variable	Variable	Variable	Variable	Variable
Nuclease-free Water	Variable	Variable	Variable	Variable	Variable
Total	-	-	70.0	154.0	308.0

11 mm

11 mm Gaskets					
Primary Antibody Solution	Stock	Final	1X (µl)	2X +10% (µl)	4X +10% (µl)
PBS	10X	1X	14.0	30.8	61.6
BSA	10%	2%	28.0	61.6	123.2
RNase Inhibitor	40X	2X	7.0	15.4	30.8
Antibody #1	Variable	Variable	Variable	Variable	Variable
Antibody #2 (Optional)	Variable	Variable	Variable	Variable	Variable
Antibody #3 (Optional)	Variable	Variable	Variable	Variable	Variable
Nuclease-free Water	Variable	Variable	Variable	Variable	Variable
Total	-	-	140.0	308.0	616.0

- b. Prepare Secondary Antibody Solution on ice, adding reagents in the order listed. Pipette mix 10x and centrifuge briefly. Maintain on ice.

6.5 mm

6.5 mm Gaskets					
Secondary Antibody Solution	Stock	Final	1X (µl)	2X +10% (µl)	4X +10% (µl)
<i>1X = 1 Tissue Slide Cassette Gasket</i>					
PBS	10X	1X	7.0	15.4	30.8
BSA	10%	2%	14.0	30.8	61.6
RNase Inhibitor	40X	2X	3.5	7.7	15.4
Tween-20	10%	0.1%	0.7	1.5	3.1
Antibody #1	Variable	Variable	Variable	Variable	Variable
Antibody #2 (Optional)	Variable	Variable	Variable	Variable	Variable
Antibody #3 (Optional)	Variable	Variable	Variable	Variable	Variable
DAPI Solution	100X	1X	0.7	1.5	3.1
Nuclease-free Water	Variable	Variable	Variable	Variable	Variable
Total	-	-	70.0	154.0	308.0

11 mm

11 mm Gaskets					
Secondary Antibody Solution	Stock	Final	1X (µl)	2X +10% (µl)	4X +10% (µl)
PBS	10X	1X	14.0	30.8	61.6
BSA	10%	2%	28.0	61.6	123.2
RNase Inhibitor	40X	2X	7.0	15.4	30.8
Antibody #1	Variable	Variable	Variable	Variable	Variable
Antibody #2 (Optional)	Variable	Variable	Variable	Variable	Variable
Antibody #3 (Optional)	Variable	Variable	Variable	Variable	Variable
DAPI Solution	100X	1X	1.4	3.1	6.2
Nuclease-free Water	Variable	Variable	Variable	Variable	Variable
Total	-	-	140.0	308.0	616.0

TIPS

Antibody dilution can change depending on the antibody, ranging from 1:10 up to 1:1500. Antibody volumes will depend on concentrations determined during antibody optimization.

IF Staining & Imaging

- c. *Optional* - Prepare 1X TrueBlack Solution according to the appropriate table, adding reagents in the order listed. Pipette mix 10x and centrifuge briefly. Maintain at room temperature.

6.5 mm

6.5 mm Gaskets					
1X TrueBlack Solution	Stock	Final	1X (µl)	2X +10% (µl)	4X +10% (µl)
<i>1X = 1 Tissue Slide Cassette Gasket</i>					
TrueBlack Lipofuscin Quencher	20X	1X	3.5	7.7	15.4
70% Ethanol	-	-	66.5	146.3	292.6
Total	-	-	70.0	154.0	308.0

11 mm

11 mm Gaskets					
1X	Stock	Final	1X (µl)	2X +10% (µl)	4X +10% (µl)
TrueBlack Lipofuscin Quencher	20X	1X	7.0	15.4	30.8
70% Ethanol	-	-	133.0	292.6	585.2
Total	-	-	140.0	308.0	616.0

- d. Peel back slide seal and remove all 1X PBS from wells.
- e. Add ■ **100 µl** or ▲ **200 µl** 1X Blocking Buffer along the side of the wells.
- f. Re-apply Visium Slide Seal to Tissue Slide Cassette.
- g. Incubate for **30 min** at **room temperature**.
- h. Peel back slide seal and remove all Blocking Buffer from wells.
- i. Add ■ **70 µl** or ▲ **140 µl** Primary Antibody Solution along the side of the wells. Tap gently to ensure uniform coverage.
- j. Re-apply slide seal to cassette.
- k. Incubate for **1 h** at **room temperature** in the dark.
- l. Peel back slide seal and remove Primary Antibody Solution.
- Four Wash Buffer washes:**
- m. **Wash 1:** Add ■ **150 µl** or ▲ **300 µl** Wash Buffer along the side of the wells. Incubate for **5 min** at **room temperature**. Remove all Wash Buffer from

wells.

- n. **Wash 2:** Add ■ **150 µl** or ▲ **300 µl** Wash Buffer along the side of the wells. Incubate for **5 min** at **room temperature**. Remove all Wash Buffer from wells.
- o. **Wash 3:** Add ■ **150 µl** or ▲ **300 µl** Wash Buffer along the side of the wells. Incubate for **5 min** at **room temperature**. Remove all Wash Buffer from wells.
- p. **Wash 4:** Add ■ **150 µl** or ▲ **300 µl** Wash Buffer along the side of the wells. Incubate for **5 min** at **room temperature**. Remove all Wash Buffer from wells.
- q. Add ■ **70 µl** or ▲ **140 µl** Secondary Antibody Solution along the side of the wells. Tap gently to ensure uniform coverage.
- r. Re-apply slide seal to cassette.
- s. Incubate for **20 min** at **room temperature** in the dark.
- t. Peel back slide seal and remove Secondary Antibody Solution.

Four Wash Buffer washes:

- u. **Wash 1:** Add ■ **150 µl** or ▲ **300 µl** Wash Buffer along the side of the wells. Incubate for **5 min** at **room temperature**. Remove all Wash Buffer from wells.
- v. **Wash 2:** Add ■ **150 µl** or ▲ **300 µl** Wash Buffer along the side of the wells. Incubate for **5 min** at **room temperature**. Remove all Wash Buffer from wells.
- w. **Wash 3:** Add ■ **150 µl** or ▲ **300 µl** Wash Buffer along the side of the wells. Incubate for **5 min** at **room temperature**. Remove all Wash Buffer from wells.
- x. **Wash 4:** Add ■ **150 µl** or ▲ **300 µl** Wash Buffer along the side of the wells. Incubate for **5 min** at **room temperature**. Remove all Wash Buffer from wells.
- y. *Optional* - TrueBlack Quenching
 - Add ■ **70 µl** or ▲ **140 µl** 1X TrueBlack Solution along the side of the wells. Tap cassette gently to ensure uniform coverage.
 - Incubate for **30 sec** at **room temperature**.
 - Remove all 1X TrueBlack Solution from wells.

Four PBS washes:

- **Wash 1:** Add ■ 150 µl or ▲ 300 µl 1X PBS along the side of the wells. Remove all PBS from wells.
 - **Wash 2:** Add ■ 150 µl or ▲ 300 µl 1X PBS along the side of the wells. Remove all PBS from wells.
 - **Wash 3:** Add ■ 150 µl or ▲ 300 µl 1X PBS along the side of the wells. Remove all PBS from wells.
 - **Wash 4:** Add ■ 150 µl or ▲ 300 µl 1X PBS along the side of the wells. Remove all PBS from wells.
- z. Remove slide from cassette.



See Tips & Best Practices for removal instructions.

- aa. Gently immerse slide 5x in 1X PBS in a 50-ml centrifuge tube. If processing multiple slides, use a separate 50-ml centrifuge tube filled with PBS for each slide.
- ab. Remove slide from PBS and proceed **immediately** to Coverslip Mounting.



DO NOT let the slide dry.

4.7 Coverslip Mounting

- a. Place slides on a flat, clean, nonabsorbent work surface. Some residual droplets may remain.
- b. Using a **wide-bore** pipette tip, add **100–150 μ l** Mounting Medium to cover all tissue sections uniformly.

Tissue slides with large sections or multiple sections may require more Mounting Medium.

- c. Slowly apply coverslip at an angle on one end of the slides, without introducing bubbles. Allow Mounting Medium to spread and settle.



DO NOT use Cytoseal or nail polish for securing the coverslip.

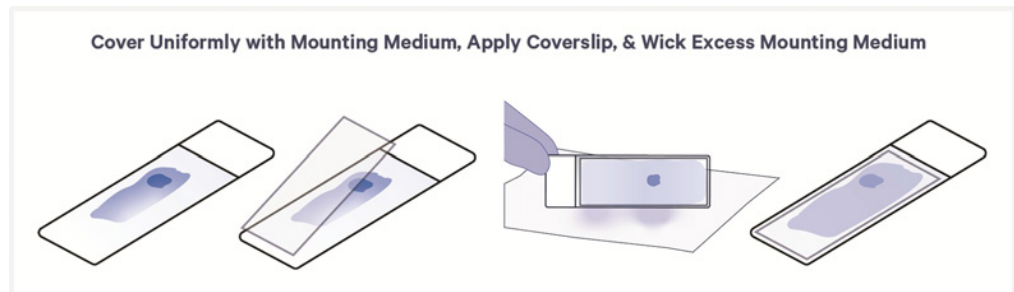

- d. Remove any large excess of Mounting Medium by carefully wicking away from the edge of the coverslip using a lint-free laboratory wipe. Do not move coverslip and disturb tissue.



- e. **Immediately** proceed with imaging or store slides laying flat in a slide mailer or a slide holder. Store slides at **4°C** for up to **24 h**. Ensure that slides are laid flat to prevent loss of Mounting Medium.

If storing slides for longer is desired, **immediately** proceed with imaging and follow stop instructions in [Coverslip Removal on the next page](#). The stopping point above and the stopping point in [Coverslip Removal on the next page](#) cannot be combined.



Coverslip will dry out over time. DO NOT let the attached coverslip dry out.

4.8 Imaging

- a. Image tissue section of interest at desired magnification using fluorescence imaging settings. Consult the Visium HD Spatial Applications Imaging Guidelines Technical Note (CG000688) for additional information.

- b. If using the Visium CytAssist Alignment Aid to annotate the square window, do now so while the tissue slide is coverslipped. This annotation assists in gasket placement during cassette assembly. For more information, consult [Visium CytAssist Alignment Aid on page 22](#).
- c. Proceed **immediately** to Coverslip Removal.

4.9 Coverslip Removal

- a. Dispense **800 ml** 1X PBS in a beaker. Up to 10 slides may be processed using this beaker.
- b. Immerse slides sideways in the beaker containing **800 ml** 1X PBS with coverslipped surface fully sideways to prevent coverslip from dragging across tissue.
- c. Hold slides in PBS until the coverslip slowly separates away from slide.



To avoid tissue section damage or detachment, DO NOT move slide up and down, shake forcibly, or manually move coverslip.

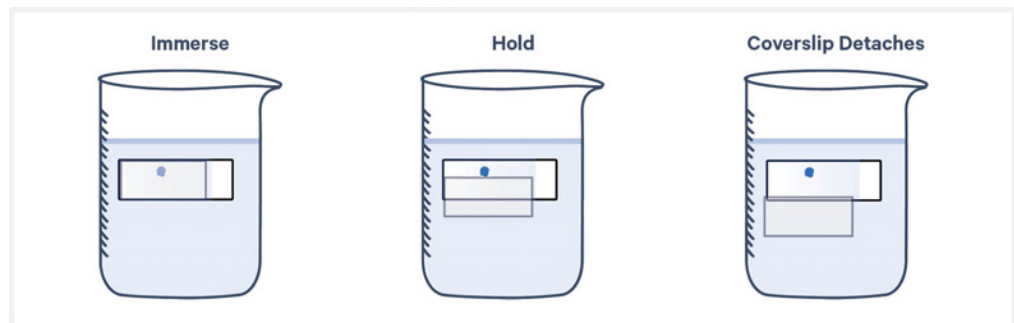

- d. Gently immerse slides **30x** in 1X PBS to ensure all Mounting Medium is removed.
- e. Wipe back of slide with a lint-free laboratory wipe.
- f. Place slide on a flat, clean, nonabsorbent work surface and air dry for **5 min**.
- g. Proceed **immediately** to step h or store slides laying flat in a slide mailer or slide holder at **4°C** in the dark with desiccant for up to **2 weeks**. Ensure slides do not touch one another and that desiccant does not come in contact with tissue slide.
- h. Place slide in a new Tissue Slide Cassette.
- i. Add **100 µl** or **200 µl** 1X PBS along the side of the wells.
- j. Apply a new pre-cut slide seal to cassette.



- k.** If the alignment aid was used to annotate the square window, remove the marks with a lint-free laboratory wipe and 70% isopropanol or 70% ethanol.
- l.** Proceed immediately to Visium HD Spatial Gene Expression Reagent Kits 2.0 User Guide (CG001679).

Troubleshooting

Ideal Floating Time Determination

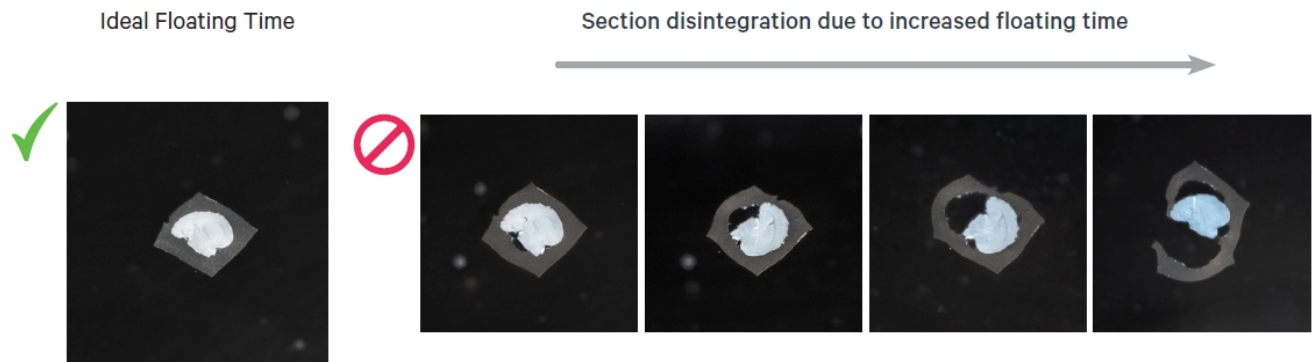

Incorrect Placement of Tissue Sections

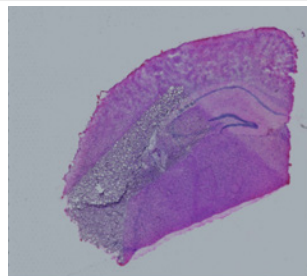

Folded tissue section

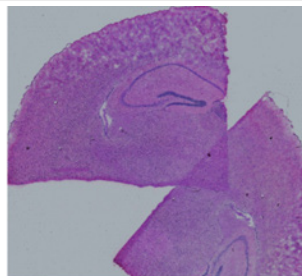

Overlapping sections

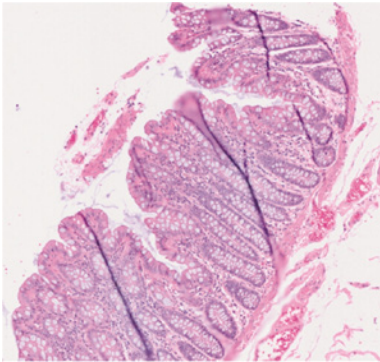
Common Artifacts that cause Detachment**Wrinkles****Causes**

- Section compression (due to warm block or dull blade) during sectioning leads to wrinkle formation. These wrinkles become permanent when placed in the water bath.
- Accumulated wax or static electricity on microtome parts also contribute to section compression.

Troubleshooting

- Ensure that the block is well hydrated.
- Adjust temperature down and increase float time.
- Gently and gradually lay FFPE sections onto water bath surface, lengthwise.
- Utilize a new blade.
- Ensure microtome is cleaned with 100% ethanol to minimize static and section compression (bunching on blade).

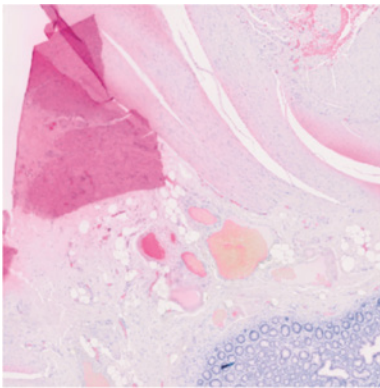
Folds**Causes**

- Mostly happens when placing the section on the water bath especially when the section is uneven.
- If the fold is at the edge this most likely can happen during sectioning or mounting on the slide.

Troubleshooting

- Gently and gradually lay FFPE ribbons or sections onto water bath surface, lengthwise.
- If sections curl during sectioning, gently flatten them with a brush before floating.

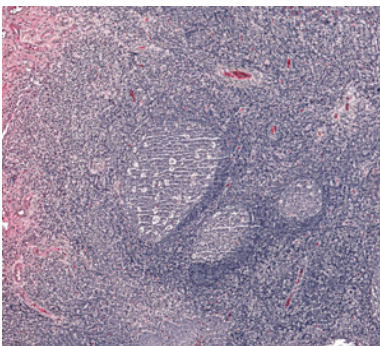
Venetian Blinds or Shatter**Causes**

- Parallel lines in the section mostly appear due to dry tissue because of under- hydration of the block in the ice bath.
- Less likely due to dull blade or loose parts of the microtome.

Troubleshooting

- Increase incubation time of the block in an ice bath.
- Tighten down components of microtome and make sure the blade is at a correct angle.

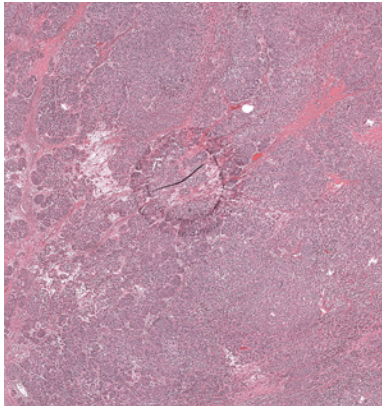
Common Artifacts that cause Detachment**Air Bubbles****Causes**

- Air bubbles from the bottom of the water bath can rise and stick under the section.

Troubleshooting

- Using a brush, gently remove the bubbles from the bottom of the water bath before floating the sections.

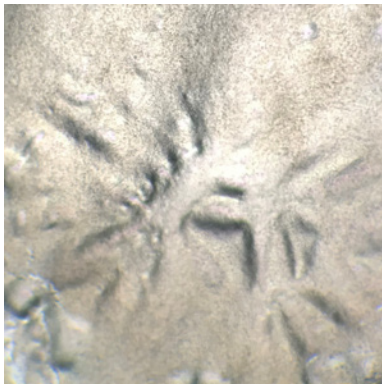
Waves

May be block-specific and easily observed under the microscope right after the section is picked up from the water bath. Minor waves can disappear after longer flotation in the water bath. Larger waves can create wrinkles or folds that are permanent after drying of the section.

Causes

- Tissue incompletely infiltrated with wax absorbs water faster during the hydration step. When sections from such blocks are floated, the parts that absorbed enough water will have difficulty flattening and become wavy.

Troubleshooting

- Chill the block on a cold block or on ice avoiding contact with water.
- Submerge the block for 5–15 min in the ice bath for gentle hydration.
- Increase flotation time and/or temperature of the water bath.

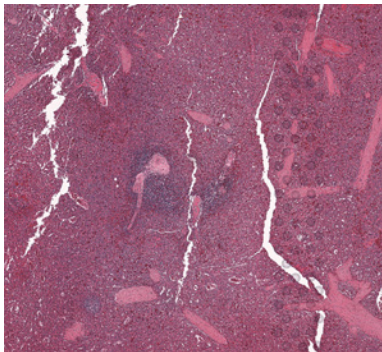
Cracks**Causes**

- Dry and overprocessed tissue can crack during sectioning.
- The cracks that are created before tissue embedding will be filled with wax when section is observed under the microscope after sectioning and wax will be washed away after deparaffinization or H&E staining.

Troubleshooting

- Prolonged hydration on the ice bath will most likely reduce the cracks.
- There is no solution for cracks created before tissue was embedded in wax.

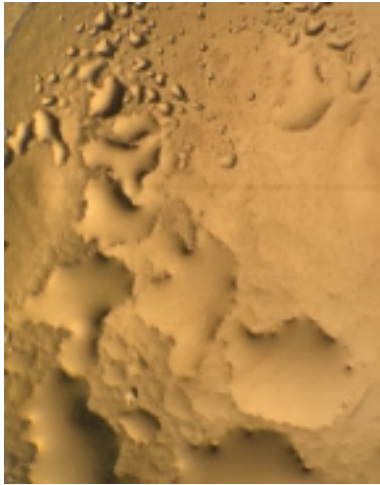
Common Artifacts that cause Detachment**Sweating****Causes**

- Inadequate dehydration or underprocessing of the tissue causes parts of the section to attract water and create this blistering effect. Such sections can disintegrate in the water bath.
- The blisters consist of:
 - Xylene or xylene substitutes if the cause is underprocessing and insufficient removal of xylene or
 - Water droplets if the cause is inadequate dehydration.

Troubleshooting

- Be cautious about how long the block is kept in an ice bath. Long incubation time in an ice bath can impact section quality and thus should be avoided.
- Long flotation time in the water bath should be avoided.

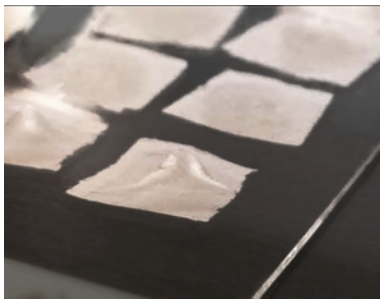
Water Retention**Causes**

- Sections from tissues that are underprocessed or excessively hydrated before sectioning may retain water under the section mounted on a slide.
- Water will accumulate under section and cause uneven drying ultimately leading to detachment.

Troubleshooting

- Gently flicking the slide will help to get rid of the water. This is one of the most overlooked cause of detachment.
- Use a fan to assist in drying.

Disintegrating/Exploding Section**Causes**

- Sections from tissues that are underprocessed and not sufficiently infiltrated with wax can rapidly absorb water and explode or gradually disintegrate in the water bath.
- Tissues that are not sufficiently dehydrated can show similar phenotypes.
- Floating at high temperatures (42-50°C) can exacerbate the disintegration.

Troubleshooting

- Chilling of the block should be mostly performed on ice or cold block (30–60 min).
- Exposure to water in an ice bath during chilling should be kept to a minimum (5–10 min).
- Flotation water bath temperature should be lowered to 38-40°C.

H&E Staining Troubleshooting**Bubbles**

Avoid bubble formation during coverslip mounting. Bubbles can be mitigated by applying the coverslip at an angle and slowly lowering it onto the slide, allowing air to escape. Centrifuge mounting medium to remove bubbles before use. Avoid introducing bubbles when pipetting mounting medium onto slide.

Bubbles may cause blackening of tissue.

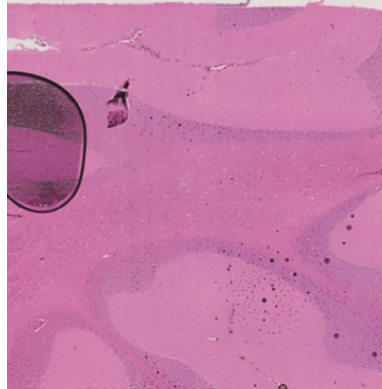
**Uneven Staining****Causes**

Ensure fresh, unexpired staining reagents are applied to the tissue uniformly and adequate washes are performed. A gentle tap may help reagents spread uniformly. Consider filtering hematoxylin.

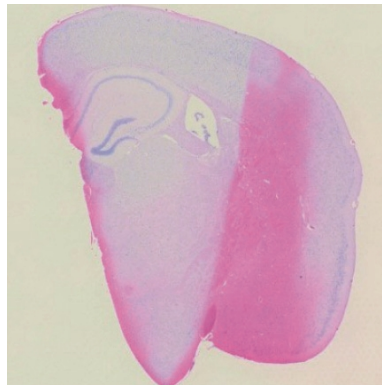

Uneven staining may also be caused by allowing slides to dry during staining. Ensure that slides do not air dry prior to coverslip mounting.

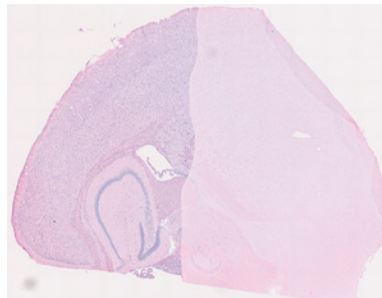

H&E Staining Troubleshooting**Incorrect Staining Protocol**

The staining protocol in this handbook was optimized for tissues that will be processed with the Visium HD assay. Using an alternative H&E staining protocol may result in reduced staining performance.

In the mouse embryo examples below, the Visium HD H&E protocol results in better contrast between the hematoxylin (blue) stained nuclei and the eosin (pink) stained cytoplasm compared to the incorrect protocol.

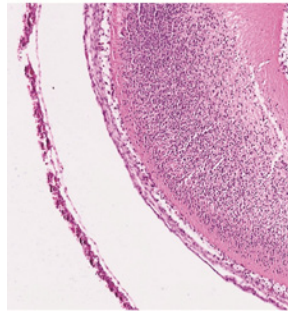
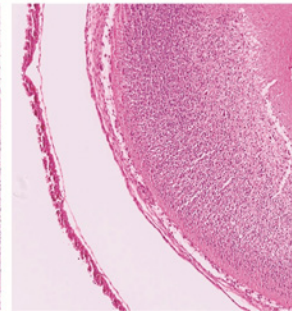
Visium HD H&E Protocol**Incorrect Protocol****Particulate Matter in H&E Staining**

If particulate matter is seen after H&E staining, warm the hematoxylin solution at 37°C for 10-15 min, mix, cool and filter through filter paper with pore size between 8-11 μm before performing additional staining.

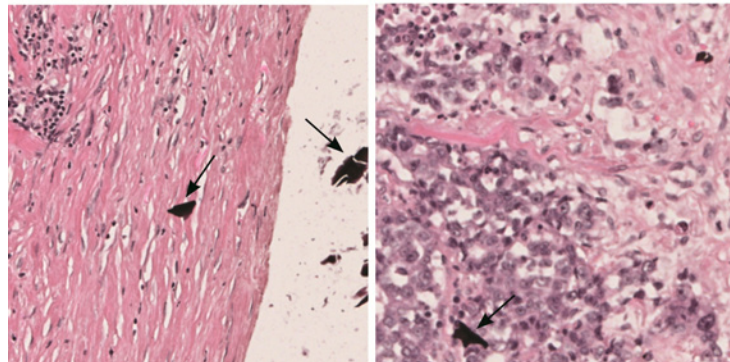
Particulate Matter in H&E Staining

IF Staining Troubleshooting

Weak Antibody Signal

Weak antibody signal in areas of the tissue where strong signal is expected may indicate that a nonideal concentration of antibody was used. Perform antibody optimization to determine the optimal concentration.

Good Signal - DAPI and Antibody Stain

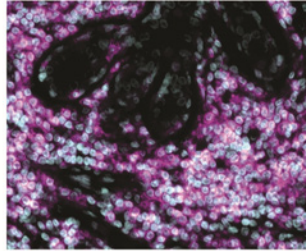

Good Signal - Antibody Stain Only

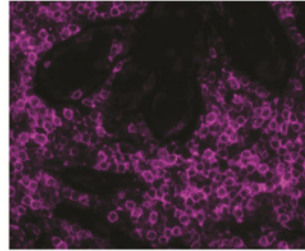

Weak Signal - DAPI and Antibody Stain

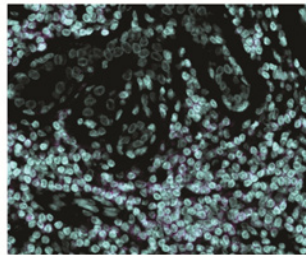

Weak Signal - Antibody Stain Only



Appendix

DV200 Performance and Recommendations

DV200 is a broad measurement of RNA quality and is influenced by factors including:

- Tissue block age, type and composition
- Region selected for RNA extraction
- Presence of diseased or necrotic regions
- Depth of section
- Fixation method
- Miscellaneous upstream tissue handling and processing

10x Genomics recommends that tissues used with the Visium HD Spatial Gene Expression should have a DV200 of > 30%, as measured with a tested RNA extraction kit. See for the Visium HD Spatial Gene Expression Protocol Planner (CG000698) for a list of tested part numbers.

Low DV200 scores do not necessarily result in poor data, but high scores are more likely to correlate with higher sensitivity. The example trace below is from a sample with a DV200 of 78% based upon region selection of 200 to 4,000 nucleotides. The Agilent High Sensitivity RNA ScreenTape, RNA ScreenTape Ladder, and RNA ScreenTape Sample Buffer were used for analyzing the sample. For more information on using Agilent software to determine DV200, refer to the "DV200 determination for FFPE RNA samples" article on the Agilent website.

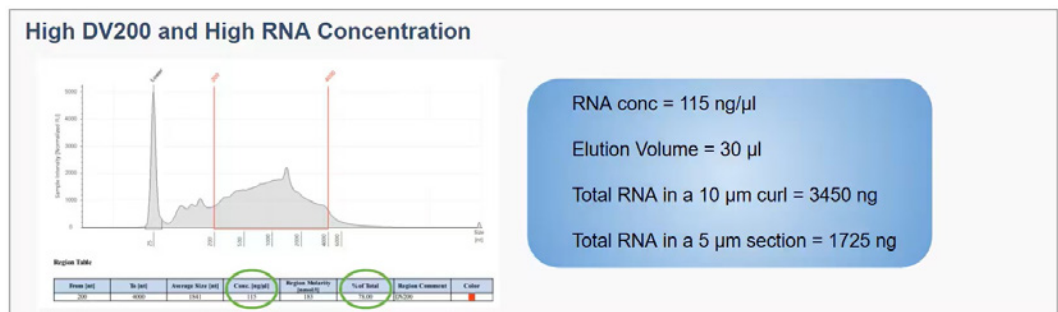

During trace acquisition, review the electropherogram and virtual gel:

- Check for clean ladders and controls, ensuring no unexpected bands or background signals.
- Ensure sample traces are free of contamination or abnormal peaks.
- Set the Region Table to 200–4,000 base pairs. This range excludes small debris or highly fragmented RNA (<200 bp) and potential signal noise or genomic DNA contamination (>4,000 bp).

This allows for accurate estimation of both DV200 and usable RNA concentration for RNA quantity per cell assessment.

Notices

Document Number

CG001676 | Rev A

Legal Notices

© 2026 10x Genomics, Inc. (10x Genomics). All rights reserved. Duplication and/or reproduction of all or any portion of this document without the express written consent of 10x Genomics, is strictly forbidden. Nothing contained herein shall constitute any warranty, express or implied, as to the performance of any products described herein. Any and all warranties applicable to any products are set forth in the applicable terms and conditions of sale accompanying the purchase of such product. 10x Genomics provides no warranty and hereby disclaims any and all warranties as to the use of any third-party products or protocols described herein. The use of products described herein is subject to certain restrictions as set forth in the applicable terms and conditions of sale accompanying the purchase of such product. A non-exhaustive list of 10x Genomics' marks, many of which are registered in the United States and other countries can be viewed at: www.10xgenomics.com/trademarks. 10x Genomics may refer to the products or services offered by other companies by their brand name or company name solely for clarity, and does not claim any rights in those third-party marks or names. 10x Genomics products may be covered by one or more of the patents as indicated at: www.10xgenomics.com/patents. The use of products described herein is subject to 10x Genomics Terms and Conditions of Sale, available at www.10xgenomics.com/legal-notices, or such other terms that have been agreed to in writing between 10x Genomics and user. All products and services described herein are intended FOR RESEARCH USE ONLY and NOT FOR USE IN DIAGNOSTIC PROCEDURES.

Instrument & Licensed Software Updates Warranties

Updates to existing Instruments and Licensed Software may be required to enable customers to use new or existing products.

Support

Email: support@10xgenomics.com

10x Genomics, Inc.

6230 Stoneridge Mall Road

Pleasanton, CA, 94588

Document Revision Summary

Document Number

CG001676

Title

Visium HD FFPE Tissue Preparation 2.0 Handbook

Revision

Rev A

Revision Date

March 11, 2026

Description of Changes

N/A

Take 1 minute to evaluate this protocol. Scan this code or [click here](#).

