



User Guide | CG000584 | Rev F

Xenium Analyzer

For use with:

Xenium Analyzer with 12-Month Warranty, PN-1000481

(Includes Xenium Instrument Bundle, PN-1000569 - Xenium Analyzer, Analysis Computer, Instrument Accessory Kits)



Notices

Document Number

CG000584 | Rev F

Legal Notices

© 2024 10x Genomics, Inc. (10x Genomics). All rights reserved. Duplication and/or reproduction of all or any portion of this document without the express written consent of 10x Genomics, is strictly forbidden. Nothing contained herein shall constitute any warranty, express or implied, as to the performance of any products described herein. Any and all warranties applicable to any products are set forth in the applicable terms and conditions of sale accompanying the purchase of such product. 10x Genomics provides no warranty and hereby disclaims any and all warranties as to the use of any third-party products or protocols described herein. The use of products described herein is subject to certain restrictions as set forth in the applicable terms and conditions of sale accompanying the purchase of such product. A non-exhaustive list of 10x Genomics' marks, many of which are registered in the United States and other countries can be viewed at: www.10xgenomics.com/trademarks. 10x Genomics may refer to the products or services offered by other companies by their brand name or company name solely for clarity, and does not claim any rights in those third-party marks or names. 10x Genomics products may be covered by one or more of the patents as indicated at: www.10xgenomics.com/patents. The use of products described herein is subject to 10x Genomics Terms and Conditions of Sale, available at www.10xgenomics.com/legal-notices, or such other terms that have been agreed to in writing between 10x Genomics and user. All products and services described herein are intended FOR RESEARCH USE ONLY and NOT FOR USE IN DIAGNOSTIC PROCEDURES.

Instrument & Licensed Software Updates Warranties

Updates to existing Instruments and Licensed Software may be required to enable customers to use new or existing products. In the event of an Instrument failure resulting from an update, such failed Instrument will be replaced or repaired in accordance with the 10x Limited Warranty, Assurance Plan or service agreement, only if such Instrument is covered by any of the foregoing at the time of such failure. Instruments not covered under a current 10x Limited Warranty, Assurance Plan or service agreement will not be replaced or repaired.

Support

Email: support@10xgenomics.com
10x Genomics
6230 Stoneridge Mall Road
Pleasanton, CA 94588 USA

Document Revision Summary

Document Number

CG000584 | Rev F

Title

Xenium Analyzer User Guide

Revision

Rev E to Rev F

Revision Date

May 2024

Specific Changes

- Added Ethernet speed in Instrument Specifications table (pg. 9)
- Added information to reflect addition of 5K panel including changes in kits (pg. 26), protocol timing (pg. 47), reagent and buffer preparation (pgs. 49-58), system operations (pgs. 60-62), instrument loading (pgs. 65, 68-69), and cassette assembly (pg. 94)
- Adding changes and new features with XOA 3.0 (pgs. 30, 43-45)
- Added Vibration Isolation Table specifications to Tips and Best Practices (pg. 33)
- Added information about cassette gaps for Xenium Cassette v2 (pg. 92)
- Included guidance on storing slides and cassettes in event of instrument failure (pg. 95)
- Updated images with most recent versions

General Changes

- Updated for general minor consistency of language, terms, images, and format throughout

Table of Contents

Introduction	6
Introduction	7
Product Identification	8
Instrument Specifications	9
Safety & Compliance Information	10
System Components	15
Instrument Installation	16
Accessories & Consumables	20
Accessory Kits	23
Reagent Kits & Consumables	24
Reagent Kits & Consumables <i>For Xenium v1 Workflows</i>	25
Reagent Kits & Consumables <i>For Xenium Prime Workflow</i>	26
Gene Panels	27
Additional Kits, Reagents & Equipment	28
Software Overview	30
Software Overview <i>contd.</i>	31
Tips and Best Practices	32
Icons	33
Handling Xenium Slide with Tissue Section	33
Vibration Isolation Table Specifications	33
Region Selection Guidelines	34
Reagent Plate and Buffer Preparation	35
Cleaning Slides and Cassette Carriers	36
Getting Started	37
Instrument Setup	38
Touchscreen Menu Options	41
Network Connectivity	42
Software Updates <i>For version 1.6 or higher</i>	43
Readiness Test	46
Protocol Steps & Timing	47

Reagent Preparation	48
Step 1: Reagent Plate Preparation	49
Step 2: Buffer Preparation	52
Step 2: Buffer Preparation <i>For Xenium v1 Workflows</i>	54
Step 2: Buffer Preparation <i>For Xenium Prime Workflow</i>	57
System Operation	59
Initialize Instrument	60
Load Consumables	63
Sample Scan	71
Region Selection	74
Initiate Run	75
Post-run Cleanup	76
Unload Consumables	77
Powering OFF Instrument	80
Data Output	81
Maintenance	86
Troubleshooting	91
Troubleshooting	92
Errors	100

Introduction

- 7** Introduction
- 8** Product Identification
- 9** Instrument Specifications

Introduction

Xenium In Situ is the next-level in situ solution for subcellular profiling of hundreds of RNA targets. The Xenium Analyzer instrument combined with our curated and customizable panels, powerful visualization software, and easy-to-follow workflow is a powerful in situ profiling platform, revealing new insights into cellular structure and function.

- **Sample input flexibility:** Compatible with fresh frozen (FF) and formalin fixed & paraffin embedded (FFPE) tissues.
- **Curated targeted gene panels with custom capabilities:** Choose from pre-designed panels or customize a pre-designed panel.
- **Increased speed and throughput:** Large sample area (12 x 24 mm) on the Xenium Slide allows for larger tissues or multiple tissues to be included in a single run, increasing efficiency and saving time.
- **Intuitive instrument design and interface:** Get started quickly with the easy to use instrument design and interface.
- **Robust, flexible platform:** Automated in situ platform that performs successive rounds of fluorescent probe hybridization, imaging, and probe removal to generate an optical signature for each transcript.
- **Onboard analysis:** Image processing, decoding, and secondary analysis are performed in real time on-instrument.
- **Data visualization and analysis:** After data is transferred off the instrument, it can be visualized with the Xenium Explorer desktop software or reanalyzed with the Xenium Ranger Linux software. Xenium Explorer allows for immediate interactivity with on-instrument output, including overlays of transcripts at subcellular resolution, morphology images, segmentation results, and cluster localization. Xenium data is in an open file format, making it compatible with a wide variety of open source software tools.

Compatible Xenium Assays: Xenium v1 and Xenium Prime

The Xenium Analyzer is compatible with the current on-market Xenium assays, Xenium v1 and Xenium Prime.

- Xenium v1 refers to the Xenium In Situ Gene Expression (CG000582) and the Xenium In Situ Gene Expression with Cell Segmentation Staining (CG000749) workflows.
- Xenium Prime refers to the Xenium Prime In Situ Gene Expression with optional Cell Segmentation Staining workflow (CG000760).

Differences in instrument setup exist between the assays that affect output data. Take extra care when performing instrument setup to ensure appropriate assay workflow is selected.

Product Identification

The product label is located at the back panel of the instrument. Images of the labels below are for reference only.

FCC ID: 2ALHY-000537 IC: 222592-000537

This device complies with part 15 of the FCC Rules. Operation is subject to the following two conditions:
 (1) This device may not cause harmful interference, and
 (2) this device must accept any interference received, including interference that may cause undesired operation.

CAUTION RISK OF ELECTRIC SHOCK
DO NOT OPEN

Risk of Electric Shock, do not remove cover.
Refer servicing to qualified service personnel.
 Risque d'électrocution, ne pas retirer le couvercle.
 Pour l'entretien, faire appel à un technicien qualifié.

Ratings: 200-240Vac ~ 50-60Hz 6A MAX

10x GENOMICS www.10xgenomics.com
 For research use only.
 Not for use in diagnostic procedures.





Patents: <https://www.10xgenomics.com/legal-notices#patents>



Xenium Analyzer



PN 1000529

SN XETGXXXYK 

Scan QR code below for product regulatory e-labels.

R-R-10x-XeniumAnalyzer

10x GENOMICS, INC
 Pleasanton, CA, USA
 Assembled in USA



Xenium Analysis Computer

Model Number(型号/型号) 1000534 伺服器/服务器



Input(输入/输入): 100-240Vac ~ 50-60Hz, 8-12A

This device complies with Part 15 of the FCC Rules. Operation is subject to the following two conditions: (1) this device may not cause harmful interference, and (2) this device must accept any interference received, including interference that may cause undesired operation.
 この装置は、クラスA機器です。この装置を住宅環境で使用すると電波妨害を引き起こすことがあります。この場合には使用者が適切な対策を講ずるよう要求されることがあります。
 Caution: Disconnect all power cords before servicing
 Débranchez tous les cordons d'alimentation de l'unité avant d'intervenir
 Ziehen Sie alle Netzkabel vor der Wartung
 警告使用者: 在居住环境中, 运行设备可能会造成无线电干扰。



10x GENOMICS www.10xgenomics.com
 For research use only.
 Not for use in diagnostic procedures.

R-R-10x-Xenium CAN IC ES-3[A] NMB-3[A]

LISTED I.T.E E209323
 Factory ID: 782

10X GENOMICS INC Pleasanton, CA USA
 美國製造/美国制造 Assembled in the USA

Instrument Specifications

Parameter	Xenium Analyzer Specifications		
Weight			
Xenium Analyzer	~550 lb/249.5 kg		<i>Total weight of system: ~1,182 lb (536.1 kg)</i>
Xenium Analysis Computer	~57 lb/25.8 kg		
Vibration Isolation Table	~575 lb/260.8 kg		
Dimensions			
	L	W	H
Xenium Analyzer	52.5"/133.3 cm	27"/68.5 cm	31"/78.7 cm <i>59"/149.8 cm - door open</i>
Xenium Analysis Computer	7"/17.8 cm	26.5"/67.3 cm	18"/45.7 cm
Vibration Isolation Table	53.2"/135.0 cm	29.9"/76.0 cm	31.1"/79.0 cm
UPS (<i>APC SRT3000XLT or similar; not provided by 10x Genomics</i>)	3.4"/8.5 cm	25"/63.5 cm	17"/43.2 cm
Xenium Analyzer Electrical Specifications	200-240 VAC, 50-60 Hz, 6 A*		
Pollution Degree	2 (Indoor Use Only)		
Operating Temperature	19-25°C (66-77°F) <i>Use in a typical indoor laboratory environment. Extreme temperature conditions will affect the sensitive reagents used with the instrument.</i>		
Humidity	30-80% Relative Humidity, non-condensing		
Altitude	Altitude up to 2,000 m (1.2 mile) above sea level		
Environmental Vibration Guidelines	ISO Office (or better) during idle ISO Operating Theater (or better) during run <i>No bumps or shocks adjacent to or on the Vibration Isolation Table during a run</i>		
Heat Output	~2,000 W (6,820 BTU/h) <i>Combined output from the Xenium Analyzer & the Xenium Analysis Computer</i>		
Power Cable Length	~1.83-3 m (~6-9.8 ft) <i>Cables will be in accordance with regional specifications</i>		
Xenium Analysis Computer Specifications	RAM: 1TB DDR4-3200 ECC RDIMM Storage Capacity: 8 TB NVMe Ethernet Link Speed: 10Gbps Operating System: Ubuntu 22.04 LTS (non-configurable)		
Xenium Analysis Computer Electrical Specifications	200-240 VAC, 50-60 Hz, 6 A*		
Vibration Isolation Table Gauge Specifications**	Source air supply (compressor, wall air, tank, etc): ~80-150 psi Table air supply: ~70-80 psi Table leg pressure: ~50-60 psi		

*Electrical requirements dependent on region/country

**Contact support@10xgenomics.com if table specifications are out of range.

Safety & Compliance Information







- 11** Xenium Analyzer Safety & Regulatory Information
- 13** Xenium Analysis Computer Safety & Regulatory Information

Xenium Analyzer Safety

Before operation, ensure that all potential users have received:

- Instruction in general safety practices for laboratories.
- Instruction in specific safety practices for the instrument.
- All related Safety Data Sheet (SDS) documents.

Precautions are illustrated in the following way:

Symbols	Description
	The general Warning symbol indicates the possibility of damaging the instrument or compromising the results of a method.
	The Electrical Hazard symbol indicates the presence of electrical components that can be harmful to the operator if handled incorrectly.
	The Mechanical Hazard symbol indicates the presence of moving mechanical parts that can be harmful to the operator if handled incorrectly.
	The Hazardous Materials symbol indicates the presence of materials that are toxic or otherwise harmful to the operator if handled incorrectly.
	The Biohazard symbol indicates the presence of biological samples that can be harmful to the operator if handled incorrectly.
	The Caution, Hot Surface symbol indicates the possibility of touchable surface that may exceed 105°C.



Ensure ground is reliably connected before plugging the instrument’s power cord into the power source (receptacle). *Grounding is required to prevent electric shock. If the power source is not grounded, qualified personnel must first install a reliable safety ground.*



Warning: The door is capable of moving an object that is in its opening path. If an object is in the path, the object could fall and create a hazard.



Pinch risk: Ensure no obstructions or fingers present near closing trays. Once the system is floating, keep fingers away from the area between the support plate and the top of the isolators. Any object between these points may be caught if the load or air supply changes.









Warning: Avoid using the Xenium Analyzer in a manner not specified by 10x Genomics. *The Xenium Analyzer has been designed to protect the user. If used improperly, the intended user protections can be impaired.*



Heavy Load: 1,183 lb (536.1 kg). Contact 10x Genomics Service Personnel for Lifting and Installation.

Xenium Analyzer Regulatory

The Xenium Analyzer has been designed, tested, and certified to be in compliance with the following standards:

Certification	Standards
	TUV Certification only for Xenium Analyzer UL 61010-1:2012 and CAN/CSA C22.2 No. 61010-1-12 with a cTUVus mark to indicate that the product has been tested and certified to Canadian and US standards by TUV Rheinland and can be legally installed in those countries.
	IEC/EN 61010-1:2010 (3rd Edition): Safety Requirements for Electrical Equipment for Measurement, Control, and Laboratory use.
	EN 61326-1:2013: Electrical Equipment for Measurement, Control and Laboratory Use. EMC Requirements.
	The RCM mark indicates an electrical product complies with all the requirements of the electrical and EMC regulations of Australia and New Zealand in accordance with AS/NZS Standards.
	CE Mark indicates that assembly is covered by a Declaration of Conformity, and has been declared in conformity with the provisions of all applicable directives in the European Union.
	UKCA Mark indicates that assembly is covered by a Declaration of Conformity, and has been declared in conformity with the provisions of all applicable directives in the United Kingdom.
	EN 61326-2-6: Specifies minimum requirements for immunity and emissions regarding electromagnetic compatibility for in vitro diagnostic medical equipment, taking into account the particularities and specific aspects of this electrical equipment and their electromagnetic environment.
	EN 61000-3-2: Electromagnetic compatibility (EMC) - Part 3-2: Limits - Limits for harmonic current emissions (equipment input current ≤16 A per phase).
	EN 61000-3-3: Electromagnetic compatibility (EMC) - Part 3-3: Limits - Limitation of voltage changes, voltage fluctuations and flicker in public low-voltage supply systems, for equipment with rated current ≤16 A per phase and not subject to conditional connection.
	RoHS Directive (2011/65/EU) and amendment (EU) 2015/863: Restriction of the use of certain hazardous substances in electrical and electronic equipment.
	WEEE Directive (2012/19/EU): Waste Electrical and Electronic Equipment.
	FCC Part 15 Class A. NOTE: This equipment has been tested and found to comply with the limits for a Class A digital device, pursuant to part 15 of the FCC Rules. These limits are designed to provide reasonable protection against harmful interference when the equipment is operated in a commercial environment. This equipment generates, uses, and can radiate radio frequency energy and, if not installed and used in accordance with the instruction manual, may cause harmful interference to radio communications. Operation of this equipment in a residential area is likely to cause harmful interference in which case the user will be required to correct the interference at his own expense. This device complies with part 15 of the FCC Rules. Operation is subject to the following two conditions: (1) This device may not cause harmful interference, and (2) this device must accept any interference received, including interference that may cause undesired operation.
	ICES-003 (Canada): This Class A digital apparatus complies with Canadian ICES-003. Cet appareil numérique de la classe A est conforme à la norme NMB-003 du Canada.
	Complies to Japan's Ministry of Economy, Trade and Industry (METI) Electrical Appliance and Material Safety Law (DENAN). This is a Class A product based on the standard of the Voluntary Control Council for Interference (VCCI). If this equipment is used in a domestic environment, radio interference may occur, in which case the user may be required to take corrective actions. これは電波障害自主規制協議会 (VCCI) の基準に基づくクラス A 製品です。 この装置を家庭環境で使用すると、無線干渉が発生する可能性があります。その場合、ユーザーは是正措置を講じる必要があります。 VCCI-A

Xenium Analysis Computer Safety

Before operation, ensure that all potential users have received:

- Instruction in general safety practices for laboratories.
- Instruction in specific safety practices for the instrument.



Warning: Read the installation instructions before connecting the system to the power source.



Warning: Only trained and qualified personnel should be allowed to install, replace, or service this equipment.



Warning: Installation of the equipment must comply with local and national electrical codes.



Warning: Keep fingers, screwdrivers, and other objects away from the openings in the fan assembly's housing.



Warning: When installing the product, use the provided or designated connection cables, power cables, and AC adaptors. Using any other cables and adaptors could cause a malfunction or a fire.

Xenium Analysis Computer Regulatory

The Xenium Analysis Computer has been designed, tested, and certified to be in compliance with the following standards:

Certification	Standards
	UL Certification only for Xenium Analysis Computer UL 62368-1: 2019 and CAN/CSA-C22.2 NO. 62368-1:12 with a cULus mark to indicate that the product has been tested and certified to Canadian and US standards by UL and can be legally installed in those countries.
	IEC 62368-1: Audio/video, information and communication technology equipment - Part 1: Safety requirements.
	EN 55032:2015+A11:2020 (Class A) - Electromagnetic compatibility of multimedia equipment - Emission Requirements EN 55035:2017+A11:2020 - Electromagnetic compatibility of multimedia equipment - Immunity requirements.
	The RCM mark indicates an electrical product complies with all the requirements of the electrical and EMC regulations of Australia and New Zealand in accordance with AS/NZS Standards.
	CE Mark indicates that assembly is covered by a Declaration of Conformity, and has been declared in conformity with the provisions of all applicable directives in the European Union.
	UKCA Mark indicates that assembly is covered by a Declaration of Conformity, and has been declared in conformity with the provisions of all applicable directives in the United Kingdom.
	EN 61000-3-2: Electromagnetic compatibility (EMC) - Part 3-2: Limits - Limits for harmonic current emissions (equipment input current ≤16 A per phase).
	EN 61000-3-3: Electromagnetic compatibility (EMC) - Part 3-3: Limits - Limitation of voltage changes, voltage fluctuations and flicker in public low-voltage supply systems, for equipment with rated current ≤16 A per phase and not subject to conditional connection.
	RoHS Directive (2011/65/EU) and amendment (EU) 2015/863: Restriction of the use of certain hazardous substances in electrical and electronic equipment.
	WEEE Directive (2012/19/EU): Waste Electrical and Electronic Equipment.
	FCC Part 15 Class A. NOTE: This equipment has been tested and found to comply with the limits for a Class A digital device, pursuant to part 15 of the FCC Rules. These limits are designed to provide reasonable protection against harmful interference when the equipment is operated in a commercial environment. This equipment generates, uses, and can radiate radio frequency energy and, if not installed and used in accordance with the instruction manual, may cause harmful interference to radio communications. Operation of this equipment in a residential area is likely to cause harmful interference in which case the user will be required to correct the interference at his own expense. This device complies with part 15 of the FCC Rules. Operation is subject to the following two conditions: (1) This device may not cause harmful interference, and (2) this device must accept any interference received, including interference that may cause undesired operation.
	ICES-003 (Canada): This Class A digital apparatus complies with Canadian ICES-003. Cet appareil numérique de la classe A est conforme à la norme NMB-003 du Canada.
	China CCC: GB 17625.1-2012;GB 4943.1-2011;GB/T 9254.1-2021(Class A).
	Complies to Japan's Ministry of Economy, Trade and Industry (METI) Electrical Appliance and Material Safety Law (DENAN). This is a Class A product based on the standard of the Voluntary Control Council for Interference (VCCI). If this equipment is used in a domestic environment, radio interference may occur, in which case the user may be required to take corrective actions. <small>これは電波障害自主規制協議会 (VCCI) の基準に基づくクラス A 製品です。 この装置を家庭環境で使用すると、無線干渉が発生する可能性があります。その場合、ユーザーは是正措置を講じる必要があります。</small>

VCCI-A

System Components

- 16** Instrument Installation
- 20** Accessories & Consumables
- 23** Accessory Kits
- 24** Reagent Kits & Consumables
- 27** Gene Panels
- 28** Additional Kits, Reagents & Equipment
- 30** Software Overview

Instrument Installation

10x Genomics will provide complete installation services necessary for Xenium Analyzer, Vibration Isolation Table, and Xenium Analysis Computer.

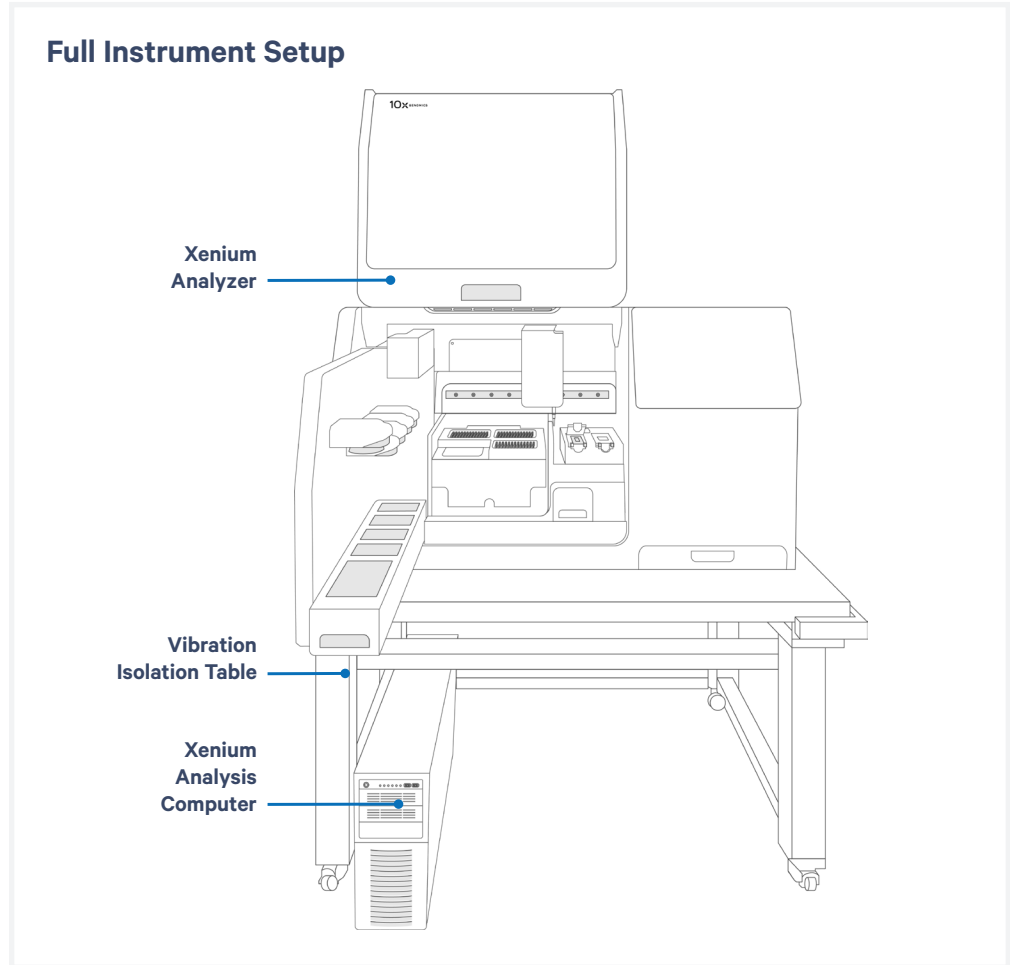

System Components - Xenium Analysis Computer

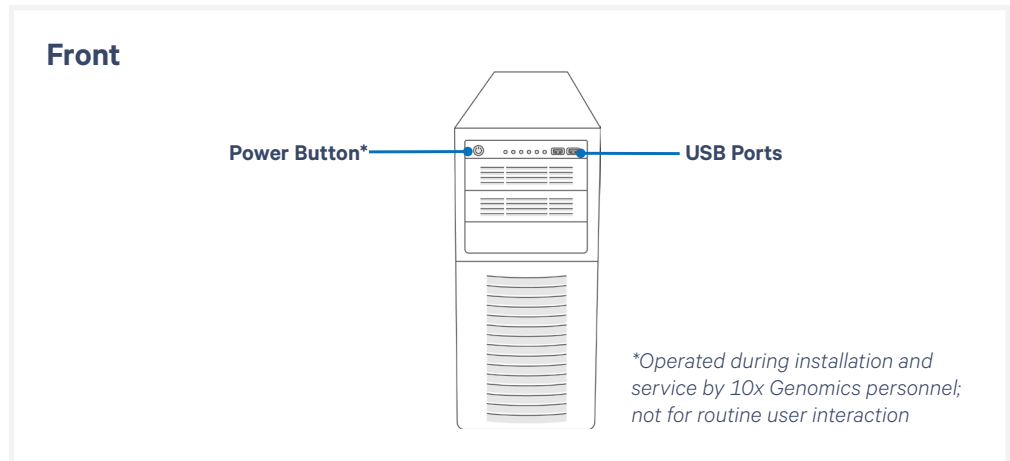

System Components - Xenium Analyzer

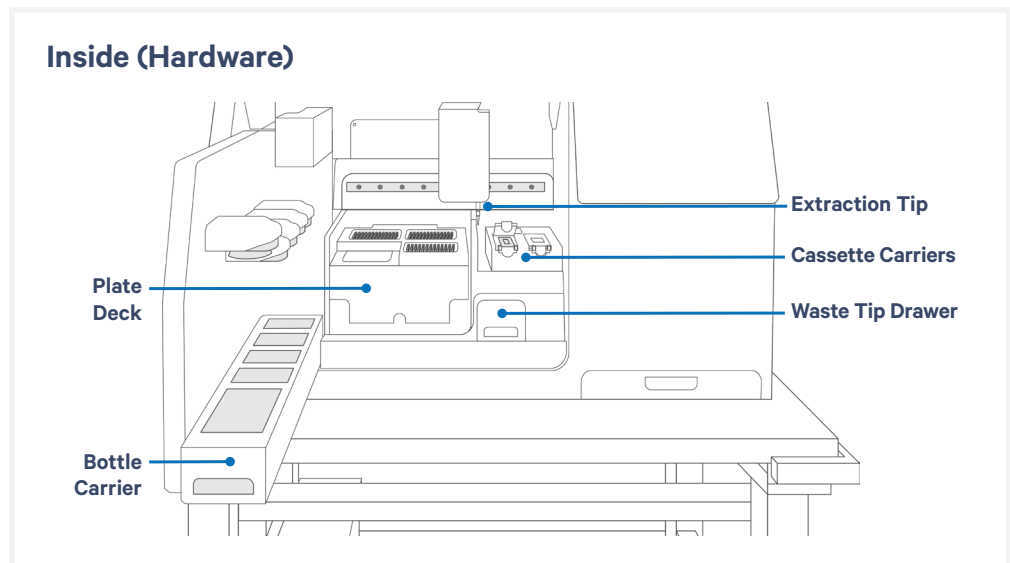
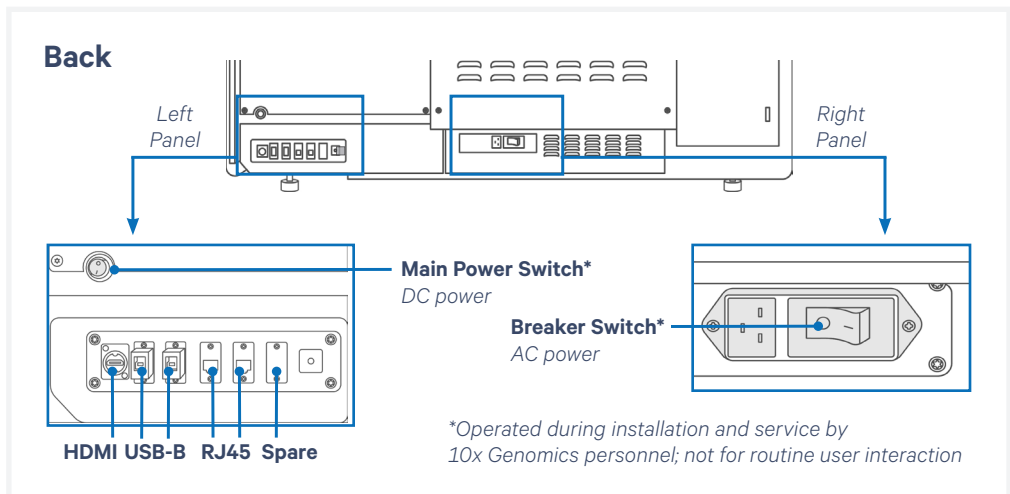
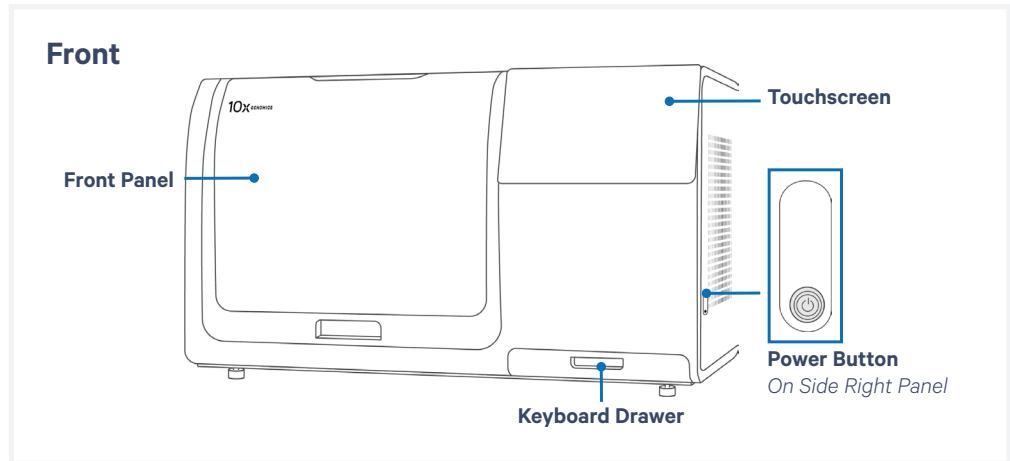

Deck Layout - Xenium Analyzer

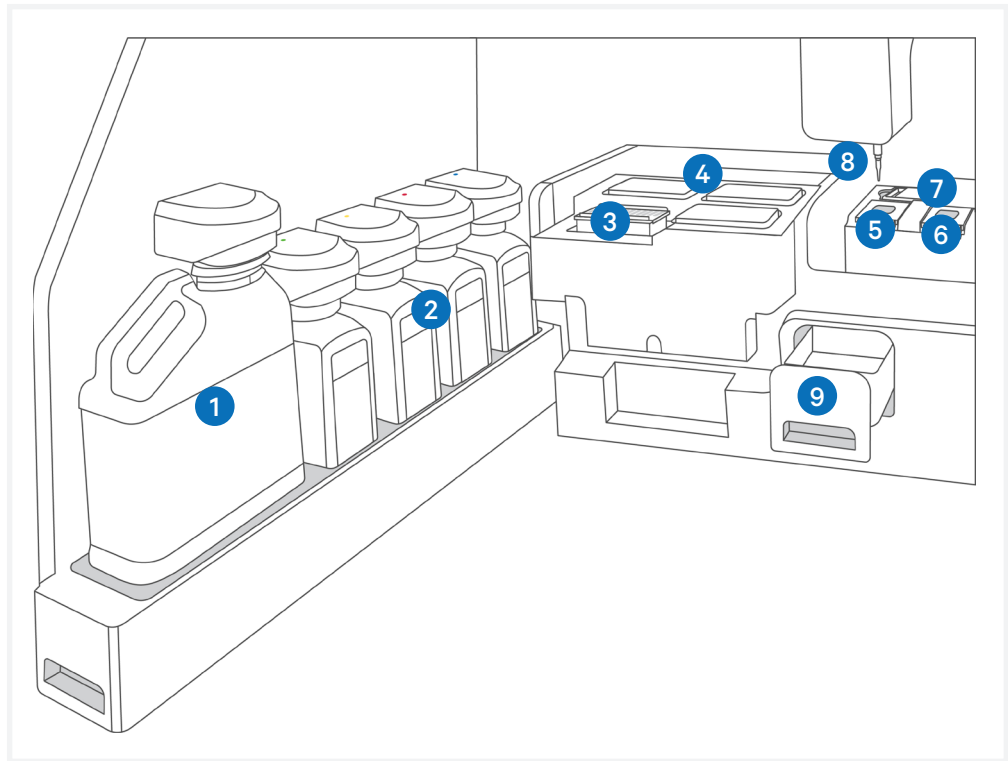

Location	Part
Bottle Carrier	1 Waste Bottle
	2 Reagent Bottles (4 total)
Plate Deck	3 Pipette Tip Rack
	4 Reagent Plates (2 or 3, depending on assay method)
Cassette Carrier	5 Left Cassette (lid open)
	6 Right Cassette (lid closed)
	7 Objective Wetting Consumable (OWC)
	8 Extraction Tip
	9 Waste Tip Drawer (Waste tip tray inside)

Hardware Components - Xenium Analyzer



Avoid using the touchscreen and keyboard during instrument runs; if needed, use the touchscreen instead of the keyboard.

The Xenium Analyzer includes the following hardware components designed for seamless workflow execution. Refer to the [System Components](#) and [Deck Layout](#) sections for the specific location of each hardware component.

Touchscreen

The touchscreen is located on the right side of the instrument. Interaction with the software user interface is performed here.

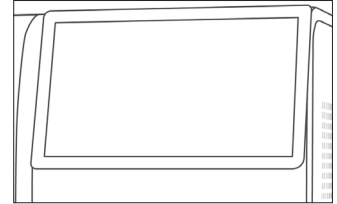

Keyboard Drawer

The wireless keyboard drawer is located on the bottom right corner of the instrument, underneath the touchscreen. A keyboard with trackpad is provided to aid in navigating the user interface.

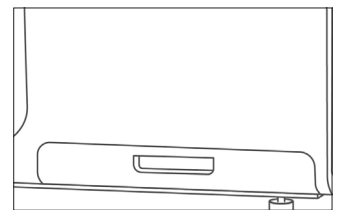

Bottle Carrier

Within the instrument deck, the bottle carrier is located at the far left. It can be pulled out using the handle and the Waste Bottle and reagent bottles are housed in the carrier.

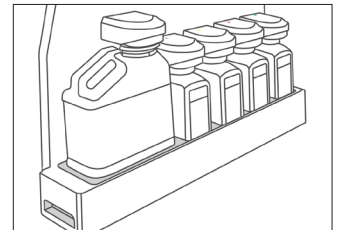

Waste Tip Drawer

The waste tip drawer is located toward the bottom right of the instrument deck. Pulling the handle to open will reveal the Waste Tip Tray where all solid waste (i.e. tips) is deposited during a run.

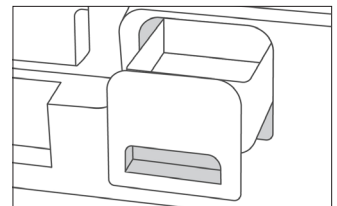
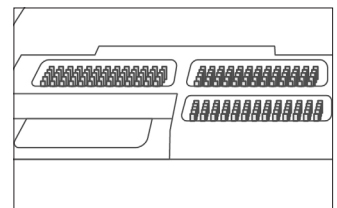

Plate Deck

The plate deck is in the center of the instrument deck. Pipette tips and reagent plates sit here.



Cassette Carrier

Two cassette carriers sit to the right of the plate deck. Front tabs are used to open carriers to load slide cassettes.



Carrier lid must be fully opened prior to loading the slide cassette. If not fully open and/or the slide is not sitting correctly, closing the carrier lid will crush/break slide.

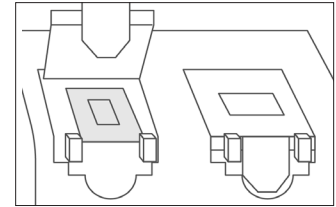

Caution: Hot surface (gray region) during instrument run

Accessories & Consumables

The Xenium Analyzer uses the following accessories and consumables required for operation. Unless otherwise noted, each consumable is good for **one run and must be replaced** before the start of each run. Refer to the [Deck Layout](#) section for specific locations of each item.

Not all accessories and consumables are shipped with the instrument. Refer to the [Accessory Kits](#) and [Reagent Kits and Consumables](#) sections for complete details.

Objective Wetting Consumable (OWC)

The OWC sits behind the slide cassettes/cassette carrier. It has four parts: the reagent priming reservoir, the objective drying pad, the objective wash reservoir, and the extract orifice.

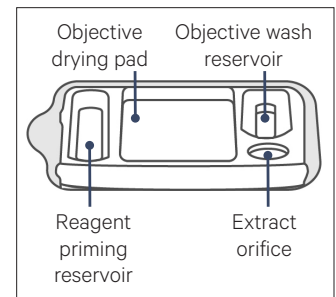

Waste Bottle (Reusable)

The liquid Waste Bottle sits in the front position of the bottle carrier. It serves as a receptacle for all liquid waste that is generated during a Xenium run. The Waste Bottle is reusable and should be emptied after each run when prompted and returned back to position before starting the next run.



Follow institutional or local guidelines for proper liquid waste disposal

Accessories & Consumables

contd.

Reagent Bottles (x4)

Four reagent bottles sit in the bottle carrier behind the Waste Bottle. Bottles are color coded to the instrument. Place bottles in the correct order when prompted to.



Follow institutional or local guidelines for proper liquid waste disposal

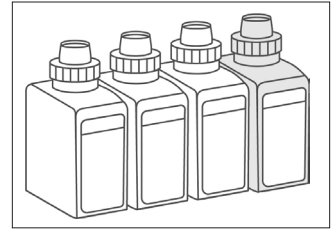

Waste Tip Tray (Reusable)

The Waste Tip Tray sits inside the waste tip drawer. Solid waste (i.e. tips) generated during each run is stored in the waste tip container. It can be reused between runs, but must be emptied after each run.



Follow institutional or local guidelines for proper solid waste disposal

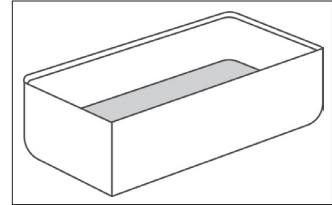

Pipette Tip Rack

Pipette tip rack (1 ml tips) sit in the front left area of the plate deck and is labeled with a T on the front. Tips facilitate the movement of liquids during an experiment. **Single use only**, discard after each run.

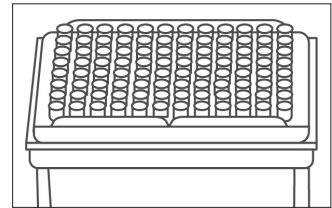

Reagent Plates

Two required reagent plates (Plate A and B) sit behind the Pipette Tip Rack. A third reagent plate sits right of the Pipette Tip Rack and is required depending on assay method.

Plates are specific to its location and contains unique reagents. Specific handling and preparation is required prior to loading and are described in [Reagent Plate Preparation](#) section. All plates are **single use only** and must be discarded after each run.



The foil seal on the plates should be intact when loading instrument. DO NOT use plates if foil seal is punctured.

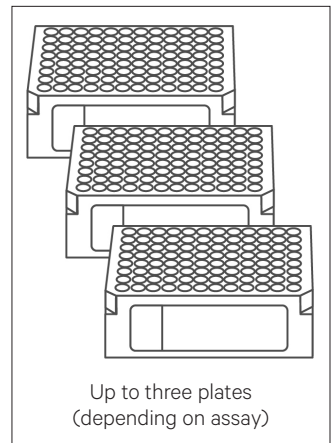

Accessories and Consumables

contd.

Extraction Tip

The Extraction Tip is used to facilitate liquid waste transfer from the OWC to the Waste Bottle container and to aspirate liquid from the loaded cassette. The Extraction Tip is a **single use item** and must be discarded after each run.

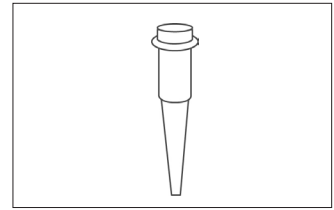

Xenium Buffer Cap

Reagent bottles must be capped using the Xenium Buffer Cap (includes an integrated straw) prior to loading onto the instrument. These special caps allow for bottles to be locked into place in the bottle carrier. Four are provided (one per reagent bottle); all are **single use only** and must be discarded after each run.

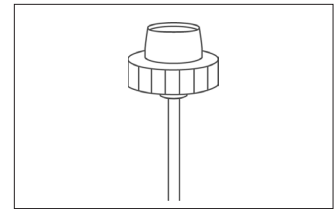

Accessory Kits

Xenium Instrument Bundle, PN-1000569

Includes Xenium Analyzer and Xenium Analysis Computer* (PN-1000529)

Instrument Accessory Kit Module A & Module B

Thermocycler Adaptor & Thermocycler Adaptor v2**

*Xenium Analysis Computer only PN-1000534

**Required for sample preparation performed prior to instrument loading (CG000578, CG000580, CG000581, CG000582)

Xenium Instrument Accessory Kit Module A, PN-1000530 *shipped with instrument*

Item	#	Part Number
Waste Bottle	1	3000955
Xenium Waste Tip Tray	1	3000957

Region-specific Xenium Power Cable Kit will be shipped along with the Xenium Instrument Accessory Kit Module A.

Xenium Instrument Accessory Kit Module B, PN-1000582 *shipped with instrument*

Item	#	Part Number
Coolant Bottles	2	3001331
Ethernet Cable, 8 ft.	2	3001335
Ethernet Cable, 20 ft.	1	3001611
HDMI Cable	1	3001337
USB Cable, 3.0 A Male to B Male	1	3001336
Foot Mounting Brackets	4	3001765
Foot Mounting Screws**	10	3001766
USB 3.2, 1TB, USB-A & USB-C	1	3002174

**Eight screws are required for Xenium Instrument. Two additional screws are provided

Xenium Thermocycler Adaptor, PN-1000623 *shipped with instrument*

Item	#	Part Number
Xenium Thermocycler Adaptor*	1	3000954

Xenium Thermocycler Adaptor v2, PN- 1000739 *shipped with instrument*

Item	#	Part Number
Xenium Thermocycler Adaptor v2*	1	3002207

Reagent Kits & Consumables

The following reagent kits and consumables are needed for loading a Xenium Analyzer run. Additionally, some kit components are required for steps prior to instrument operation.

Reagent kits vary based on assay workflow. The table below summarizes the specific reagent kits and consumables and associated part numbers that are required depending on upstream workflow performed.

Assay Workflow		
Xenium In Situ Gene Expression (CG000582)	Xenium In Situ Gene Expression with Cell Segmentation Staining (CG000749)	Xenium Prime In Situ Gene Expression with optional Cell Segmentation Staining (CG000760)
Xenium Decoding Consumables PN-1000487	Xenium Decoding Consumables PN-1000487	Xenium Decoding Consumables v2 PN-1000726
Xenium Decoding Reagents PN-1000461	Xenium Decoding Reagents PN-1000461	Xenium Prime 5K Decoding Reagents PN-1000740
	Xenium Cell Segmentation Reagents PN-1000639	Xenium Reagent Bottles PN-1000730

Contents of each kit are detailed below. Confirm receipt of all relevant reagents and kits prior to starting an experiment.

Reagent Kits & Consumables

For Xenium v1 Workflows



Refer to SDS for instructions on proper handling and disposal of volatile and hazardous chemicals.

Use the following reagent kits when performing Xenium In Situ Gene Expression (CG000582) and Xenium In Situ Gene Expression with Cell Segmentation Staining (CG000749) workflows.

Instrument runs with slides prepared for Xenium In Situ Gene Expression with Cell Segmentation require all three reagent kits.

Xenium Decoding Consumables (1 run, 2 slides) PN-1000487

Items (store at room temperature)	#	Part Number
Xenium Cassette Kit* (2 cassettes + 16 lids)	1	1000566
Extraction Tip	1	2000757
Pipette Tips	1	3000866
Xenium Buffer Cap	4	3000949
Xenium Objective Wetting Consumable	1	2000749
1 Deionized Water (bottle)	1	3001198
2 Xenium Sample Wash Buffer A (bottle)	1	3001199
3 Xenium Sample Wash Buffer B (bottle)	1	3001200
4 Xenium Probe Removal Buffer (bottle)	1	3001201

*Use during for sample preparation prior to loading the instrument (CG000580, CG000581).

Xenium Decoding Reagents (1 run, 2 slides) PN-1000461

Items	#	Part Number
A Xenium Decoding Reagent Module A (store at 4°C)	1	1000624
B Xenium Decoding Reagent Module B (store at -20°C)	1	1000625



Decoding Reagent Modules A and B require different storage conditions. Refer to packaging for proper storage instructions upon receipt. Failure to comply with storage instructions will render reagents unusable.

Visually inspect the mylar packaging of Decoding Module A upon receipt to ensure it is vacuum sealed. If it is compromised, use another package and contact support@10xgenomics.com.

Xenium Cell Segmentation Detection Reagents (1 run, 2 slides) PN-1000639

Items	#	Part Number
C Xenium Cell Segmentation Detection Module (store at -20°C)**	1	1000639

**For Xenium In Situ Gene Expression with Cell Segmentation Staining (CG000749) workflow

Reagent Kits & Consumables

For Xenium Prime Workflow



Refer to SDS for instructions on proper handling and disposal of volatile and hazardous chemicals.

Use the following reagent kits when performing the Xenium Prime In Situ Gene Expression with optional Cell Segmentation Staining workflow (CG000760).

No additional decoding reagent plates are required if performing cell segmentation staining.

Xenium Decoding Consumables v2 (1 run, 2 slides) PN-1000726

Items (store at room temperature)	#	Part Number
Xenium Cassette Kit v2* (2rxns) • includes 2 Cassettes v2, 8 Cassette Lids v2, and 4 Cassette Inserts	1	1000723
Extraction Tip	1	2000757
Pipette Tips	1	3000866
Xenium Buffer Cap	4	3000949
Xenium Objective Wetting Consumable	1	2000749

*Required for sample preparation, which is performed prior to loading the instrument (Documents CG000580, CG000581).

Xenium Reagent Bottles PN-1000730

Items (store at room temperature)	#	Part Number
1 Deionized Water (bottle)	1	3001198
2 Xenium Sample Wash Buffer A (bottle)	1	3001199
3 Xenium Sample Wash Buffer B (bottle)	1	3001200
4 Xenium Probe Removal Buffer (bottle)	1	3001201

Xenium Prime 5K Decoding Reagents (2 rxns) PN-1000740

Items	#	Part Number
A Xenium Prime Decoding Reagent Module A (store at 4°C)	1	1000721
B Xenium Prime Decoding Reagent Module B - 5K (store at -20°C)	1	1000722

Gene Panels

Prior to executing the Xenium In Situ Gene Expression workflow, ensure that a compatible gene panel has been selected. 10x Genomics provides the following types of probe panels: pre-designed, add-on custom, and standalone custom. Add-on custom panels are used to supplement pre-designed panels. Standalone custom probe panels are used alone and do not require pre-designed panels.

10x Genomics Pre-designed Gene Panels

Visit the 10x Genomics Support website for the most current information regarding all the available pre-designed panels.

Compatible Custom Gene Panels

Contact your 10x Genomics Sales Executive for information about designing custom gene panels that are compatible with pre-designed panels or standalone custom gene panels. If you do not know your Sales Executive, contact customerservice@10xgenomics.com.

Lead time for acquiring custom panels is up to 8 weeks (1-4 weeks for design, 4 weeks for manufacturing). Visit the 10x Genomics website for the most current information.

If using a custom panel, note the Design ID on the label of the tube containing the panel. This Design ID on the tube label should match with the custom gene panel electronic filename that is selected on the touchscreen during instrument run (see [Initialize Instrument](#) section).

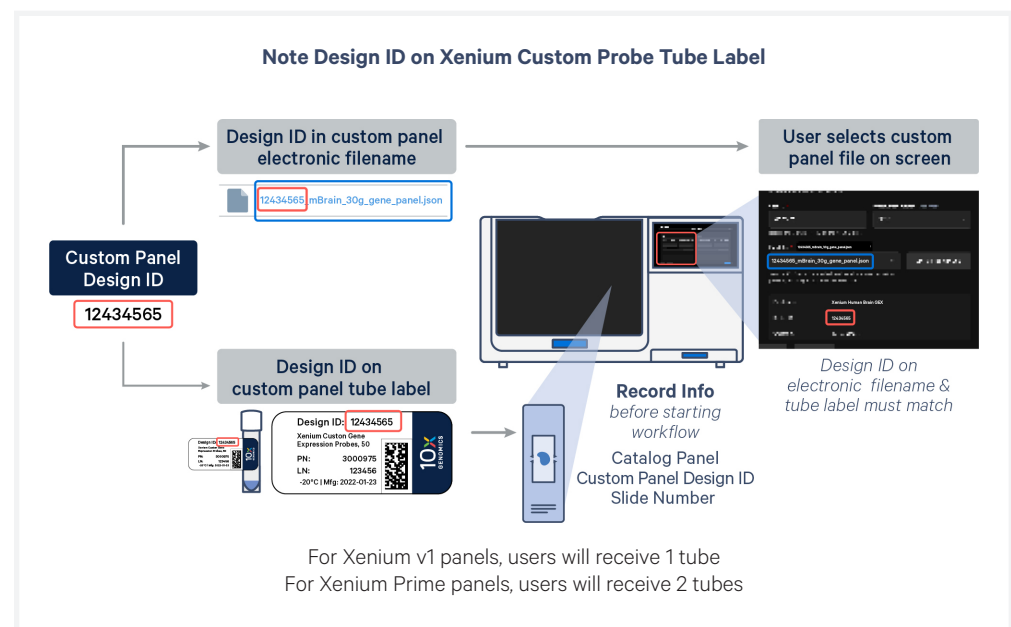

Additional Kits, Reagents & Equipment

The listed items have been tested by 10x and perform optimally with the assay. Substituting materials may adversely affect system performance. For items with multiple options listed, choose option based on availability and preference. Refer to the manufacturer's website for regional part numbers.

For Reagent Bottle Buffer Preparation			
Item	Description	Vendor	Part Number
<input type="checkbox"/>	Nuclease-free Water	Nuclease-free Water (not DEPC-treated)	Thermo Fisher Scientific AM9932/AM9937
		Nuclease-free MilliQ water (Biopak® Polisher) <i>(select one based on availability)</i>	Millipore Sigma CDUFBIOA1
<input type="checkbox"/>	PBS-T	Phosphate Buffered Saline with 0.05% Tween 20, pH 7.4	Millipore Sigma P3563-10PAK
		Phosphate Buffered Saline with 0.05% Tween 20, pH 7.4 <i>(select one based on availability)</i>	Millipore Sigma PPB005-20PAK
<input type="checkbox"/>	PBS <i>Alternate for making PBS-T</i>	PBS - Phosphate Buffered Saline (10X) pH 7.4, RNase-free	Thermo Fisher Scientific AM9624
<input type="checkbox"/>	Tween 20	Tween 20 Surfact-Amps Detergent Solution (10% solution) <i>(use one ampule per use)</i>	Thermo Fisher Scientific 28320
		10% Tween 20	Bio-Rad 1662404
<input type="checkbox"/>	100% DMSO	Dimethyl sulfoxide (molecular biology grade)	Millipore Sigma 41639-100 ML
		Dimethyl sulfoxide (molecular biology grade)	Millipore Sigma 41639-500 ML
		Dimethyl sulfoxide (molecular biology grade)	Millipore Sigma D8418-250ML
		Dimethyl sulfoxide (molecular biology grade)	Millipore Sigma D8418-1L
		Dimethyl sulfoxide, Fisher BioReagents (>99.7%)	Fisher Scientific BP231-1
		Dimethyl sulfoxide (for molecular biology, 99.5+%) <i>(select one based on availability)</i>	Fuji Film 043-29355 500 ml
<input type="checkbox"/>	KCl	Potassium Chloride (KCl, sterile), 500 ml	Teknova P0330
		Potassium Chloride (KCl, sterile), 1L	Teknova P0335
		KCl (2 M), RNase-free <i>(concentration in working solution will be 50 mM; select one based on availability)</i>	Invitrogen AM9640G
Additional Materials			
<input type="checkbox"/>	Centrifuge with plate rotor	Allegra X-14 Series Benchtop Centrifuge 120 V <i>Or equivalent; fits deep-well 96 well plates (~2 ml vol.)</i>	Beckman Coulter Coulter -
<input type="checkbox"/>	Serological Pipettes	10 ml, 25 ml, 50 ml, 100 ml	
<input type="checkbox"/>	Serological Pipette Controller	Compatible with 10, 25, 50 & 100 ml serological pipettes	
<input type="checkbox"/>	Graduated Cylinders	100 ml and other volumes as needed	

Contd.

Additional Kits, Reagents & Equipment

contd.

The listed items have been tested by 10x and perform optimally with the assay. Substituting materials may adversely affect system performance. For items with multiple options listed, choose option based on availability and preference. Refer to the manufacturer's website for regional part numbers.

Additional Materials				
<input type="checkbox"/>	Pipette Tips	Tips LTS 1ML Filter RT-L1000FLR <i>Or equivalent</i>	Rainin	30389213
<input type="checkbox"/>	Pipettes	Pipet-Lite LTS Pipette L-1000XLS+ <i>Or equivalent</i>	Rainin	17014382
<input type="checkbox"/>	Glass Bottles with Cap	Pyrex Reusable Media Storage Bottles (500 ml and 1 l) <i>Or equivalent</i>		
<input type="checkbox"/>	Compressed Canned Air for cleaning			
<input type="checkbox"/>	Lens-cleaning Paper or Lint-free Laboratory Wipes <i>High-Tech Conversions ULTIMATE 9 Quilted 2-Ply Polyester Wipes from Fisher Scientific or equivalent</i>			
<input type="checkbox"/>	70% Isopropanol			
<input type="checkbox"/>	70% Ethanol			
<input type="checkbox"/>	Laboratory Balance			
<input type="checkbox"/>	Ultrapure water	Ultrapure/Milli-Q water, <i>from Milli-Q Integral Ultrapure Water System or equivalent</i>		

This list may not include some standard laboratory equipment.

Software Overview

On-Instrument Pipeline Overview

The Xenium Analyzer includes an on-instrument analysis pipeline. The Xenium Analyzer captures vertical stacks of images at every cycle (of fluorescent probe hybridization, imaging, and probe removal) and in every channel for multiple fields of view, which need to be processed, corrected and stitched to build a single seamless image representing the tissue section. The pipeline detects puncta in every cycle and every image in order to observe all potential mRNA. These puncta are decoded into gene IDs, and each decoded transcript is assigned a quality score.

To define boundaries and assign transcripts to cells, multimodal segmentation is performed. Default segmentation uses DAPI images, 5 μ m expansion, and a neural network.

If samples were prepared for multimodal segmentation, cell boundaries are determined using the Multi-Tissue Stain Mix. Finally, the pipeline outputs a bundle of data files (see [Data Output](#)) that can be exported for further downstream analysis.

Xenium Analyzer Software Versions

The table below summarizes software version requirements based on assay workflow performed.



Confirm instrument is running correct software version before initiating run.
Upgrading software just prior to instrument loading is not advised.

Assay	Software version requirements		
	XA v3.0	XA v2.0	XA v1.0-1.9
Xenium Prime Gene Expression with optional Cell Segmentation (CG000760)	✓		
Xenium In Situ Gene Expression + Cell Segmentation (CG000749)	✓	✓	
Xenium In Situ Gene Expression (CG000582)	✓	✓	✓

Software Overview

contd.

Xenium Explorer Overview

The Xenium Explorer software can be installed on Mac or Windows computers for off-instrument downstream analysis and visualization. It is an easy-to-use tool that enables users to zoom in and out of regions of interest, map gene expression data and cell segmentation boundaries, and assess cluster assignments to known tissue types as layers on top of DAPI-stained microscopy images. Users can check data quality and export or share data to inform downstream analyses.

Visit the [10x Genomics Support website](#) for additional information.

Xenium Ranger Overview

Xenium Ranger provides flexible off-instrument reanalysis of Xenium In Situ data. Relabel transcripts, resegment cells with the latest 10x segmentation algorithms, or import your own segmentation data to assign transcripts to cells. Updated results can be visualized in Xenium Explorer.

Visit the [10x Genomics Support website](#) for additional information.

Tips and Best Practices



TIPS

- 33** Handling Xenium Slide with Tissue Section
- 33** Vibration Isolation Table Specifications
- 34** Region Selection Guidelines
- 35** Reagent Buffer and Plate Preparation
- 36** Cleaning Slides and Cassette Carriers

Icons



Tips & Best Practices section includes additional guidance



Signifies critical step requiring accurate execution



Troubleshooting section includes additional guidance

Handling Xenium Slide with Tissue Section

Ensure that the Xenium Slide with the tissue sections (processed and stored as per the off-instrument workflow) is retrieved from storage just prior to loading the instrument.

- Xenium slide should be in a Xenium cassette without a lid and well filled with 1000 µl of PBS-T.



Vibration Isolation Table Specifications

Confirm that the Vibration Isolation Table gauges meet the following specifications

Vibration Isolation Table Gauge	Location	Specifications
Source air supply (Compressor, wall air, tank, etc.)	Directly in wall or where building facilities usually pre-configures	~80-150 psi
Table air supply	Right side of system that connects the wall source to vibration isolation table leg	~70-80 psi
Table leg pressure	Back left leg of vibration isolation table	~50-60 psi

If any values are out of range, contact support@10xgenomics.com for assistance

Region Selection Guidelines

During sample scanning, regions of interest must be defined prior to instrument run.

Key considerations with selecting regions

Refer to [Region Selection](#) for full list of guidelines

- The unit of selection is called a field of view (FOV). One FOV corresponds to one box in the grid.
- At least one FOV must be defined as a region. At least one region must be defined per slide. Regions do not need to be contiguous.

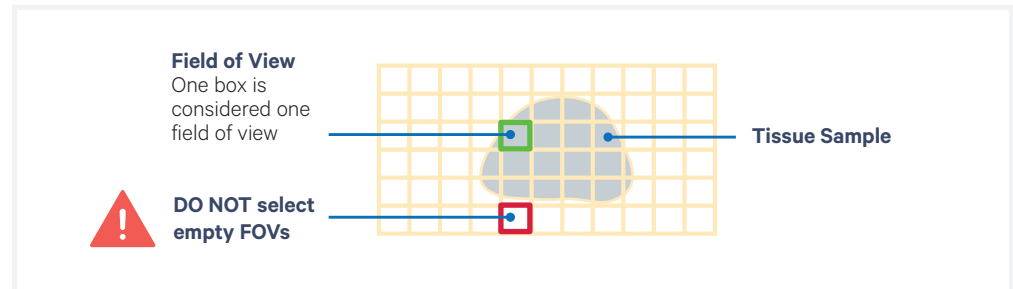

! Each FOV can only be assigned to one region and cannot be selected twice. DO NOT select empty FOVs. Selecting empty FOVs will yield stitching errors.

- Avoid including FOVs that are <5% filled with tissue in a region. Inclusion of FOVs that are mostly blank can lead to stitching and registration errors
- Region names must be unique across all slides.
- **For slides with multiple tissue sections:**
 - Select each tissue section as a separate region
 - Exclude overlapping regions. If the overlapping region is assigned to one tissue, the overlapping area can be imaged but the data will be unusable.
 - No more than 8 regions can be selected per slide. If a slide contains more than 8 sections, consolidating some of these is recommended.

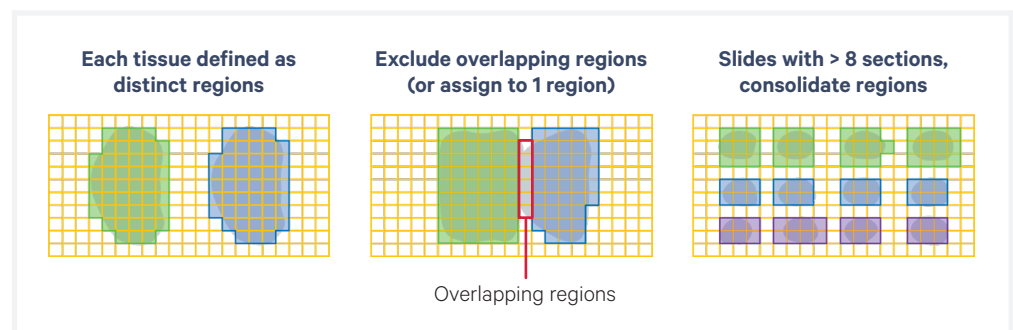

Reagent Plate and Buffer Preparation

Storing and Thawing Reagent Plates

Reagent plates are packaged in mylar bags for protection. Keep plates in mylar bag during storage and thawing. When ready to use, open the bag and remove the foil sealed plate prior to preparation for loading.

Xenium Decoding Reagent Module A and Xenium Prime Decoding Reagent Module A are stored at 4°C upon receipt and is ready to use on day of instrument. No thawing or equilibration is necessary.

Xenium Decoding Reagent Module B, Xenium Prime Decoding Reagent Module B - 5K, and Xenium Cell Segmentation Detection Module are stored at -20°C upon receipt and must be thawed at 4°C for 16-72 h prior to handling and loading onto the instrument. For same day use, thaw plate at 37°C water bath for 2.5 h in mylar packaging. Factor in the thawing step when planning an experiment.

Preparing Reagent Buffers

Reagent buffers must be prepared prior to filling the reagent buffer bottles and loading them on the instrument. Detailed instructions on how to prepare buffers are provided in [Reagent Preparation](#) section.



Buffers differ based on assay performed. Confirm the appropriate buffers are used.

Cleaning Slides and Cassette Carriers

Cleaning the bottom of the Xenium slide and the cassette carrier prior to loading the assembled cassette is critical for a successful Xenium run. Any fingerprints, lint, or liquid may interfere with image acquisition that may result in a failed run or incomplete or unreliable data generation.

Following a completed run, clean the carriers after unloading the slide, especially if liquid has leaked during the run to prevent liquid from drying onto the surface of the carrier.



- a.** Spray 70% isopropanol onto a lint-free laboratory wipe and clean the surface of the carrier, paying attention to the raised areas that come into contact with the slide. Let evaporate.
 - i.** Optional: Spray 70% isopropanol on a cotton swab and use to clean off crevices if necessary.
- b.** Use compressed air to remove any remaining lint paying close attention to raised areas. Confirm surface is dry.
- c.** Check assembled cassette to ensure the seals are not leaking liquid by blotting bottom with lint-free laboratory wipe.
- d.** Clean the bottom surface of the slide with 70% isopropanol using a lint-free laboratory wipe without spilling the storage buffer. Confirm the bottom of the slide bottom is clean and dry.



Follow local lab safety or EHS requirements for using compressed air.



A dry, clean, lint-free surface on both the slide bottom and instrument cassette carrier is critical for a proper instrument run. Any debris or lint can interfere with image acquisition.

Getting Started

- 38** Instrument Setup
- 41** Touchscreen Menu Options
- 42** Network Connectivity
- 43** Software Updates
- 46** Readiness Test
- 47** Protocol Steps & Timing

Instrument Setup

Prior to starting an experiment on the Xenium Analyzer, a series of steps must be performed to ensure proper function. The following section describes the process required to get started on the instrument.



Warning: Avoid using the Xenium Analyzer in a manner not specified by 10x Genomics. *The Xenium Analyzer has been designed to protect the user. If used improperly, the intended user protections can be impaired.*



General Power Safety

Grounding is required to prevent electric shock. If the power source is not grounded, qualified personnel must first install a reliable safety ground.

- DO NOT plug the instrument power cable into an electrical outlet if the power cable is damaged.
- To prevent electric shock, plug the instrument power cable into properly grounded outlets.
- When using an extension cable or power strip, ensure that the total ampere rating of the instrument does not exceed the ampere rating of the extension cable. The extension cable must be designed for grounded plugs and plugged into a grounded wall outlet.
- Be sure to grasp the plug, not the cable, when disconnecting the instrument from an electric socket.

Required for First-time Use Only

- Register the instrument to [10x Genomics Cloud](#).

Instrument Setup *contd.*



The user should not operate the switches at the back panel. The breaker switch and the main power switch on the back panel will be activated/used only during instrument installation and service.

Turn on the System

a. Power on the instrument using the power button (press >3 sec) on the side panel (right). See detailed information below.

- **Breaker Switch** (back right panel): Activated during installation. Not for routine user interaction. Should be kept in ON position (“I” pushed in) for normal operation.
- **Main Power Switch** (back left panel): Activated during installation. Not for routine user interaction. Should be kept in ON position (“I” pushed in) for normal operation.
- **Power Button** (side right panel): Only active when Breaker and Main Power Switch are ON (Blue LED light will be illuminated). Press the power button for **>3 sec** to initiate Xenium Analyzer and Xenium Analysis Computer power ON mode. Wait 3 minutes after powering ON before proceeding.

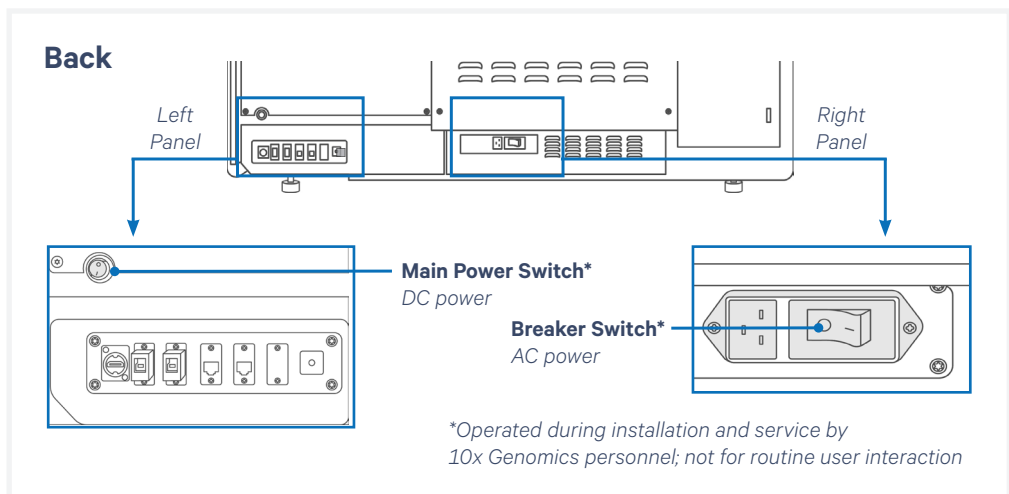
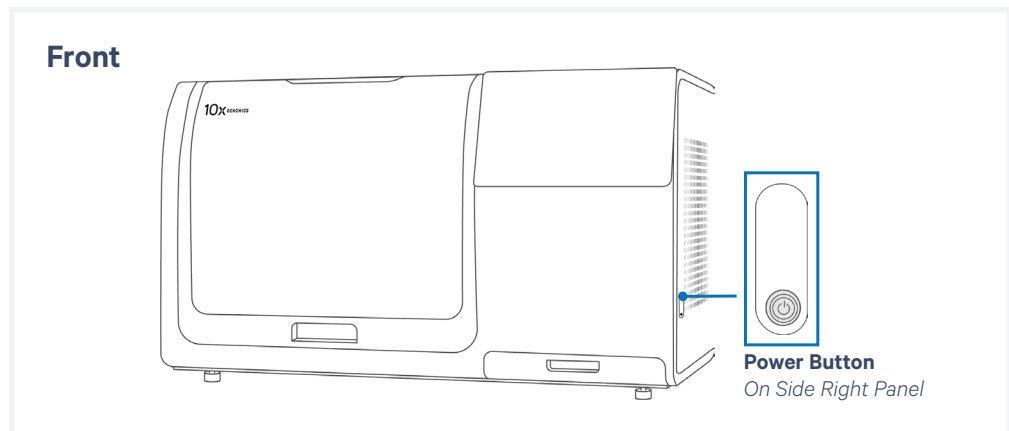

b. After the instrument powers on (~few minutes), login by selecting “Xenium User” on the touchscreen and enter password.

For first time users, a password for the user account on each instrument will be provided by 10x Genomics when the instrument is shipped. Contact support@10xgenomics.com for guidance regarding changing the password.

Instrument Setup
contd.

- c. Start the Xenium Analyzer Application by clicking the blue icon on the touchscreen. 

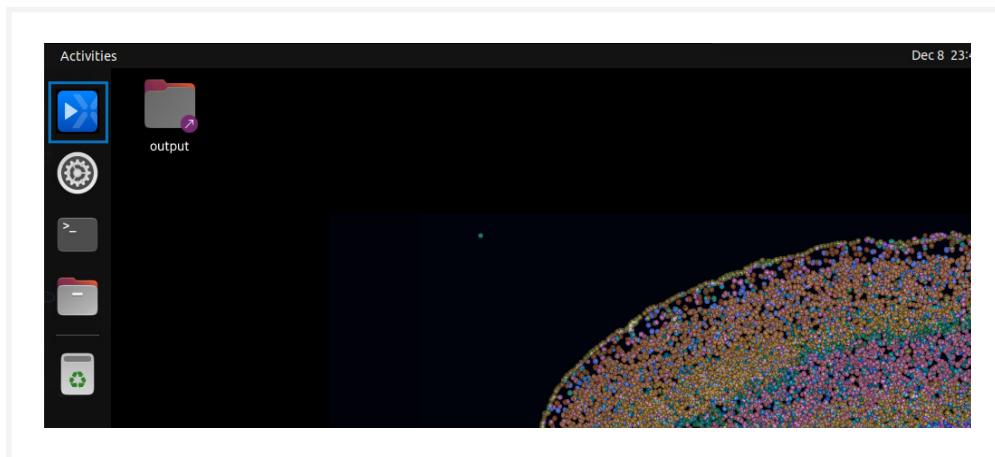

Registering the Instrument (First-time Use Only)

- a. Upon initial opening of application, a registration screen will appear. Follow the onscreen instructions to register the instrument to the 10x Genomics Cloud. When the instrument is successfully registered, the instrument home screen will appear.

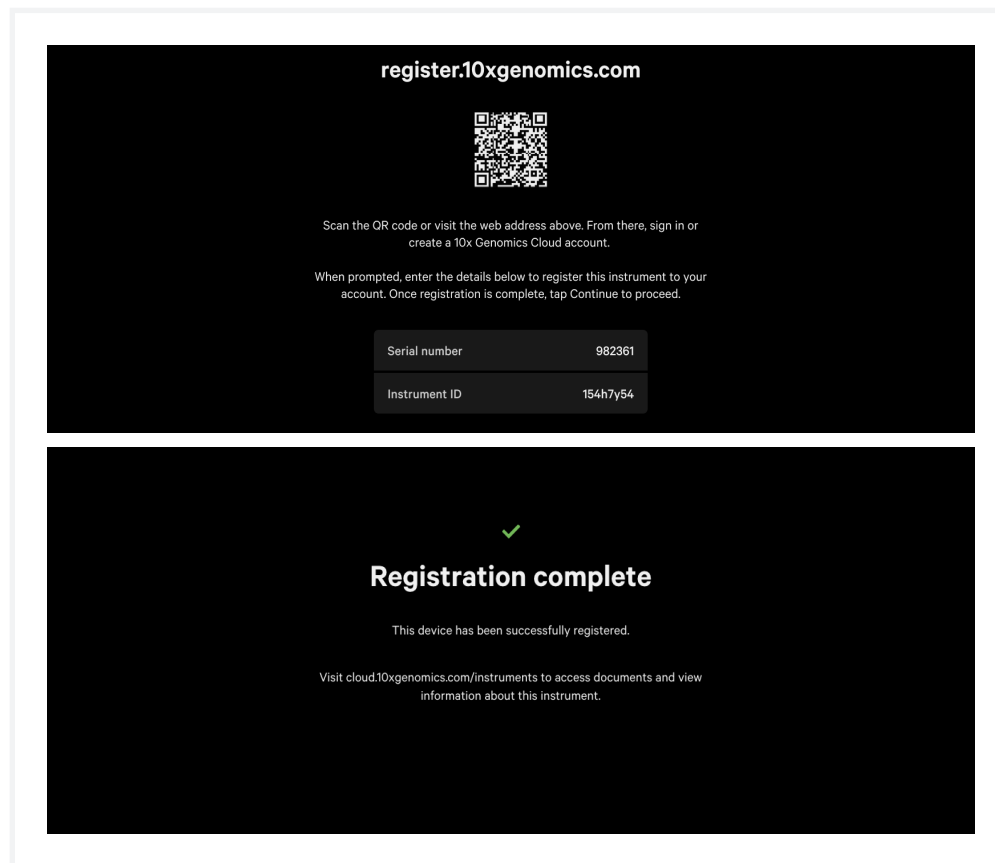

Touchscreen Menu Options

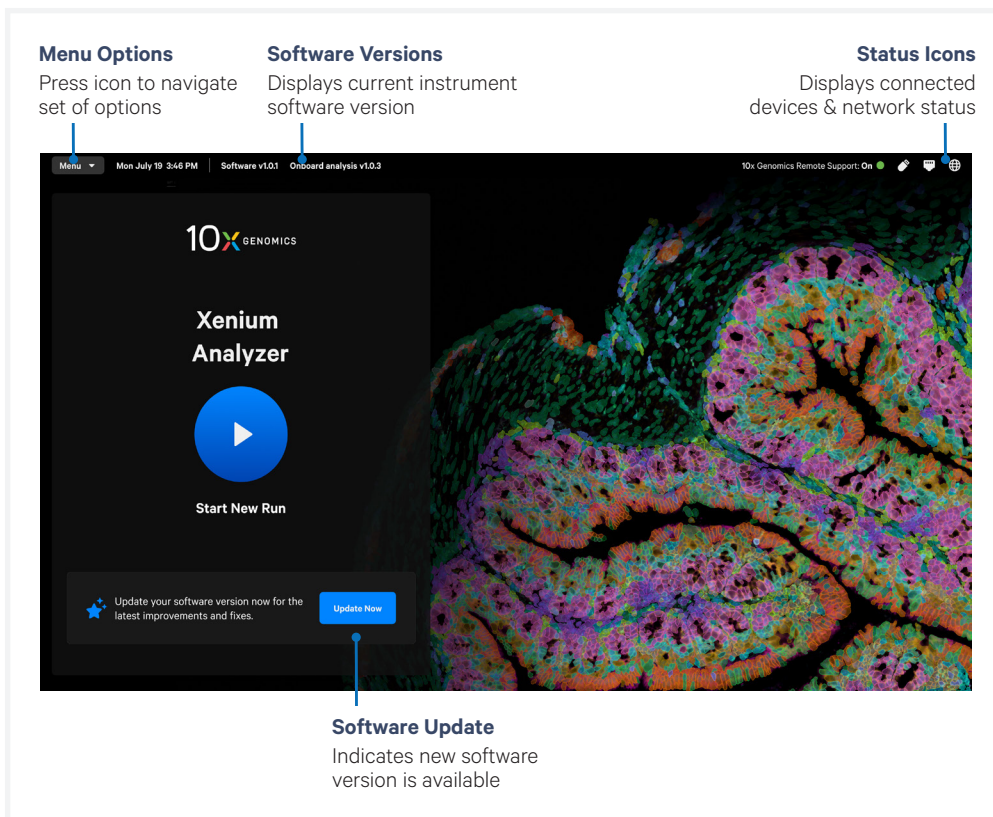

Instrument Data and Settings

Click Menu and Open Settings to access instrument information.

Run Data

- **Runs:** Runs performed on the instrument will appear here, including start date and run status. Output data from each run can be accessed here. For more detailed information on how to handle data post-run, refer to the [Data Output](#) chapter.

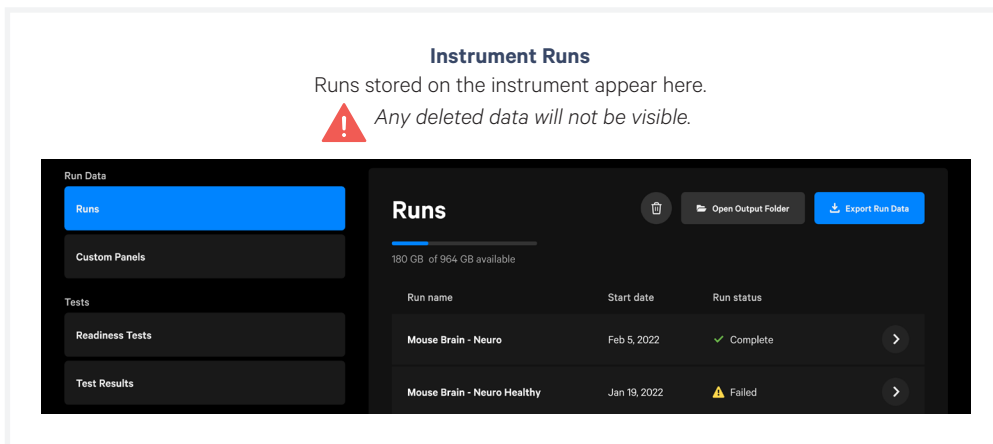

Touchscreen Menu Options

contd.

- Custom Panels: View, manage, and upload custom or add-on panels here. Only panels uploaded to the instrument are displayed.

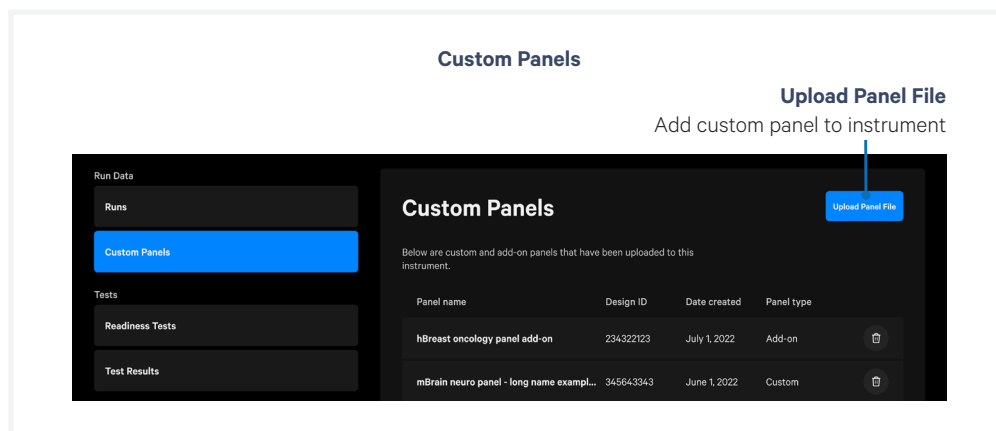

Tests

- Initiate instrument tests and view test results here. The only user run test is the Readiness Test. For detailed information on when and how to run a readiness test, refer to the [Readiness Test](#) section.



Additional types of readiness tests available on the instrument are only to be launched by 10x Field Engineers.

System

- Information about the system (including instrument serial number), analytics and privacy, and software versions are found here.

To exit settings, click the “Close” button on the top left corner of screen, or select Menu drop down at the top left and select Close settings.

Network Connectivity

Xenium Analyzer has a highly interactive user interface paired with network connectivity, intended to provide a seamless user experience along with efficient remote monitoring to optimize instrument performance. This also gives 10x Genomics the ability to respond quickly and troubleshoot any issues that may occur.

Refer to the [Xenium Analyzer Network Connectivity Guidelines Technical Note \(CG000645\)](#) for comprehensive information regarding remote performance monitoring and remote support along with additional technical details.

Software Updates

For version 1.6 or higher

Keep Xenium Analyzer Application up to date to ensure instrument can utilize the latest assay products, features, and bug fixes. Software updates may improve or alter the on-instrument analysis pipeline.



Using the latest version of the software is recommended, however changes to the pipeline may introduce batch effects if upgrades are completed between runs involved in a multi-run experiment. Refer to the [Xenium Software Release Notes](#) for details before updating.

Instrument requires Internet connection to receive notifications and perform installation.

Initiate Software Update

There are two ways to initiate a software update: from the home screen, or from the Software section of the Settings panel.

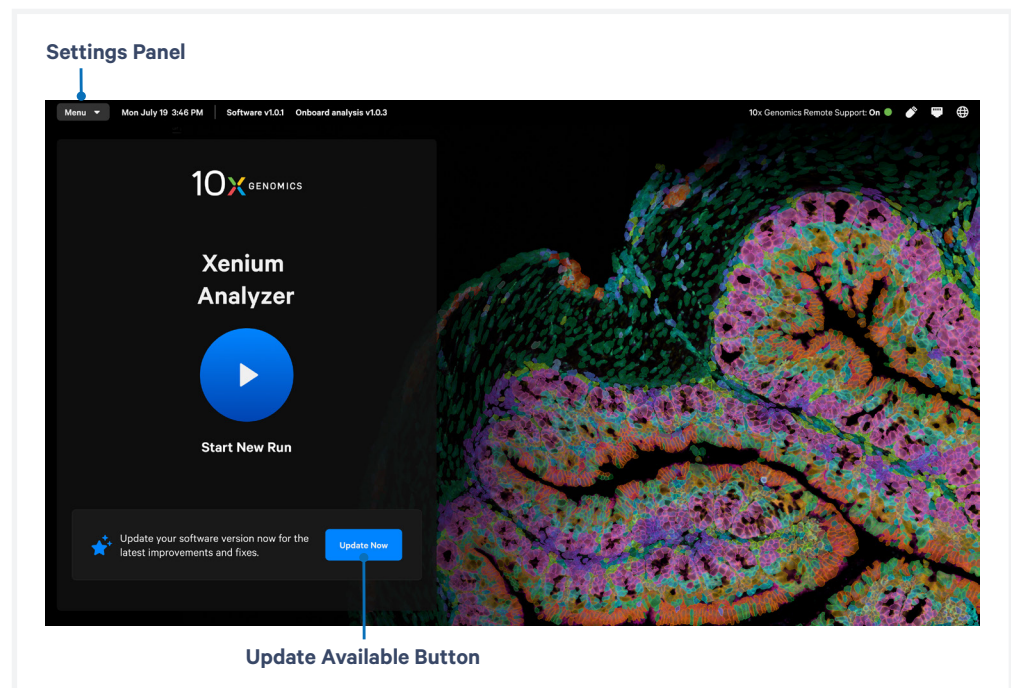

Software Updates

contd.

From Home Screen

- a. When software update is available, a blue “Update Now” button will appear. Click button and follow on screen instructions to download and install.

If Remind Me Later is selected, the Update Now message on the home screen will reappear at a later time. It is recommended to keep your system up to date to ensure latest instrument improvements and bug fixes.

From Settings Panel

- a. On the top left corner of the screen, click Menu -> Settings -> Software
- b. When software update is available, screen will say “Update available”. Click View Release Notes and Download to download update. A popup window will appear indicating the version of available upgrade and link to software release notes.
- c. Ensure “Keep this instrument up to date” is toggled ON to have updates downloaded in the background. Using this feature will not impact instrument runs.



When turned ON, updates will be downloaded in the background when available to ensure instrument remains up to date. User must still install new version.

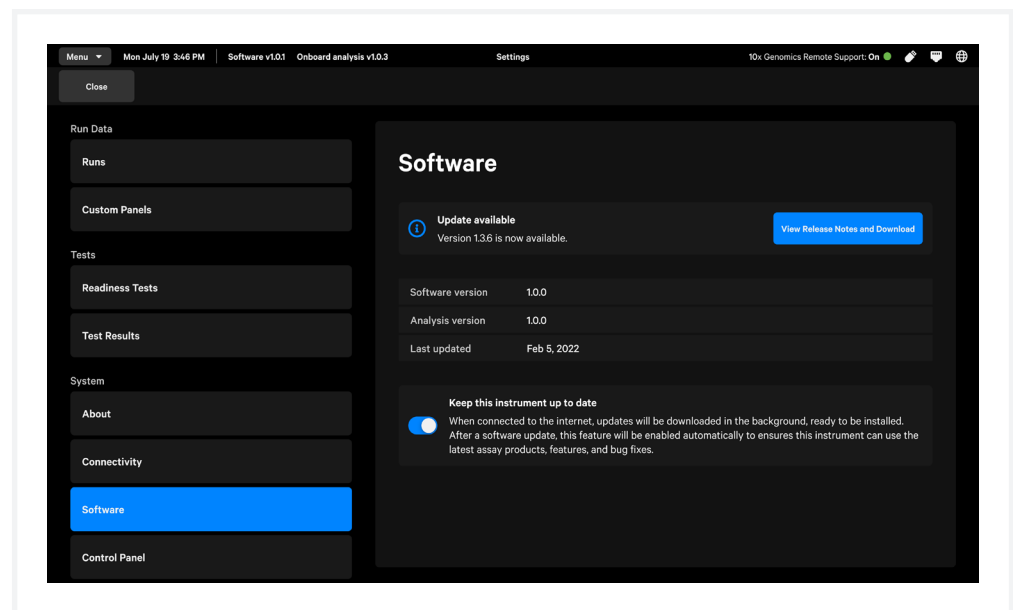

- d. Click download and install to continue with software update.

Software Updates

contd.

Installing Software Update

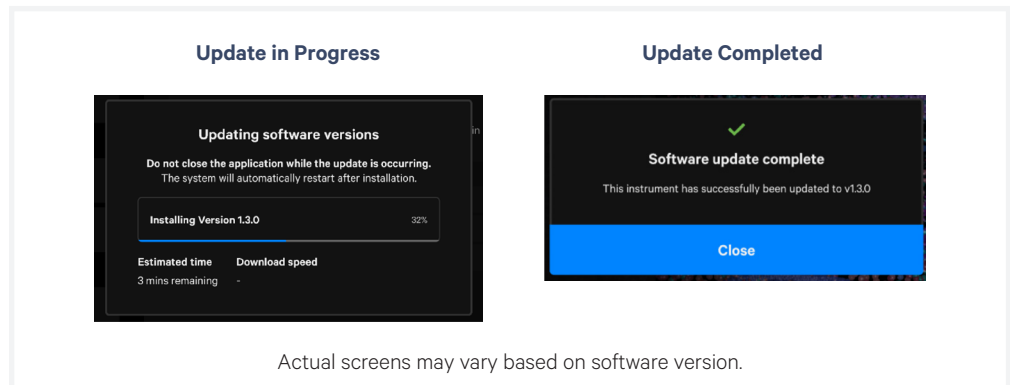

- a. During installation, a popup window will appear showing progress bar with completion percentage, estimated time remaining, and current download speed.
- b. Following installation, the instrument will be automatically rebooted and login is required.
- c. Upon opening Xenium Analyzer software, a popup window will display Software update complete, indicating successful update.

Readiness Test

The Readiness Test verifies that all systems are working optimally and the instrument is ready for use. No reagents are used (the Readiness Test is the only dry run the instrument utilizes). The Readiness Test is included as a pre-run verification for all instrument runs, but can be initiated as a standalone operation at the discretion of the end user from the Tests Menu option.

- a. To initiate the Readiness Test, select Menu (top left corner of screen) and choose Open Settings on the touchscreen.
- b. Under the Tests category, select Readiness Tests.
- c. Three types of Readiness Tests will appear. The first option, Readiness Test, is the option for end users to run. To start the test, click “Start Test” under Readiness Test.



Additional types of readiness tests available on the instrument are only to be launched by 10x Field Engineers.

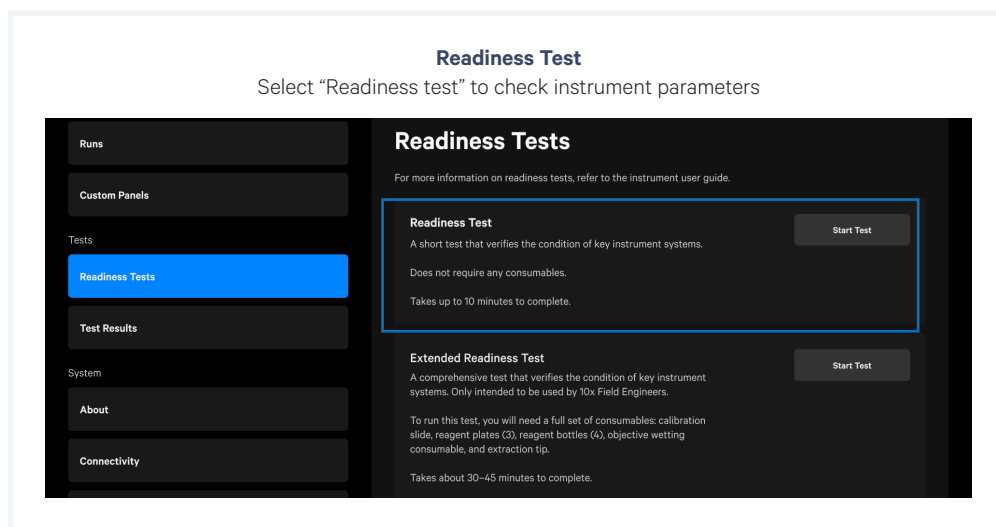

- d. A successful Readiness Test verifies the instrument is ready for use. Follow onscreen instruction in the event of a failed or incomplete test.
- e. Exit Readiness Tests screen by selecting the Close settings button at the top left corner of the screen, or select the Menu drop down and click Close settings. The home screen will appear following exiting.

Protocol Steps & Timing

(on-instrument; for both FFPE & FF samples)

For Xenium v1 Workflows

Steps	Timing	
	Hands-on Time	Total Time
Day 1		
Thaw Decoding Reagent Module B	5 min	16-72 h at 4°C*
Thaw Cell Segmentation Detection Module**	5 min	16-72 h at 4°C*
Day 2		
Prepare Buffers	1 h	1 h
Initialize Instrument	-	5-10 min
Input Experimental Details	5-10 min	5-10 min
Load Instrument	~5 min	~5 min
Sample Scan	-	1 h
Select Region & Initiate Run	~10 min	~10 min
Day 4-6		
Run Time	-	2-4 days
Post-Run Cleanup	5 min	10 min

*2.5 h at 37°C water bath for same day use

**if performing Xenium In Situ Gene Expression with Cell Segmentation Staining workflow (CG000749)

For Xenium Prime Workflow

Steps	Timing	
	Hands-on Time	Total Time
Day 1		
Thaw Xenium Prime Decoding Reagent Module B - 5K	5 min	16-72 h at 4°C*
Day 2		
Prepare Buffers	1 h	1 h
Initialize Instrument	-	5-10 min
Input Experimental Details	5-10 min	5-10 min
Load Instrument	~5 min	~5 min
Sample Scan	-	1 h
Select Region & Initiate Run	~10 min	~10 min
Day 4-8		
Run Time	-	2-6 days
Post-Run Cleanup	5 min	10 min

*2.5 h at 37°C water bath for same day use

Reagent Preparation

49 Step 1: Reagent Plate Preparation

52 Step 2: Buffer Preparation

Step 1: Reagent Plate Preparation

Gather Items

Gather the items listed in the table below. Items are grouped by workflow performed. Ensure the correct materials are obtained before proceeding.



Decoding Reagent Module B, Xenium Prime Decoding Reagent Module B - 5K, and Cell Segmentation Detection Module require overnight thawing at 4°C. Ensure plate is removed from -20°C and placed at 4°C the night prior to the instrument run.



Refer to SDS for instructions on proper handling and disposal of volatile and hazardous chemicals.

GET STARTED! Item	10x PN	Preparation & Handling	Storage
Xenium In Situ Gene Expression Workflow			
<input type="checkbox"/> Xenium Decoding Reagent Module A	1000624	-	4°C
<input type="checkbox"/> Xenium Decoding Reagent Module B	1000625	Thaw in sealed mylar bag at 4°C for 16-72 h or at 37°C for 2.5 h	-20°C
Xenium In Situ Gene Expression with Cell Segmentation Staining Workflow			
<input type="checkbox"/> Xenium Decoding Reagent Module A	1000624	-	4°C
<input type="checkbox"/> Xenium Decoding Reagent Module B	1000625	Thaw in sealed mylar bag at 4°C for 16-72 h or at 37°C for 2.5 h	-20°C
<input type="checkbox"/> Xenium Cell Segmentation Detection Module	1000639	Thaw in sealed mylar bag at 4°C for 16-72 h or at 37°C for 2.5 h	-20°C
Xenium Prime In Situ Gene Expression with optional Cell Segmentation Staining Workflow			
<input type="checkbox"/> Xenium Prime Decoding Reagent Module A	1000721	-	4°C
<input type="checkbox"/> Xenium Prime Decoding Reagent Module B - 5K	1000722	Thaw in sealed mylar bag at 4°C for 16-72 h or at 37°C for 2.5 h	-20°C
Additional Materials (all workflows)			
<input type="checkbox"/>	Empty plate (deep-well, 96 well) for counterbalancing and centrifuge that fits deep-well 96 well plates (~2 ml vol.) (<i>Allegra® X-14 Series Benchtop Centrifuge 120 V or equivalent</i>)		
<input type="checkbox"/>	Serological Pipettes		
<input type="checkbox"/>	Plate seal		
<input type="checkbox"/>	Laboratory Balance		

This list may not include some standard laboratory equipment.

Step 1: Reagent Plate Preparation

contd.

A

Decoding Reagent Module A/Xenium Prime Decoding Reagent Module A



Module A is oxygen sensitive! Keep plate in its original vacuum sealed mylar packaging during storage at 4°C.

- a. On the day of the instrument run, open the mylar packaging and remove plate with the intact foil seal. The foil seal on the plate should not be removed at any time. Mix by gently inverting the plate 20x without introducing bubbles. DO NOT vortex. Maintain on ice.



Plate must be used within 5 days (includes run time) after opening and removal from mylar packaging

- b. Prepare a plate for counterbalancing as described in the Plate Counterbalancing Instructions on the next page.
- c. Place the reagent plate and the plate for counterbalancing in a swinging bucket centrifuge. Once balanced, centrifuge at **300 rcf** for **1 min** at **room temperature**.
- d. Remove from centrifuge and place plate at **4°C** until loading. DO NOT invert the plate after centrifugation.

B C

Decoding Reagent Module B/Xenium Prime Decoding Reagent Module B - 5K/Cell Segmentation Detection Module*

*if performing Xenium In Situ Gene Expression with Cell Segmentation Staining workflow



Keep plates in its original vacuum sealed mylar packaging during storage at -20°C and during thaw at 4°C.

- a. Thaw plate in its original packaging at **4°C** for **16-72 h** or at **37°C** for **2.5 h**. Unopened plate in its original mylar packaging may be kept at **4°C** for up to **3 days**.
- b. Remove thawed plate and equilibrate at room temperature for **30 min**.
- c. Open the mylar packaging to remove plate with the intact foil seal. The foil seal on the plate should not be removed at any time. Mix by gently inverting the plate 20X without introducing bubbles. DO NOT vortex. Maintain at **room temperature**.
- d. Prepare a plate for counterbalancing as described in the Plate Counterbalancing Instructions on the next page.
- e. Place the reagent plate and the plate for counterbalancing in a swinging bucket centrifuge. Once balanced, centrifuge at **300 rcf** for **1 min** at **room temperature**.
- f. Remove from centrifuge and leave plate at **room temperature** until ready to load. DO NOT invert the plate after centrifugation.

Step 1: Reagent Plate Preparation

contd.

Reagent Plate Preparation Summary		
Step	A Decoding Reagent Module A/Xenium Prime Decoding Reagent Module A	B Decoding Reagent Module B/Xenium Prime Decoding Reagent Module B - 5K C Cell Segmentation Detection Module*
Thaw	-	Store in the sealed mylar bag at: 4°C for 16-72 h OR 37°C water bath for 2.5 h
Day of instrument run	Oxygen sensitive Remove plate from 4°C Open the mylar packaging to remove plate <i>(foil seal stays intact)</i> Mix by gently inverting the plate 20x without introducing bubbles. DO NOT vortex Maintain on ice	Remove plate from 4°C. Equilibrate at room temperature for 30 min Open the mylar packaging to remove plate <i>(foil seal stays intact)</i> Mix by gently inverting the plate 20x without introducing bubbles. DO NOT vortex Maintain at room temperature
Counterbalance	Prepare counterbalancing plate	Prepare counterbalancing plate
Centrifuge	300 rcf for 1 min at room temp.	300 rcf for 1 min at room temp.
Before loading	Maintain at 4°C	Maintain at room temperature

* if performing Xenium In Situ Gene Expression with Cell Segmentation Staining workflow

Plate Counterbalancing Instructions



Reagent and Detection Modules do not weigh the same and should be counterbalanced separately

- Weigh the Xenium module plate with elastic and lid on.
(example: 190 g)
- Place the empty counterbalancing deep-well 96 well plate on the weighing balance and using a pipette (multichannel/serological) add water to the plate wells until the total weight is equal to the Xenium module plate ± 1 g.
(example: counterbalancing plate with water=189.6 g)
- Remove from the counterbalancing plate from the weighing balance, add a seal to it, and use for counterbalancing the Xenium module plate.





Step 2: Buffer Preparation

Overview





The table below summarizes the buffers required for the instrument run. Note that Wash Sample Buffer B differs depending on assay workflow.

Reagent Bottle buffers should be prepared fresh before use. Ensure buffers are transferred to the correct Reagent Bottle as indicated in the instructions on the following pages.

For Xenium v1 Workflows

Label Color	Bottle Position	Reagent Buffer Bottle Name	Composition
	1	Deionized Water/Xenium Instrument Wash Buffer	Milli-Q Water
	2	Xenium Sample Wash Buffer A	PBS + Tween
	3	Xenium Sample Wash Buffer B	Milli-Q Water
	4	Xenium Probe Removal Buffer	DMSO + Tween + KCl

For Xenium Prime Workflow

Label Color	Bottle Position	Reagent Buffer Bottle Name	Composition
	1	Deionized Water/Xenium Instrument Wash Buffer	Milli-Q Water
	2	Xenium Sample Wash Buffer A	PBS + Tween
	3	Xenium Sample Wash Buffer B	PBS + Tween
	4	Xenium Probe Removal Buffer	DMSO + Tween + KCl

Step 2: Buffer Preparation



contd.



Refer to SDS for instructions on proper handling and disposal of volatile and hazardous chemicals.

Choose only one for Xenium Sample Wash Buffer A

Gather the items listed in the table below. For items with multiple options listed, choose an option based on availability and preference.

GET STARTED! Item	10x PN	Preparation & Handling	Storage
<input type="checkbox"/>  Deionized Water/ Xenium Instrument Wash Buffer*	3001198	-	Ambient
<input type="checkbox"/>  Xenium Sample Wash Buffer A*	3001199	-	Ambient
<input type="checkbox"/>  Xenium Sample Wash Buffer B*	3001200	-	Ambient
<input type="checkbox"/>  Xenium Probe Removal Buffer*	3001201	-	Ambient

*Empty bottles

Additional Materials

- Nuclease-free Water (not DEPC-treated) or Nuclease-free MilliQ water (Biopak® Polisher)
- PBS-Tween
OR
PBS - Phosphate Buffered Saline (10X) pH 7.4, RNase-free and Tween 20 Detergent Solution (10% solution)
- 100% DMSO
- Potassium Chloride (KCl)
- Glass Bottles with Cap (500 ml, 1 L)
- Serological Pipettes (10 ml, 25 ml, 50 ml) & Serological Pipette Controller
- Pipette Tips (1,000 µl) & Pipette
- Ultrapure/Milli-Q water

This list may not include some standard laboratory equipment.

Step 2: Buffer Preparation

For Xenium v1 Workflows

Prepare Reagent Bottle Buffers for Xenium v1

If performing Xenium In Situ Gene Expression (CG000582) or Xenium In Situ Gene Expression with Cell Segmentation Staining (CG000749), prepare the following buffers.

Prepare buffers fresh prior to setup of the Xenium Analyzer. Read all the preparation instructions for various options before proceeding.



Before preparation, sterilize glass bottles by autoclaving. Ensure bottles and caps are free of residual detergents, debris, and nuclease activity is minimized.

Measure liquids using a graduated cylinder for accuracy. A funnel may be used when pouring buffers. Ensure buffers are free of particulate material as that can clog the instrument lines.

1 Deionized Water/Xenium Instrument Wash Buffer

Fill Reagent Bottle #1 with **500 ml** of Nuclease-free Water/Nuclease-free Milli-Q Water using a graduated cylinder and cap bottle with standard bottle cap.

2 Xenium Sample Wash Buffer A

Prepare Xenium Sample Wash Buffer A in a 1 L glass bottle.

Option A Add reagents in order listed	PN	1X (amount)
Nuclease-free Water	AM9932 or CDUFBIOA1	1 L
PBS-Tween	P3563-10PAK	1 Pack
Total	—	1 L
Option B Add reagents in order listed	PN	1X (amount)
Nuclease-free Water	AM9932 or CDUFBIOA1	1 L
PBS-Tween	PPB005-20PAK	2 Packs
Total	—	1 L
Option C Add reagents in order listed	PN	1X (amount)
Nuclease-free Water	AM9932 or CDUFBIOA1	895 ml
10X PBS	AM9624	100 ml
10% Tween 20	28320	5 ml
Total	—	1 L

Step 2: Buffer Preparation

For Xenium v1 Workflows

If using Option A or B (PBS-T powder bags):

- a. Using a graduated cylinder, add 1 L Nuclease-free Water/Nuclease-free Milli-Q Water to a 1 L glass bottle.
- b. Add appropriate number of PBS-Tween powder bags to the 1 L Nuclease-free Water/Nuclease-free Milli-Q Water.



Ensure that the powder is collected at the bottom of the bag before opening.

- c. Proceed to step d.

If using Option C (preparing from 10X PBS and 10% Tween):

- a. Using a graduated cylinder, add **895 ml** Nuclease-free Water/Nuclease-free Milli-Q Water to a 1 L glass bottle.
- b. Using a graduated cylinder, add **100 ml** 10X PBS to the glass bottle.
- c. Using a serological pipette, add **5 ml** Tween-20 to the glass bottle. Ensure that Tween-20 is completely dispensed. Rinse the pipette by pulling in **~5 ml** PBS from the bottle and dispensing the entire volume back into the bottle.
- d. Cap bottle and slowly invert approximately 10x. Ensure that minimal bubbles are introduced during inversion process.



DO NOT use magnetic stir bars or vigorous shaking to dissolve the PBS-T

- e. Pour prepared buffer into Reagent Bottle #2 and cap the bottle (use the standard cap and not the Xenium Buffer Cap). If bubbles are created during mixing, wait **~30 min** or until the bubbles dissipate. Minor amount of bubbles are acceptable.

3 Xenium Sample Wash Buffer B

Fill Reagent Bottle #1 with **500 ml** of Nuclease-free Water/Nuclease-free Milli-Q Water using a graduated cylinder and cap bottle with standard bottle cap.

Step 2: Buffer Preparation

For Xenium v1 Workflows

4 Xenium Probe Removal Buffer

Xenium v1 workflow requires **300 ml** Xenium Probe Removal Buffer

Probe Removal Buffer for Xenium v1 Workflow <i>Add reagents in order listed</i>	Stock	Final	1X (ml)
Nuclease-free Water	—	—	139.5
DMSO	100%	50%	150
KCl	2,000 mM	50 mM	7.5
Tween 20	10%	0.1%	3
Total	—	—	300

Buffer may become warm during preparation.

- a. Add Nuclease-free Water/Nuclease-free Milli-Q Water to 500 ml glass bottle using a 50 ml serological pipette.
- b. Add DMSO to the Nuclease-free Water/Nuclease-free Milli-Q Water using a 50 ml serological pipette.



DMSO is hazardous and should be added to nuclease-free water inside a fume hood. Refer to SDS for instructions on proper handling and disposal.

- c. Cap bottle and invert 10x to mix.
- d. Pipette KCl into glass bottle using a 10 ml serological pipette.
- e. Slowly pipette Tween 20 into glass bottle using a p1000 pipette. Ensure all the Tween 20 is dispensed from the pipette tip.
- f. Cap bottle and slowly invert approximately 10x. Ensure that no bubbles are introduced during the inversion process.



Tween 20 may cause the Xenium Probe Removal Buffer to appear cloudy.

- g. Pour prepared buffer into Reagent Bottle #4 and cap the bottle (use the standard cap and not the Xenium Buffer Cap). Maintain the buffer at room temperature for **30 min** to cool it down and to clear bubbles created during mixing. Minor amount of bubbles are acceptable.

Step 2: Buffer Preparation

For Xenium Prime Workflow

Prepare Reagent Bottle Buffers for Xenium Prime

If performing Xenium Prime In Situ Gene Expression (CG000760), prepare the following buffers.

Prepare buffers fresh prior to setup of the Xenium Analyzer. Read all the preparation instructions for various options before proceeding.



Before preparation, sterilize glass bottles by autoclaving. Ensure bottles and caps are free of residual detergents, debris, and nuclease activity is minimized.

Measure liquids using a graduated cylinder for accuracy. A funnel may be used when pouring buffers. Ensure buffers are free of particulate material as that can clog the instrument lines.

1 Deionized Water/Xenium Instrument Wash Buffer

Fill Reagent Bottle #1 with **500 ml** of Nuclease-free Water/Nuclease-free Milli-Q Water using a graduated cylinder and cap bottle with standard bottle cap.

2 3 Xenium Sample Wash Buffer A and B

Prepare **2000 ml** of Xenium Sample Wash Buffer A and B in a 2 L glass bottle. Proceeding instructions provided are for using 2 L glass bottle. If a 2 L glass bottle is not available, make 1 L at a time.

Option A <i>Add reagents in order listed</i>	PN	1 L	2 L
Nuclease-free Water	AM9932 or CDUFBIOA1	1 L	2 L
PBS-Tween	P3563-10PAK	1 Pack	2 Packs
Total	—	1 L	2 L

Option B <i>Add reagents in order listed</i>	PN	1 L	2 L
Nuclease-free Water	AM9932 or CDUFBIOA1	1 L	2 L
PBS-Tween	PPB005-20PAK	2 Packs	4Packs
Total	—	1 L	2 L

Option C <i>Add reagents in order listed</i>	PN	1 L	2 L
Nuclease-free Water	AM9932 or CDUFBIOA1	895 ml	1790 ml
10X PBS	AM9624	100 ml	200 ml
10% Tween 20	28320	5 ml	10 ml
Total	—	1 L	2 L

Step 2: Buffer Preparation

For Xenium Prime Workflow

If using Option A or B (PBS-T powder bags):

- Using a graduated cylinder, add 2 L Nuclease-free Water/Nuclease-free Milli-Q Water to a 2 L glass bottle.
- Add appropriate number of PBS-Tween powder bags to the 2 L Nuclease-free Water/Nuclease-free Milli-Q Water.



Ensure that the powder is collected at the bottom of the bag before opening.

- Proceed to step d.

If using Option C (preparing from 10X PBS and 10% Tween):

- Using a graduated cylinder, add **1790 ml** Nuclease-free Water/Nuclease-free Milli-Q Water to a 2 L glass bottle.
- Using a graduated cylinder, add **200 ml** 10X PBS to the glass bottle.
- Using a serological pipette, add **10 ml** Tween-20 to the glass bottle. Ensure that Tween-20 is completely dispensed. Rinse the pipette by pulling in **~10 ml** PBS from the bottle and dispensing the entire volume back into the bottle.
- Cap bottle and slowly invert approximately 10x. Ensure that minimal bubbles are introduced during inversion process.



DO NOT use magnetic stir bars or vigorous shaking to dissolve the PBS-T

- Pour 1 L prepared buffer into Reagent Bottle #2 and 1 L prepared buffer into Reagent Bottle #3. Cap both bottles with standard caps. If bubbles are created during mixing, wait **~30 min** or until the bubbles dissipate. Minor amount of bubbles are acceptable.

4 Xenium Probe Removal Buffer

Xenium Prime workflow requires **500 ml** Xenium Probe Removal Buffer

Probe Removal Buffer for Xenium Prime workflow <i>Add reagents in order listed</i>	Stock	Final	1X (ml)
Nuclease-free Water	—	—	232.5
DMSO	100%	50%	250
KCl	2,000 mM	50 mM	12.5
Tween 20	10%	0.1%	5
Total	—	—	500

Buffer may become warm during preparation.

Prepare buffer using instructions on page 56.

System Operation

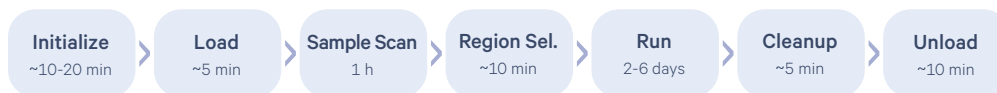

- 60** Initialize Instrument
- 63** Load Consumables
- 71** Sample Scan
- 74** Region Selection
- 75** Initiate Run
- 76** Post-run Cleanup
- 77** Unload Consumables
- 80** Powering Off Instrument

Initialize Instrument

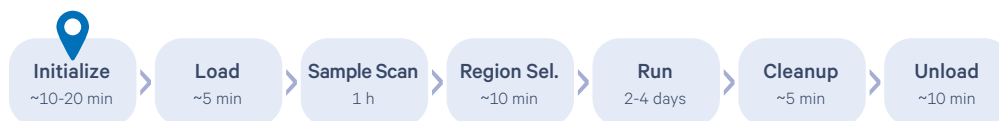

Detailed instructions below are for Xenium Onboard Analysis Software version 3.0 or higher. Screens may differ in previous versions. Follow on screen instructions.

- a. Turn on the instrument using the power switch at the side panel (right) of the instrument.
- b. *If not already open*, launch the Xenium Analyzer Application by clicking the blue icon  the touchscreen.
- c. Click “Start New Run” button.
 - A series of automated system checks will be performed by the instrument to verify that all systems are working correctly (~3 min).
- d. Input Run Name. Run name can contain maximum 33 characters and cannot contain !@#\$%&*+=
- e. **Performing Xenium Prime.** Select whether sample was prepared with Xenium Prime Reagents.
(*Software version 3.0 or higher required for Xenium Prime.*)
 - Select Yes if samples were prepared using Xenium Prime In Situ Gene Expression with optional Cell Segmentation Staining User Guide (CG000760).
 - Select No if samples prepared using Xenium In Situ Gene Expression User Guide (CG000582) or Xenium In Situ Gene Expression with Cell Segmentation Staining User Guide (CG000749).
- f. **Performing Multimodal Cell Segmentation.** Select whether sample was prepared with the Xenium Cell Segmentation Staining Reagents for multimodal cell segmentation
(*Software version 2.0 or higher required for multimodal cell segmentation.*)
 - Select Yes if samples were prepared using Xenium Prime In Situ Gene Expression with optional Cell Segmentation Staining User Guide (CG000760) and performing cell segmentation staining or Xenium In Situ Gene Expression with Cell Segmentation Staining User Guide (CG000749).
 - Select No if samples prepared using Xenium In Situ Gene Expression User Guide (CG000582)



Ensure correct selection is made. All downstream instrument functions will be affected.



Failure to select multimodal segmentation will default to nuclear expansion and multimodal data will not be recoverable.

For samples prepared using CG000749, selecting multimodal segmentation without loading plate in deck position C will lead to run failure and sample will not be recoverable.

Initialize Instrument
contd.

- g. Onboard Analysis Version.** For Xenium v1 assays, user can select Version 3.0 or Version 2.0 for instrument run. Running the latest version is recommended. However if data comparison to past runs using previous versions is desired, version 2.0 is available to select.

Xenium Prime requires software version 3.0 and therefore cannot be changed.

- h. Add Cassette Details.** If using only one slide, either of the two cassette carriers may be used.

Cassette Details

Panel Information
Will appear after panel is uploaded

Select or Upload Panel
Choose either pre-designed or upload custom panel. For custom panels, Design ID on tube label should match filename)

- i. Cassette Name** (used to reference data from this cassette) Cannot contain !@#\$%&*+=
- ii. Xenium Slide ID** (7-character ID found on the bottom short edge of the slide)



Initialize Instrument

contd.

i. Select Panel

Only panels compatible with the assay workflow chosen on assay configuration page are available to select. Click Back to revise if necessary.

- i. Click "Select of Upload a Panel"
- ii. **To select a pre-loaded panel**, expand the drop down menu to select a Pre-designed or pre-loaded Custom panel. Confirm desired panel is selected and click "Continue". Panel information under Panel Selection will populate.
- iii. **To upload a new custom panel from USB drive**, insert USB into USB port on the Xenium Analysis Computer. Click "Upload" on instrument touchscreen and select panel file. Confirm desired panel is selected and click "Continue". Panel information under Panel Selection will populate.



If using a custom panel, the Design ID on the label of the tube containing the custom panel should match with the first portion of the custom gene panel electronic file name.



The Xenium Analyzer is compatible with exFAT file systems. See [Data Output](#) chapter for additional details.

- iv. **Eject USB drive** Click Menu at the top left corner of screen and select "Minimize application" to minimize the UI screen. On the desktop, open Files and locate the USB device in the sidebar. Right-click the name of the USB and select Safely Remove Device. Remove USB from computer. Click the Xenium Analyzer application icon to return to the UI screen. On the top gray toolbar, click View and select Toggle Full Screen to display in full screen mode.

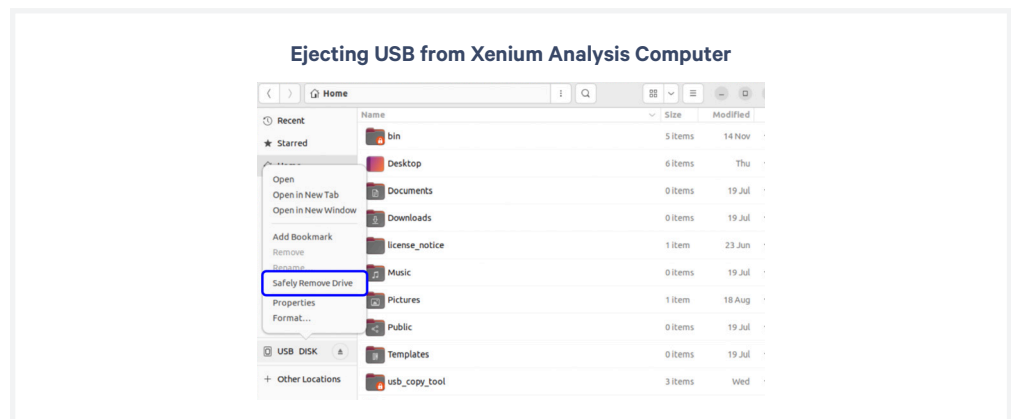

- j. If running two cassettes, load panel for remaining cassette. When all the information is populated, click "Continue".

Load Consumables



See Troubleshooting section for guidance if any errors occur during loading consumables.

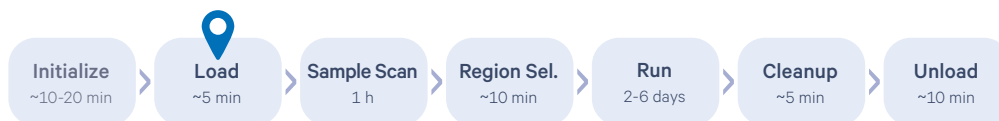

Open the front panel. Follow touchscreen instructions for loading.

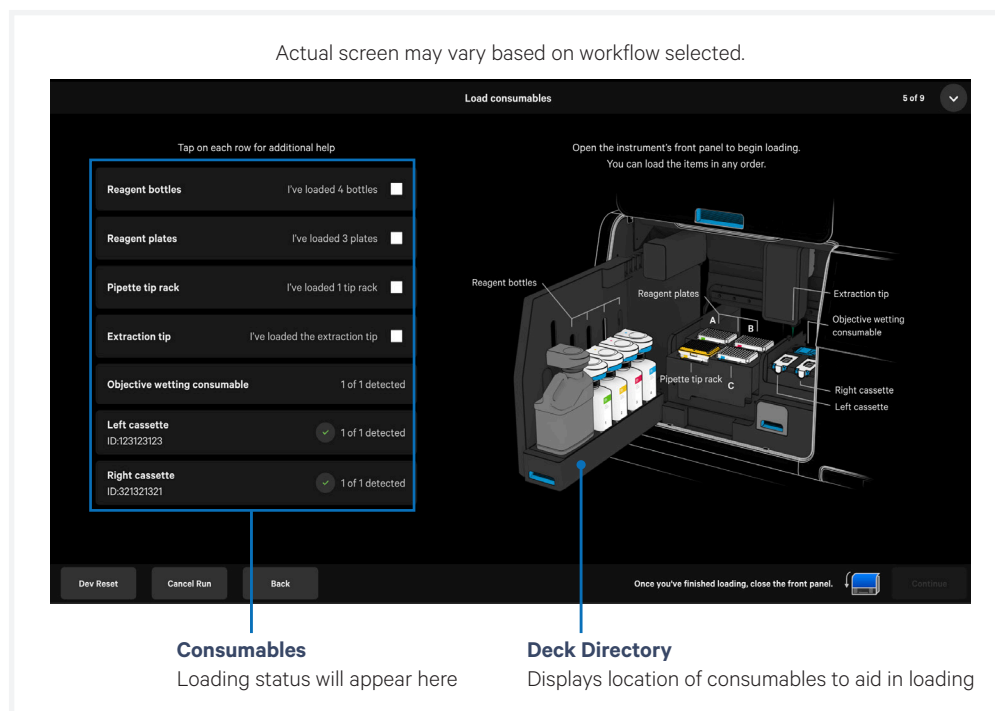

To aid in efficient and complete loading, the status of each item is shown on the left side of the screen and its location within the instrument deck is depicted on the right.

Gather all items listed below and load them as per instructions provided. All the items must be loaded correctly to begin the instrument run.

TIPS Click each row on the touchscreen to view detailed help and instructional animations.

- Cassette/s (with tissue sections on the Xenium Slide ready for the instrument run)
- Objective Wetting Consumable*
- Reagent bottles with buffer ([Reagent Preparation](#) section) + Xenium Buffer Caps*
- Reagent Plates ([Reagent Preparation](#) section)
- Pipette Tip Rack*
- Extraction Tip*

*In Xenium Decoding Consumables Kit, PN-1000487

Load Consumables contd.

Cassette



Load cassette first to avoid dust or debris moving into other areas of instrument.

- a. Squeeze the release buttons to unlatch the cassette carrier. The right button will move while the left button is static.

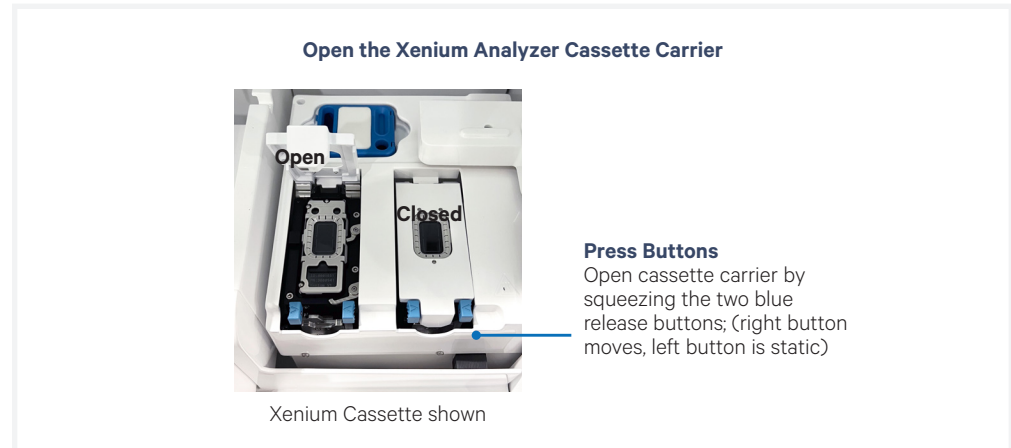

- b. Clean the cassette carrier. Spray 70% isopropanol onto a lint-free laboratory wipe and clean the surface of the carrier, paying attention to the raised areas that come into contact with the slide. Let evaporate.
 - Optional: Spray 70% isopropanol onto a cotton swab and use to clean off crevices if necessary.
- c. Use compressed air to remove any remaining lint paying close attention to raised areas. Confirm surface is dry and free of lint.
- d. Retrieve the assembled Xenium Slide Cassette(s) (processed as per Xenium In Situ Gene Expression User Guide CG000582).
- e. Check assembled cassette to ensure the seals are not leaking liquid.



See the [Troubleshooting](#) section to fix leaking cassette assembly.

- f. Clean the bottom of the slide surface with 70% isopropanol using a lint-free laboratory wipe without spilling the storage buffer. Confirm the bottom of the slide bottom is clean and dry.



A dry, clean, lint-free surface on both the slide bottom and instrument cassette carrier is critical for a proper instrument run. Any debris or lint can interfere with image acquisition.

- g. Confirm that the slide ID on the slide matches the ID number shown on the touchscreen.



Follow local lab safety or EHS requirements for using compressed air.

Load Consumables
contd.

- h. Remove the lid from the cassette. **DO NOT** spill or remove PBS-T covering the slide to ensure that the sections do not dry up.

Save lid if storing the cassette assembly post-run.

Xenium Cassette Lid Removal

Xenium Cassette Lid (CG000582 and CG000749)

1

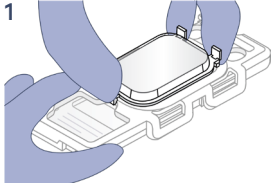

Push the upper two tabs with index and middle fingers and lower tab with thumb.

2

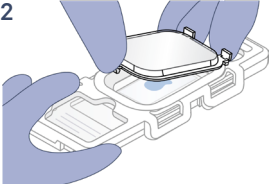

While maintaining inward pressure, pull upward with thumb until lower clip disengages.

Xenium Cassette Lid v2 (CG000760)

1

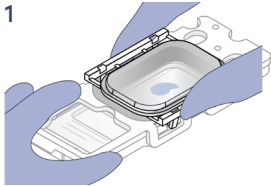

Apply even pressure on both sides of the lid using thumb and index finger.

2

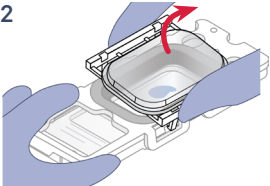

While maintaining inward pressure, pull upward with index finger to unhook the side feet from the cassette.

3

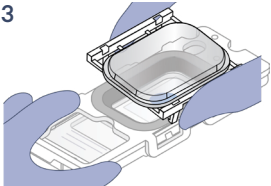

Slowly lift cassette lid up to unhook the remaining lid feet. Ensure no liquid splashes out of the well

- i. Open the cassette carrier lid fully. Place the cassette into the carrier. The top left notch on the assembled cassette aligns with the instrument. Ensure cassette is lying completely flat in the carrier.

 *Failure to load cassette properly will result in slide breaking when the lid is closed. Ensure cassette is loaded correctly prior to closing carrier lid to avoid damage.*

Proper Loading of Assembled Cassette in Instrument

Notch Alignment

Align notches on slide cassette with raised areas on the instrument (3 areas denoted by blue circles)

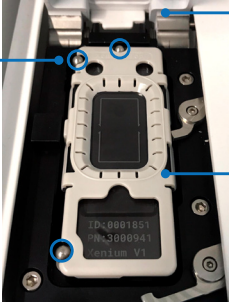

Carrier Lid Open

Open carrier lid fully before loading slide cassette

Slide Cassette Completely Flat

Ensure slide cassette is sitting flat before closing

Xenium Cassette shown

Load Consumables

contd.

- j. Close the cassette carrier lid until it clicks into place.
- k. Repeat for the Right Cassette.

Objective Wetting Consumable (OWC)

- a. Place a new OWC behind the cassette carrier with the reagent priming reservoir on the left.



Reagent Bottles

- a. Uncap the reagent bottles that were prepared earlier in the [Buffer Preparation](#) section. Recap each bottle with a Xenium Buffer Cap (included in the Xenium Decoding Consumables kit). This cap is required for loading onto the instrument.

Xenium Buffer Cap

(included in the Xenium Decoding Consumables kit)

For each reagent bottle, replace the standard reagent bottle cap with a Xenium Buffer Cap prior to loading onto the instrument







Load Consumables
contd.

b. Place each bottle within the bottle carrier in the designated order.

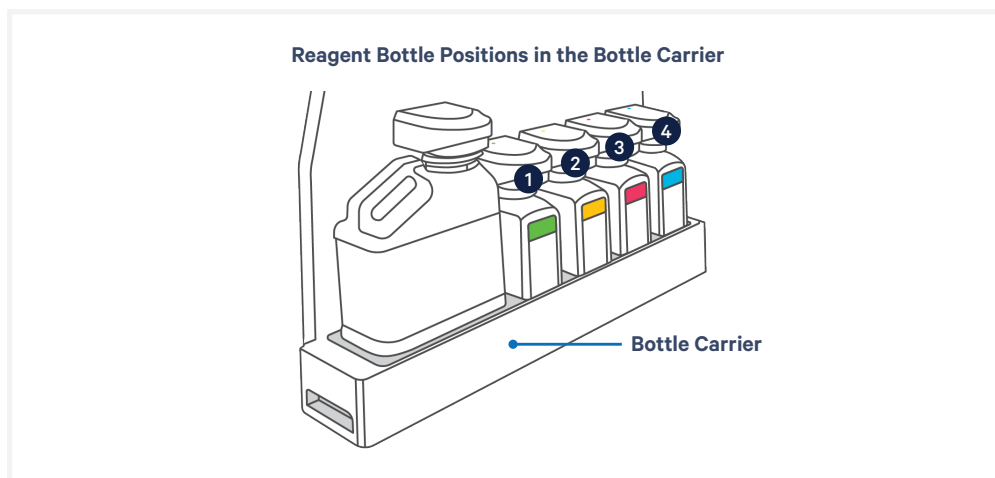

Bottle position is color and number coded. Color is indicated on top of bottle carrier cap and number is labeled on the bottle carrier itself. Match bottle position color and number with label on reagent bottle for accurate placement. Incorrect placement will result in a failed instrument run.



Color (on Bottle and Instrument)	Bottle Carrier Position	Reagent Bottle Buffer
	1	Deionized Water/Xenium Instrument Wash Buffer
	2	Xenium Sample Wash Buffer A
	3	Xenium Sample Wash Buffer B
	4	Xenium Probe Removal Buffer

c. Push the bottle carrier caps down to the top of the bottles to seal.



If the instrument screen does not show the presence of the loaded bottles, use a firm downward pressure on the bottle carrier caps to enable detection.

d. Ensure that the Waste Bottle on the left side of the instrument has been emptied and the empty uncapped Waste Bottle has been placed in the first position (closest to user). Push the bottle carrier cap down to the top of the Waste Bottle to seal.

e. Push the bottle carrier back into place.

Load Consumables *contd.*

Reagent Plates

Number of plates depends on assay performed. Touchscreen instructions will reflect correct number based on assay selected. Ensure all required plates are loaded.

- a. Remove elastic and lid from reagent plates.
- b. Place the reagent plates (prepared earlier in the [Reagent Plate Preparation](#) section) into their respective positions. Label and notches face the user. Firmly press plates down, and rock gently back and forth as needed, until plates are completely level.

 Confirm that the plate labels face the user when placed into deck and the correct plate is placed in the correct location. Improper placement will result in a failed run.



Load Consumables

contd.

Pipette Tip Rack

- Place a new pipette tip rack directly into the lower left position on the plate deck with the A1 tip position in the top left corner.
- Lower rack straight down and push down firmly on the bottom right corner until you hear a click. Make sure it is sitting flat and level inside the plate deck.
- If it is slanted or not secure, remove and place again. Remove the pipette tip rack lid.



The bottom of the tip rack position on the plate deck is lined with a black mold that aligns with the bottom of the pipette tip rack. Tip rack should fit flat and snug in place when proper alignment is achieved.



Pipette tip rack should align with Reagent Plates. Confirm after placing tip rack in place and adjust plates if necessary. Improper placement will result in a failed run.

Confirm Reagent Plates and Tip Rack Loading*

CORRECT

All reagent plates are level with tip rack



INCORRECT

Reagent Plate A is not level with tip rack (white arrow)



*Ensure tip rack is seated correctly for accurate comparison

Extraction Tip

- Align Extraction Tip into extract axis head and push tip up firmly. The tip should fit securely on and not feel loose or fall out.

Waste Tip Tray

- Ensure that the Waste Tip Tray has been emptied. To empty the tray, slide the waste tip drawer open, empty the tray, place it back in the tray and push the waste tip drawer to close.

Load Consumables *contd.*

Confirm All Consumables Loaded

Consumables Detected
Actual screen may vary based on workflow selected.

Success

Green check indicates successful loading of specific consumable

User Confirmation

User must manually click check box to confirm specific consumable has been loaded

On the touchscreen, visually and manually confirm all consumables are loaded correctly and click "Continue". Close the instrument front panel.

The instrument will verify that all consumables are loaded properly before proceeding to the next step.



If any consumable is not detected, an error message will appear. To address, open the front panel, reload necessary consumable(s), close the front panel and click "Continue".



Only the presence or absence of consumable is detected. Correct placement for reagent bottles and reagent plates in the right locations is not detected. Double check the correct placement of these consumables before continuing. Improper placement will result in a failed instrument run.



See the [Troubleshooting](#) section for guidance on resolving errors during loading consumables; includes guidance on how to open the front panel to access the instrument deck prior to starting a run.

Sample Scan

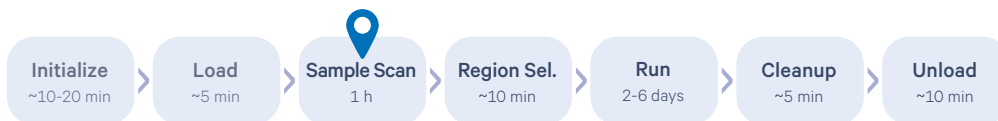

- a. Following successful loading, the instrument will begin Sample Scan during which an initial image of each slide is taken by the instrument. The image will be used for region selection.



Xenium Analyzer is sensitive to vibration. Ensure sources of vibration are kept away from the instrument during the scan.

DO NOT interact with the instrument during the scan; avoid touching the keyboard and trackpad. The front panel of the instrument remains locked during and after Sample Scan.

- b. Once Sample Scan (~1 h) is complete, click “Continue”. The sample area and related options are shown after overview scan is complete.



Fine-tuning and reviewing sample scan image at this step will help with region selection.

Overview Scan
Layout and features seen following completion

Region Selection Guidance
Instructions to properly select regions

Options Panel

Toggle views on/off and adjust channels

Sample Area

Shows image of scanned sample

Region Information

View, add, edit or delete regions

Sample Scan
contd.

- c. Review sample scan image. Use the panel on the left side of the screen to turn on/off channels, adjust channel levels, and view overlays.

Overview Scan Image Options
Left panel on screen after overview scan is completed

Channels
Check/uncheck box to turn on/off. Click ^ to show/hide Channel level

Overlays
Turn on/off grid denoting FOVs (Grid) and current region selection (Region)

Channel Level
Adjust contrast using blue slider bar



To better define tissue morphology prior to region selection, fine-tune intensity and toggle channels on/off as needed. Histogram shows number of pixels at different intensity values. Adjust slider to optimally gate a suitable threshold for pixel intensity. Tissue can appear different depending on the threshold.

Channel Levels
Adjusting channel levels can alter image significantly.*

*For visualization purposes only. Channel levels set does not impact image acquisition during run.

Sample Scan contd.

- d. Check sample autofluorescence by selecting the Yellow (Autofluorescence) channel.



While the yellow channel can aid in morphology identification, for tissues with inherent low nuclear signal, the overlay may mask tissue morphology. Ensure the channel slider is fine-tuned for the sample intensity.



High levels of autofluorescence in overview scan is likely due to tissue morphology. Proceed with instrument run even if observed. Overview scan image is not directly comparable to data outputs.

- e. Confirm sample overview scan image is free of debris.



Initiating a run with debris may further compromise image performance.

If significant debris is visible, DO NOT proceed with run. Contact support@10xgenomics.com for further instruction

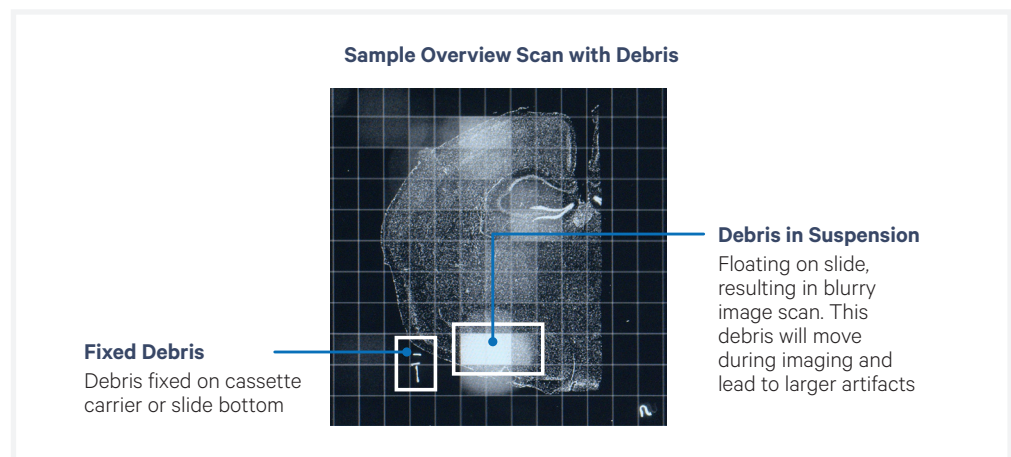

Region Selection

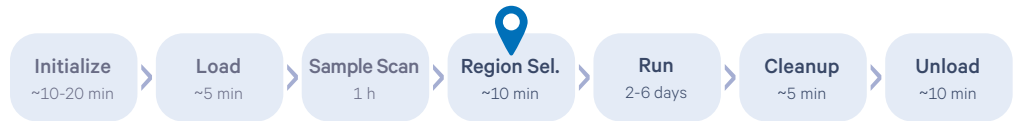

a. Click “Add Region” to designate imaging area(s) for each slide cassette.

TIPS Each grid box is one field of view (FOV). FOV can only belong to one region selection and cannot be split or selected multiple times.

! When selecting a region, **deselect all the blank FOVs**. Including blank FOVs will yield stitching errors.

b. Follow the guidelines for region selection. (Click “?” icon on top right bar to view key instructions)

Guideline	Example	
At least one region must be selected per slide. Region selection size: <ul style="list-style-type: none"> • Minimum: one FOV* • Maximum: entire well 	Minimum size (one FOV) 	Maximum size (entire well)
User defines number of tissue in each region. ! Sub-tissue section selection is not recommended		
Consolidating regions is recommended for slides with multiple sections Deselect blank FOVs. ! No more than 8 regions can be selected per slide	✓ Correct 	✗ Incorrect
If unsure which tissue sections belong together, select all the sections as one region. Deselect blank FOVs.		
FOVs in a region do not need to be contiguous.		
Overlapping regions is not possible . If tissue sections overlap, exclude overlapping areas from either region.	✓ Correct Overlapping regions Do NOT select	✗ Incorrect

TIPS Region names must be unique across all slides and contain only alphanumeric characters. Click pencil icon in the Regions window to edit. Region names are used to name the output directory, in the analysis summary HTML, the metrics_summary.csv, and the experiment.xenium.

Initiate Run

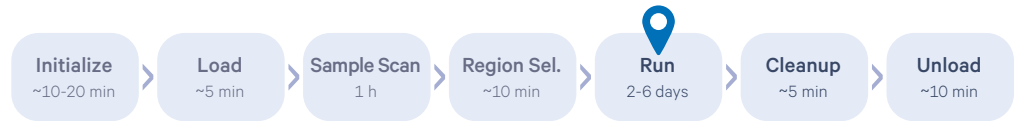

- a. Confirm consumables loaded, run settings and cassette details on the instrument screen.
- b. Click “Start Run”.



Xenium Analyzer is sensitive to vibration. Ensure sources of vibration are kept away from the instrument during the run.

DO NOT interact with the instrument during the run; avoid touching the keyboard and trackpad.

Touchscreen will display run progress and estimated time remaining. To cancel run at any time, click the “Cancel Run” button at the bottom left corner of the screen. Run information is shown in the following colors:

- **Blue** indicates run in progress.
- **Green** indicates completed run.
- **Yellow** indicates that the run is incomplete.
- **Red** indicates that the run has failed.



Refer to the [Troubleshooting](#) section for the types of errors that may be encountered when operating the Xenium Analyzer. The instrument touchscreen will guide the user through recoverable errors. If the error continues or if the instrument has seen critical errors, contact support@10xgenomics.com with the error code displayed on the screen.

Post-run Cleanup

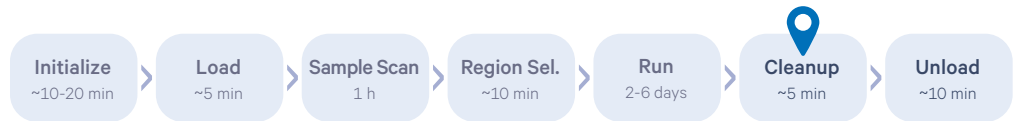

- a.** After run completion, a button will appear to initiate cleaning of fluidic system. To launch, click “Start Cleanup”.



Cleanup should be initiated within 72 h after a run is completed.

Cleanup will stop slide hydration. Follow instructions described in the Unloading Consumables section for how to store slides following cleanup.

- b.** System cleanup will begin. Screen will display progress and estimated time remaining. This process should take ~5 min.
- c.** Click “Next” when complete.

Unload Consumables



Refer to local and institutional guidelines for proper handling and disposal of volatile and hazardous chemicals.



See Troubleshooting section for guidance if any errors occur during unloading consumables.

Open the instrument front panel, remove consumables and discard solid and liquid waste. Consumables can be unloaded in any order.

If performing Xenium In Situ Gene Expression with Cell Segmentation Staining workflow, UI screen will indicate discarding three plates. If not, two plates will be stated.

Unloading Consumables
Manually check box after unloading consumable

Actual screen may vary based on workflow selected.

Cassettes & Slides



Follow local lab safety or EHS requirements for using compressed air.

a. Squeeze the release buttons to unlatch the cassette carrier and open the lid.

b. Remove the cassettes and clean the cassette carrier if necessary.

If liquid has leaked onto the carrier during instrument run, use a lint-free laboratory wipe with 70% isopropanol and compressed air to clean the surface of the carrier. Ensure no liquid remains to prevent it from drying onto the carrier surface.

c. Close the cassette carrier lid until it clicks into place.

d. Post-run, remove the liquid covering the slide, and add **750 µl** PBS-T to cover the sections in the cassette. Reapply the lid, and store at **4°C** for up to **1 week**.

*(Optional) **If performing post-run H&E,** refer to the Xenium In Situ Gene Expression - Post-Xenium Analyzer H&E Staining Demonstrated Protocol for Quencher Removal followed by H&E staining (CG000613).*

Unload Consumables

contd.

Waste Bottle (Reusable)

- a. Slide the bottle carrier tray out on the left side of the instrument.
- b. Remove the liquid Waste Bottle and discard the liquid. Each run will generate ~300-500 ml liquid waste.



The waste includes potentially volatile and hazardous chemicals. Follow institution or local guidelines for proper waste disposal.

- c. Place the empty bottle back in first position of bottle carrier.

Reagent Bottles

- a. Squeeze the bottle carrier caps and raise them until they reach a height tall enough to remove bottles.
- b. Remove bottles from carrier. Uncap the reagent bottle cap and empty the used reagent bottles at the appropriate liquid waste disposal following institution or local guidelines.



Xenium Probe Removal Buffer (blue label, bottle position 4) includes potentially volatile and hazardous chemicals. Follow institution or local guidelines for proper waste disposal.

- c. Push the bottle carrier back into place.

Objective Wetting Consumable (OWC)

- a. Remove the OWC from behind the cassette carrier.
- b. Discard the used OWC following institution or local guidelines for proper waste disposal.

Reagent Plates

- a. Remove the used reagent plates from the plate deck.
- b. Discard the used reagent plates following institution or local guidelines for proper waste disposal.



Condensation under reagent plates post-run may be visible and is normal. Following plate removal, dry the area if condensation has occurred.

Unload Consumables

contd.

Pipette Tip Rack

- Remove the tip rack from the plate deck.
- Discard tips following institution or local guidelines for proper waste disposal.

Extraction Tip

- Grip the top part of the Extraction Tip, twist it slightly in counterclockwise direction and then pull the tip down to remove.

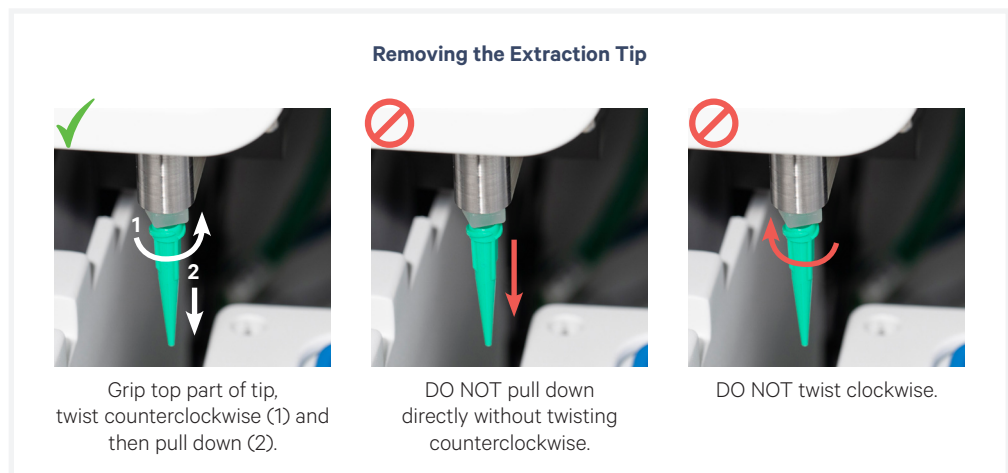

- Discard the Extraction Tip following institution or local guidelines for proper waste disposal.

Waste Tip Tray (Reusable)

- Slide the waste tip drawer open and remove the Waste Tip Tray.
- Discard the used pipette tips following institution or local guidelines for proper waste disposal.
- Place the empty Waste Tip Tray into the waste tip drawer and close.

Once all consumables are removed or emptied, close the instrument front panel and click “Continue”.

Powering OFF Instrument

While instrument shutdown is not required, user may power off instrument if it is expected to be idle for long periods of time.

- a. Retrieve data from instrument following completed run (Refer to [Data Output](#) for instructions)
- b. Press the blue power button for >3 sec located on the side panel (right)



Do NOT switch off power buttons at the rear of the instrument. Do NOT use the Touchscreen to shutdown instrument.

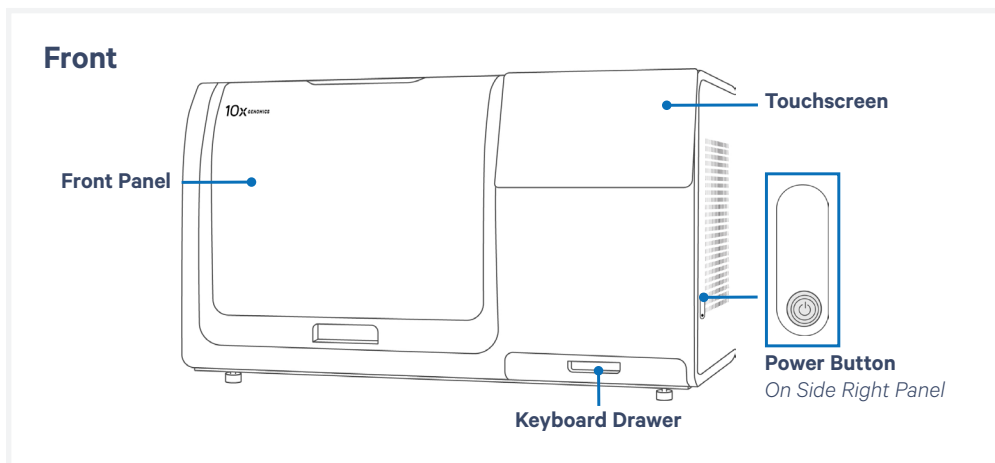



Data Output

Data Output

During every Xenium Analyzer run, image processing, decoding, and secondary analysis are performed real time on-instrument, generating a run-specific data output folder.

Data Output Location

The output data location and transfer instructions are available on the instrument screen during run setup and after the run completes.

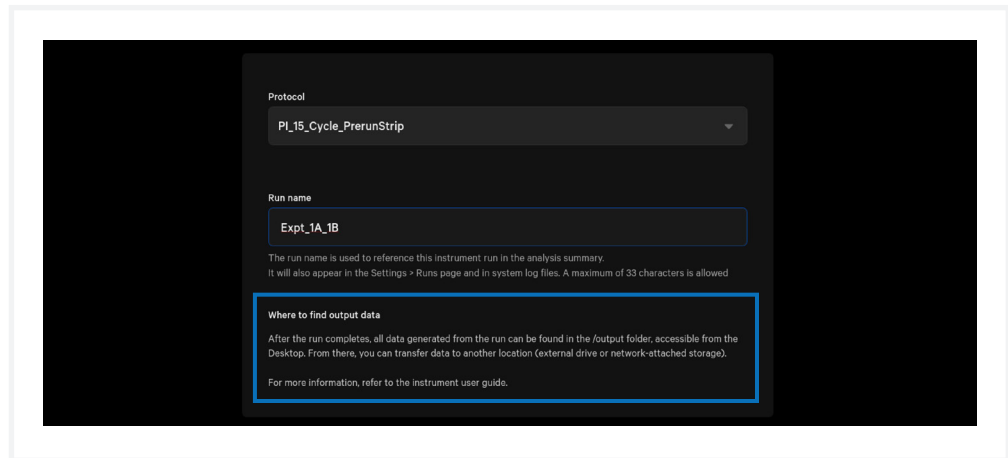

After the run is complete, data generated across all the runs can be accessed under “Menu > Open Settings > Runs”.

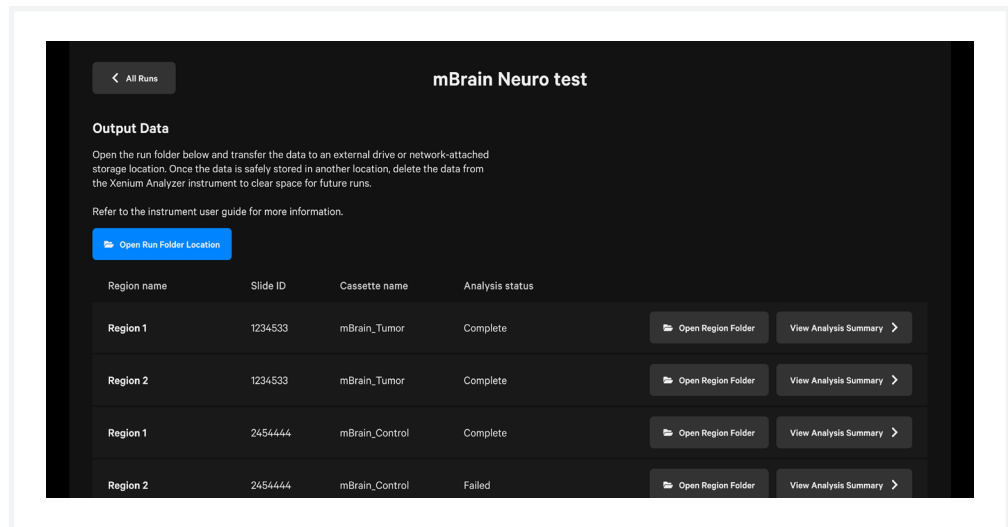

Click “Open Run Folder Location” to access the top-level output folder on the desktop. Click the individual runs to open a run-specific screen. To access the region-specific output folder, click “Open Region Folder”. A summary of the analysis is available in “View Analysis Summary” folder.

Data Output

contd.

All run data is stored in the output directory on the Xenium Analysis Computer and can be accessed through the output folder of the desktop.

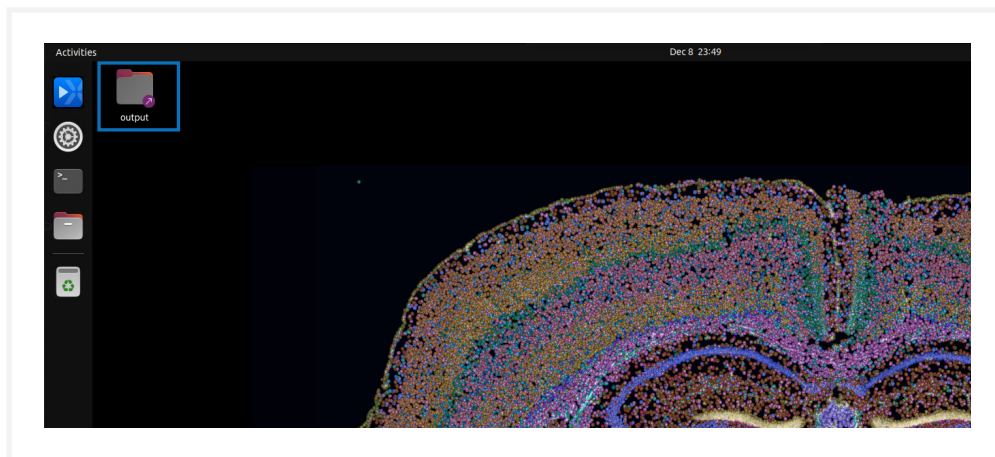

For more information about the output files within each subfolder, refer to the 10x Genomics Support website.

Data Storage Capacity

The Xenium Analysis Computer has a storage capacity of 8 TB NVMe. This capacity is adequate for storing data acquired from more than 50 Xenium Analyzer runs, assuming that the data is acquired across the full imaging area of two Xenium slides for hundreds of RNA targets.

Data Export

Exporting the output data after each instrument run is highly recommended to reduce the system load and to avoid any possibility of losing run data. User will be responsible for managing and deleting output bundles from the runs.



Export data only after the run is complete and not while the run is in progress. DO NOT interact with the instrument during the run; avoid touching the keyboard and the trackpad.

Data Output

contd.

Multiple options are available to export run data from the instrument.

Local Area Network (LAN) (Recommended Option)

- Users can also work with their institution's IT department to set up Local Area Network (LAN) for data transfers. Xenium Analyzer can be configured to work with non-persistent networks such as Network File Share (NFS) or Common Internet File System (CIFS).
- The Xenium Analyzer can mount NFS and CIFS shared drives. The following commands will create a new folder in the `xeniumuser` home directory and mount the shared drive to that folder:

```
mkdir /home/xeniumuser/shared_drive
sudo mount {path_to_shared_drive} /home/xeniumuser/shared_drive
```

- Mounted drives will be lost if the Xenium Analyzer is rebooted. To automatically mount shared drives after a reboot, an entry can be added to `/etc/fstab`. The `xeniumuser` account can use a command such as `sudo vim /etc/fstab` to edit that file.
- For Xenium Analyzer software v 1.8+, a `xeniumuser` write-only file is provided to store network share credentials in `/opt/.smbcreds`.
- The following names are already mounted on the Xenium Analysis Computer. Avoid mounting another volume with these names:

```
/data
/output
/scratch
/conf
/home
/opt
```

Data Output *contd.*

Portable USB drive (Alternative Option)

- Attach a portable USB drive to the USB port on the Xenium Analysis Computer to export the output files.
- USB drive must have ≥ 256 GB storage capacity, version 3.0 or higher, and be pre-formatted to the exFAT file system, which is compatible with the operating systems indicated below.

 Label cannot contain spaces or the following characters !@#%&*+= Failure to comply will cause user to be unable to write to the drive.

File System	Windows (7/8/10)	macOS (10.6.5 & later)	Ubuntu Linux
exFAT	Yes	Yes	Yes

- Once copy shows complete, user should eject USB properly (do not pulling from system until eject is successful). If eject operation fails indicating the device is busy, wait until that is resolved and eject is successful before removing USB.
- Persistent network mounts can also be configured during instrument installation or later. For more information, contact support@10xgenomics.com.

Ejecting USB Drive

 USB drive must be properly ejected prior to removing from computer. Failure to properly eject USB can result in files being lost or damaged.

This is the preferred method of ejecting the USB instead of selecting the eject icon next to the device name.

- Open Files in the Ubuntu OS and locate the USB device in the sidebar.
- Right-click the name of the USB and select Safely Remove Device.

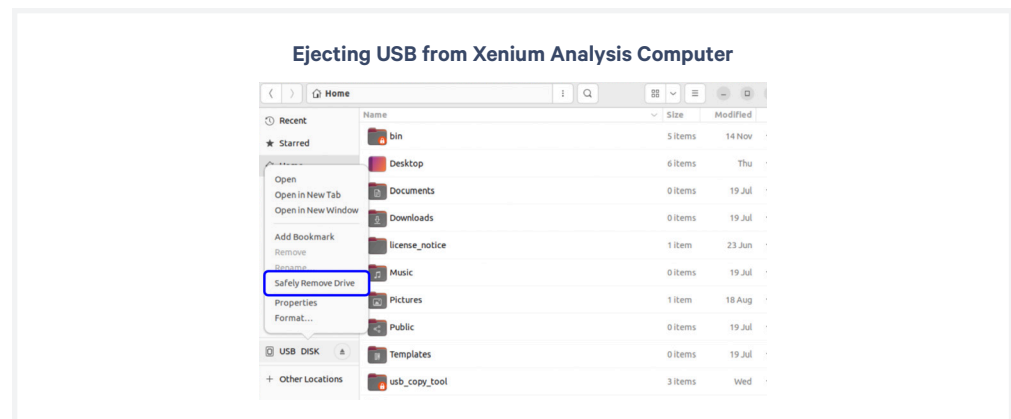



Maintenance

Maintenance

Cleanup After Run

After run completion, a button will appear on the instrument touchscreen to initiate cleaning of the instrument fluidic system. The screen will display progress and the estimated time remaining. This process will take **~5 min.**



Follow local lab safety or EHS requirements for using compressed air.

Interior

Wipe the instrument deck with 70% ethanol or 70% isopropanol, including the fluidic line inlets and outlets (reagent buffer bottle inlets, waste bottle outlet, extraction tip inlet). Use compressed air to dry and remove debris as needed.

DO NOT use 5-10% bleach for routine cleaning. In very rare instances that require decontamination as per an institution's protocol (for example moving from a BSL2 facility), 5-10% bleach solution may be used for wiping the deck. Frequency of such cleaning should not exceed 1-2 times during the life of the instrument.



Do not use acetone or other harsh solvents unless otherwise advised. Apply all standard safety practices when using cleaners, and dispose of any generated waste in a responsible manner.

Exterior

The exterior of the Xenium Analyzer should always be kept clean and free of dust and debris that may affect its function and/or cooling efficiency. Generally, the exterior finish can be wiped down using a mixture of mild detergent and distilled water applied to a slightly damp lab towel.

Cassette Carrier (Inside)

Always clean carriers prior to loading a run. If liquid has leaked during a run, clean carriers after a run when unloading.

- a. Spray 70% isopropanol onto a lint-free laboratory wipe and clean the surface of the carrier, paying attention to the raised areas that come into contact with the slide. Let evaporate.
 - i. Optional: Spray 70% isopropanol on a cotton swab and use to clean off crevices if necessary.
- b. Use compressed air to remove any remaining lint paying close attention to raised areas. Confirm surface is dry.



Follow local lab safety or EHS requirements for using compressed air.



A dry, clean, lint-free surface on both the slide bottom and instrument cassette carrier is critical for a proper instrument run. Any debris or lint can interfere with image acquisition.

Maintenance

contd.

Cassette Carrier (Lid)

In some cases, if imaging buffer comes into contact with the lid of the cassette carrier, a stain can occur and will be visible after the run has completed. This stain is cosmetic and has no impact on instrument performance. However, cleaning following a run is advised as older stains are typically more difficult to remove.



For relatively new stains (< 1 week), gently wipe the stain with 100% acetone with a lint-free wipe.

For older stains that cannot be removed using acetone (> 1 week), gently wipe the stain with 1M NaOH with a lint-free wipe. If necessary, a soft bristle brush may be used to aid in removal.



Refer to SDSs for handling guidance and safety practices (such as PPE). Dispose of any waste following regional and institutional guidelines.



Only use the solvents recommended above at the specified concentration or molarity. DO NOT use alternative solvents to remove stain as they can damage the coating on the cassette carrier. DO NOT use solvents to clean any other surfaces on the instrument.

Maintenance

contd.

Powering OFF instrument

While instrument shutdown is not required, user may power off instrument if it is expected to be idle for long periods of time.

To power off the instrument, press and hold the power button on the right side of the instrument for **>3 sec.**



Do NOT turn off the Breaker Switch or Main Power Switch. Both must remain in the ON position for proper instrument function.

Do NOT use the Touchscreen to shutdown the instrument.

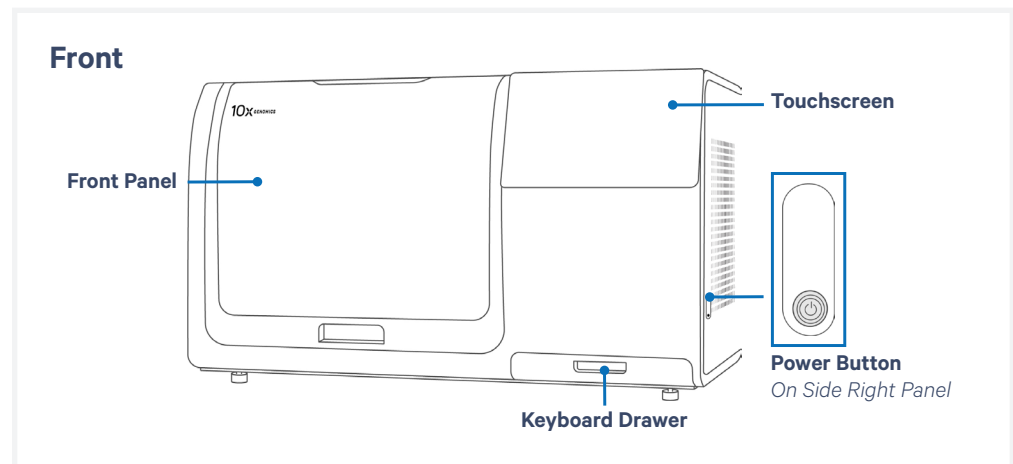

Service

For routine preventative maintenance, 10x Genomics will contact the user at regular intervals to schedule and perform routine service and maintenance.



Electrical shock hazard. DO NOT open the Xenium Analyzer in a manner not specified during standard operation. There are no user-serviceable parts inside. Refer all servicing to qualified 10x Genomics service personnel.

Servicing is required when the Xenium Analyzer has been damaged in any way (e.g., a power entry module or plug is damaged, liquid was spilled into, or objects fell into the instrument, the instrument does not operate properly, or has been dropped). For more information, contact support@10xgenomics.com.

Only the power cords supplied with the Xenium Analyzer will be used during installation. DO NOT replace cords with a non-approved power cord as it may be inadequately rated to handle the electrical loads.

Maintenance

contd.

Environmental Requirements

It is the design intent of the Xenium Analyzer that it be used in a typical indoor laboratory environment. The instrument's operating temperature is 19–25°C (66–77°F), humidity 80% Max (Non-Condensing).

See [Instrument Specifications](#).

Troubleshooting



92 Troubleshooting

100 Errors

Troubleshooting

Check Assembled Cassette for Leaks

Prior to loading the assembled cassette, check that no liquid is leaking from the assembly. Dry the front and the back of the slide completely using a lint-free laboratory wipe while avoiding touching or damaging the tissue sections. Inspect the slide carefully to ensure it is seated fully within the cassette before assembly.

Scenarios that may indicate improper Xenium Cassette assembly include:

- Cassette does not click shut or appears domed/has a gap after assembly (see image below).

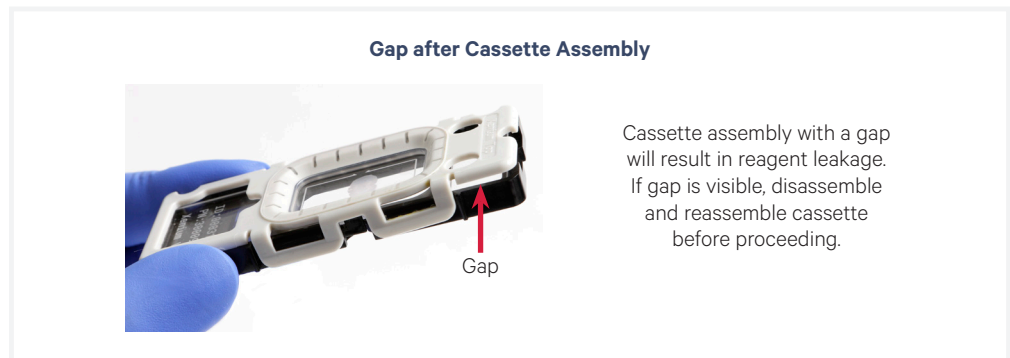

- For Xenium Cassette v2, slide is not placed underneath slide clip.
- Assembly is placed on a dry surface, the surface is wet following removal of the assembly, indicating reagent leakage from the cassette.

If cassette assembly is leaking prior to instrument run, disassemble and reassemble the cassette as instructed below. Add **1,000 µl** PBS-T to cover the slide before loading onto the instrument. **Confirm cassette is no longer leaking before loading.** Leaks may cause instrument damage.



Ensure the slide sections do not dry out during the process.

Troubleshooting *contd.*



Exercise caution when handling slide edges to prevent injury.

Xenium Cassettes (for Xenium v1 Workflows)

Disassemble Xenium Cassette

- 1 Pull inner clips from inner tabs to detach top and bottom halves of cassette

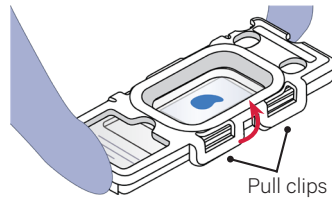

- 2 Open cassette by continuing to lift inner clips upward

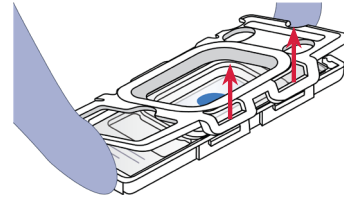

- 3 Hold slide by the label and lift slide out from bottom half

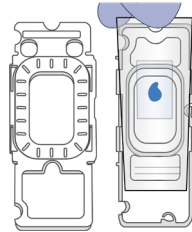

Avoid touching tissue region

Reassemble Xenium Cassette

- 1 Place top and bottom halves of cassette on bench with the top cassette facing down and bottom cassette facing up.

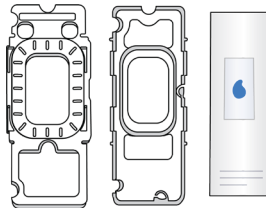

- 2 Place Xenium slide with tissue side facing upwards into bottom half of cassette; ensure label is toward bottom of cassette.



Avoid touching tissue region

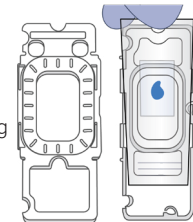

Slide facing up

- 3 Press slide down into grooves of the bottom half of the cassette until it sits firmly in place.

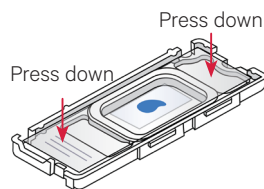

- 4 Secure clips of top half with tabs of bottom half (on both sides).

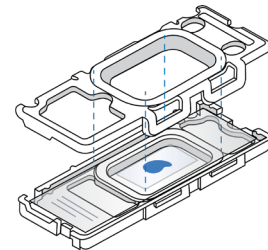

- 5 Apply even pressure on top of cassette until all clips click shut. Verify that clips are completely secured over tabs.

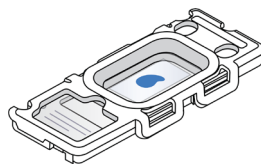

- 6 Add 100 μ l PBS-T to cover the slide before loading onto the instrument

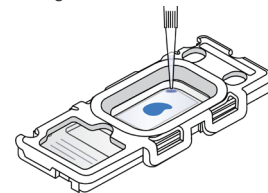

Troubleshooting *contd.*



Exercise caution when handling slide edges to prevent injury.

Xenium Cassettes v2 (for Xenium Prime Workflow)

Disassemble Xenium Cassette v2

- 1 Pull inner clips from inner tabs to detach top and bottom halves of cassette.

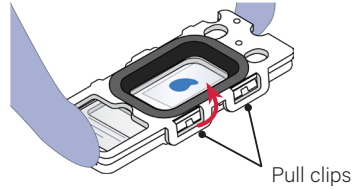

- 2 Open cassette by continuing to lift inner clips of top cassette upward.

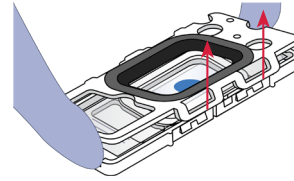

- 3 Hold top of slide and slowly lift slide out from underneath the slide clip. Then slowly remove from bottom cassette

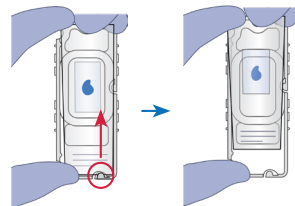

Move slide from underneath clip

Reassemble Xenium Cassette v2

- 1 Place top and bottom halves of cassette on bench with the top cassette facing down and bottom cassette facing up.

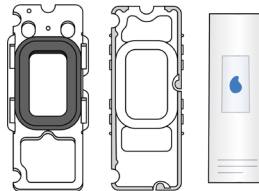

- 2 Place Xenium slide with label at bottom and tissue facing up into bottom half of cassette. Slip slide under slide clip located at bottom right of cassette.

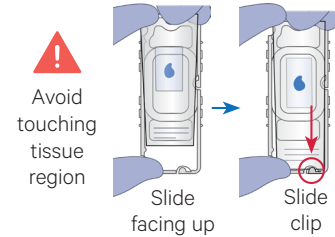

- 3 After slide is safely underneath slide clip, place opposite side down into carrier. Ensure slide is sitting flat.

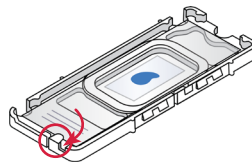

- 4 Align inner clips of top cassette to inner tabs of bottom cassette. Bring opposite side down until 2 audible clicks are heard.

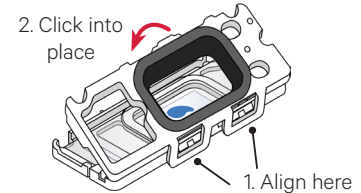

- 5 Verify that clips are completely secured over tabs. Top cassette should sit flat and no gaps should be visible around entire cassette.*

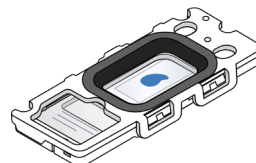

- 6 Add 100 µl PBS-T to cover the slide before loading onto the instrument

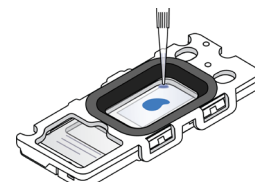

Troubleshooting contd.

Storing slides after instrument failure

In the event of instrument run failure, slides may be stored for a future run. Fully assembled cassettes (with lid) can be stored short term (up to 1 week) or long term (up to 2 months). It is critical that cassettes should always be stored hydrated with recommended reagent and stored at the recommended temperature to maintain sample integrity.

Short-term Storage (\leq 1 week), Xenium v1 and Xenium Prime assays:

- a. Store in 1,000 μ l PBS-T at 4°C in the dark. Ensure that the slide is stored in microbe-free and nuclease-free conditions, with a Xenium Cassette Lid v2 applied to prevent evaporation.

Long-term Storage (1 week – 4 months), Xenium v1 assays only:

- a. Remove all PBS-T from the cassette well.
- b. Add **1,000 μ l 70%** ethanol, incubate for **2 min** at **room temperature**, remove the ethanol.
- c. Add **1,000 μ l 100%** ethanol, incubate for **2 min** at **room temperature**, remove the ethanol.
- d. Add **1,000 μ l 100%** ethanol, incubate for **2 min** at **room temperature**, remove the ethanol.
- e. Remove slide from the cassette and place in a slide mailer containing 10 ml cryoprotectant or more to fully submerge the slide (30% Glycerol prepared in PBS is recommended).
- f. Clean the cassette. Discard lid.
 - i. Rinse under running Milli-Q water
 - ii. Spray with 70% isopropanol
 - iii. Repeat Milli-Q water and 70% isopropanol wash
 - iv. Rinse under running Milli-Q water
 - v. Air dry and save for a subsequent instrument run.
- f. Store at -20°C for up to 4 months.
- g. When ready to use:
 - i. Equilibrate the mailer with the slide to room temperature
 - ii. Once completely thawed, rinse the mailer 3X with **10 ml** PBS-T
 - iii. Remove the slide from the mailer and assemble in the cassette
 - iv. Add **1,000 μ l** PBS-T to the cassette well.

Contact support@10xgenomics.com if more information is needed.

Troubleshooting
contd.

Full Instrument Shutdown

In some instances, it may be necessary to perform a full power-cycle of the instrument when instructed by 10x Genomics personnel.

Please contact support@10xgenomics.com prior to attempting the following steps.

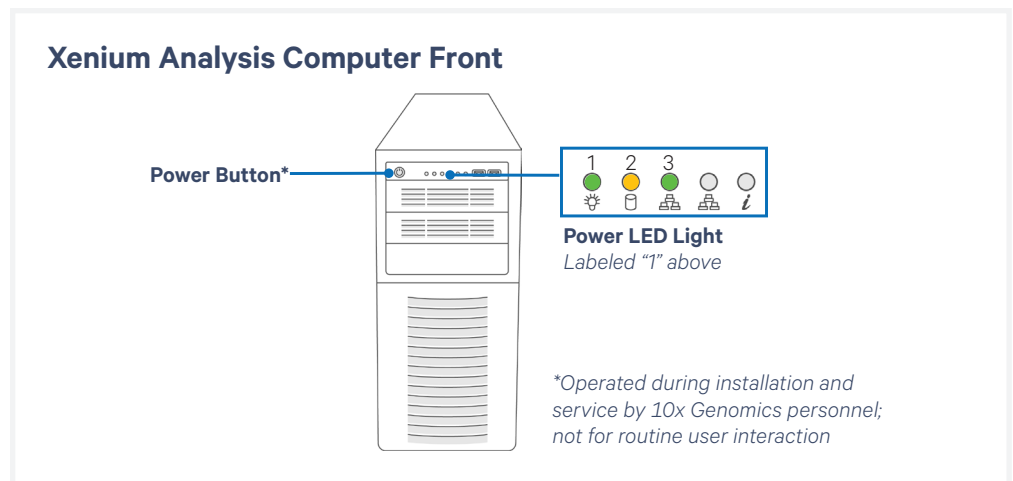
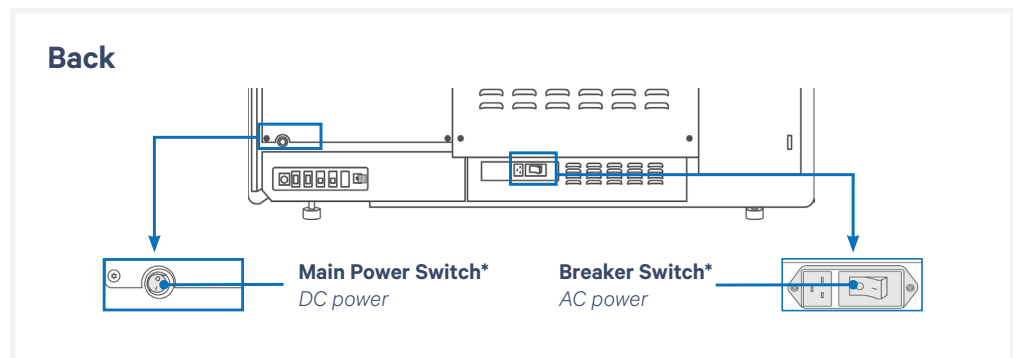
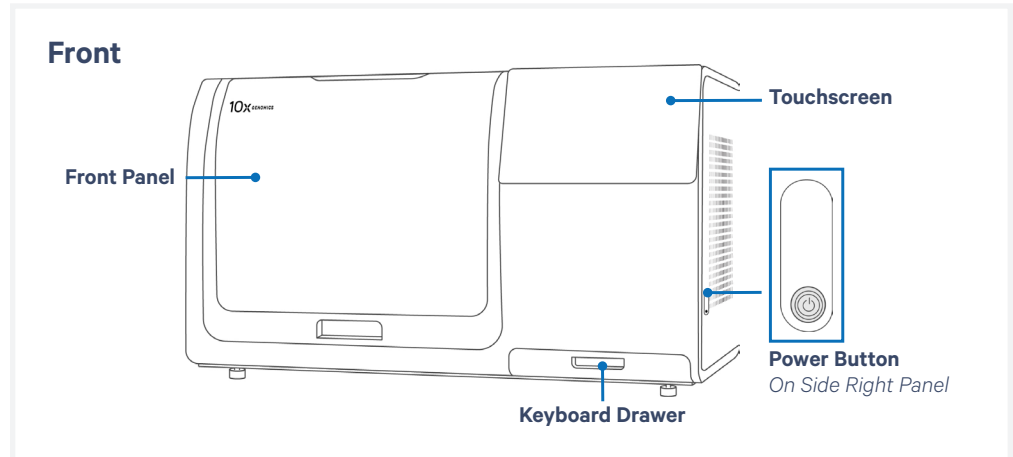

Troubleshooting

contd.

- a. Press and hold the side power button down for 3 seconds. The touchscreen monitor should turn black.
- b. Wait at least 3 minutes for the internal computer and Xenium Analysis Computer to power down.



Ensure that the Power LED on the Xenium Analysis Computer is OFF before proceeding to the next step.

If the Xenium Analysis Computer does not shut down after >10 minutes, manually shut down it by holding down the red Power Button for 3 seconds.

- c. Toggle the black Main Power Switch to the OFF position.
- d. Toggle the white Breaker Switch to the OFF position. Wait 3 minutes.
- e. To power the system back ON, toggle the white Breaker Switch to the ON position.
- f. Toggle the black Main Power Switch to the ON position
- g. Turn on the Xenium Analysis Computer by pressing the red Power Button for 3 seconds or until the Power LED illuminates.

Troubleshooting *contd.*

Errors while Loading and Unloading Consumables

Listed below are errors (along with solutions) that may occur when loading and unloading consumables on the instrument and during data analysis.

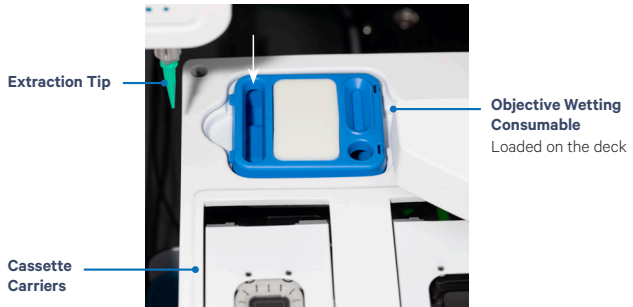
Error	Solution
During loading and unloading consumables	
Objective Wetting Consumable not present or not full	Place a new, unused objective wetting consumable in the correct location on the instrument deck (behind the cassette carrier; the reagent priming reservoir should be on the left (white arrow)).
	
Instrument front panel is not closed and/or locked	Apply even pressure to push front panel in. No gap should be visible from side angle.
Check bottle carrier	Ensure that the bottle carrier with reagent bottles and Waste Bottle is pushed all the way into position inside the instrument.
Missing Waste Tip Tray	Slide out the waste tip drawer and place the empty Waste Tip Tray inside the drawer. Close the drawer and proceed.
Empty Waste Tip Tray	Slide out the waste tip drawer and remove the tip tray. Discard used pipette tips and place the empty tip tray inside the drawer. Close the drawer and proceed.
Left or right cassette is missing	Load an assembled cassette in the correct position on the cassette carrier.
Cassette Carrier lid not properly closed	Ensure that both cassette carrier lids click into place to be properly closed.
Missing Waste Bottle	Place the Waste Bottle in the bottle carrier. Push the bottle carrier caps down to the top of the Waste Bottle.
Empty the Waste Bottle	Remove the Waste Bottle from the carrier and discard the waste. Follow institutional or local guidelines for proper waste disposal. Return the bottle to the bottle carrier. Slide the bottle carrier back and proceed to the next step.

Troubleshooting *contd.*

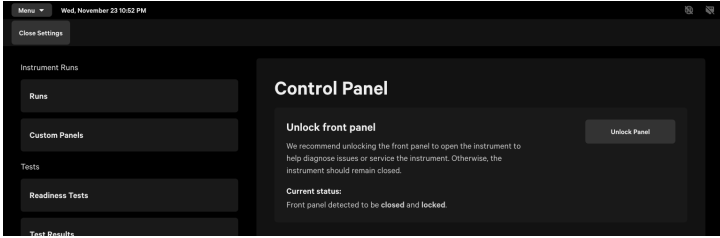
Error	Solution
During loading and unloading consumables	
Need to open the front panel to access the instrument deck prior to starting a run	Unlock the front panel from Menu Settings, accessible on the top bar of the screen.
	 <p>The screenshot shows the 'Control Panel' interface. It features a 'Close Settings' button at the top left. Below it, there are sections for 'Instrument Runs', 'Runs', 'Custom Panels', 'Tests', 'Readiness Tests', and 'Test Results'. The main area is titled 'Control Panel' and contains the following text: 'Unlock front panel', 'We recommend unlocking the front panel to open the instrument to help diagnose issues or service the instrument. Otherwise, the instrument should remain closed.', and 'Current status: Front panel detected to be closed and locked.' There is an 'Unlock Panel' button on the right side.</p>
During data analysis	
Insufficient storage available	There is insufficient storage to save analysis output data. Delete data from previous runs from the output directory. Contact support@10xgenomics.com for assistance.
During data analysis <i>may be recoverable with assistance from 10x Support team</i>	
Analysis failed to start	A problem prevents starting the analysis. The run has been terminated. Samples will be kept hydrated until run cleanup. Refer to the Unloading Consumables section for guidance regarding keeping samples stable after unloading. Contact support@10xgenomics.com for assistance.
Analysis failed	A problem has occurred during analysis. The run has been terminated. Samples will be kept hydrated until run cleanup. Refer to the Unloading Consumables section for guidance regarding keeping samples stable after unloading. Contact support@10xgenomics.com for assistance.
Region analysis failed to finalize	An error occurred during analysis for a specific region “{{Region}}”. Analysis will continue for the other regions. After the run is complete, contact support@10xgenomics.com for assistance.
Failed to generate output data files	Analysis output run data for the region “{{Region}}” could not be saved. Saving output for the other regions will continue. After the run is complete, contact support@10xgenomics.com for assistance.
Cannot save output data	There was a problem in saving analysis output data. Contact support@10xgenomics.com for assistance.
Other	
Screen/instrument frozen	Contact support@10xgenomics.com for assistance before proceeding.

Errors

Listed below are the types of errors that may be encountered when operating the Xenium Analyzer. The instrument touchscreen will guide the user through recoverable errors. If the error continues, or if the instrument has seen critical errors, contact support@10xgenomics.com with the error code displayed on the screen.

Contextual Error Messages

While completing information fields in the instrument screen, invalid input may be detected. The field where input correction is needed will be highlighted in a red bounding box and guidance on resolving the error will appear adjacent to the input field.

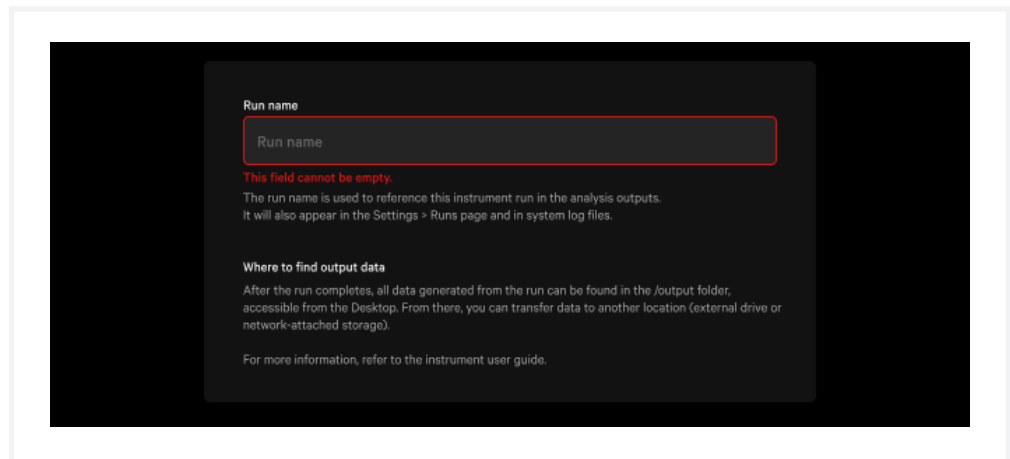

Error Alerts

When an error occurs outside of completing information fields, an error alert will appear on the screen. Follow the instructions displayed on the screen.

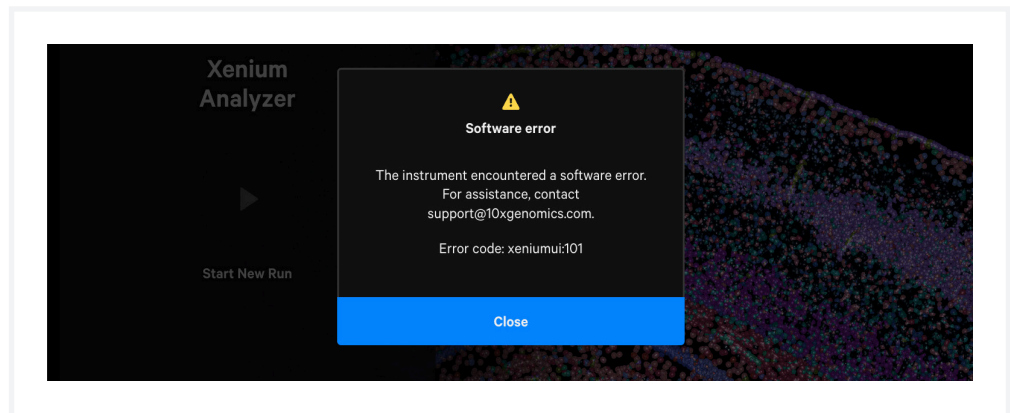

Errors

contd.

System Retry

Some errors may provide the option to retry the previous system operation. It is recommended to email support@10xgenomics.com for assistance before attempting retries.

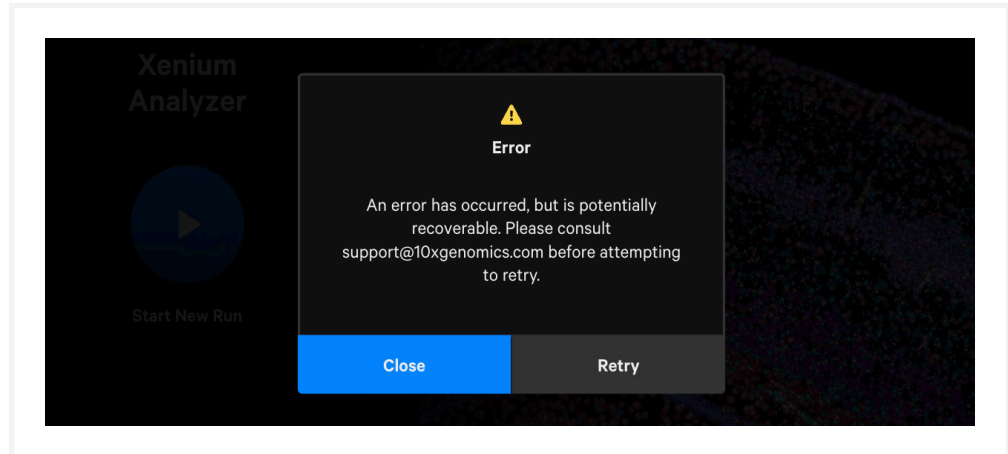

Home Screen Error Indicator

Some errors may prevent the user from starting a new run. An error button will appear in the upper right corner of the home screen. Click the button to open the error alert and follow the instructions displayed on the screen.

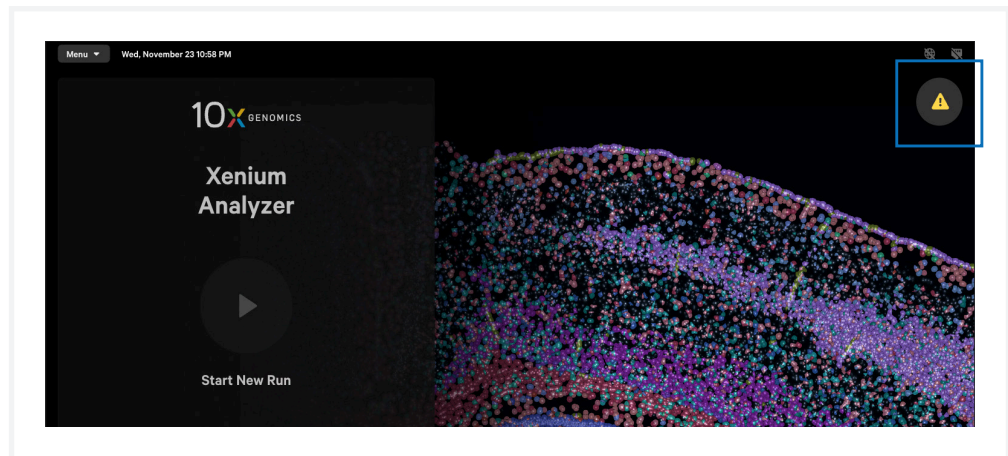

Critical Errors

Contact support@10xgenomics.com with the error code. Do not proceed with any further runs.

Errors

contd.

Enable Remote Support for Troubleshooting Guidance

When contacting 10x Genomics for technical support, 10x Genomics personnel may remotely access the instrument for providing troubleshooting guidance. Enable remote support by clicking “Menu > Remote Support”, and then moving the toggle to ON. Once enabled, the header bar on the instrument screen will display “10x Genomics Remote Support On.”

Authorized 10x Genomics personnel will remotely access Xenium Analyzer instruments when given explicit permission from the user to do so. Only data necessary to provide troubleshooting support will be recovered and handled.

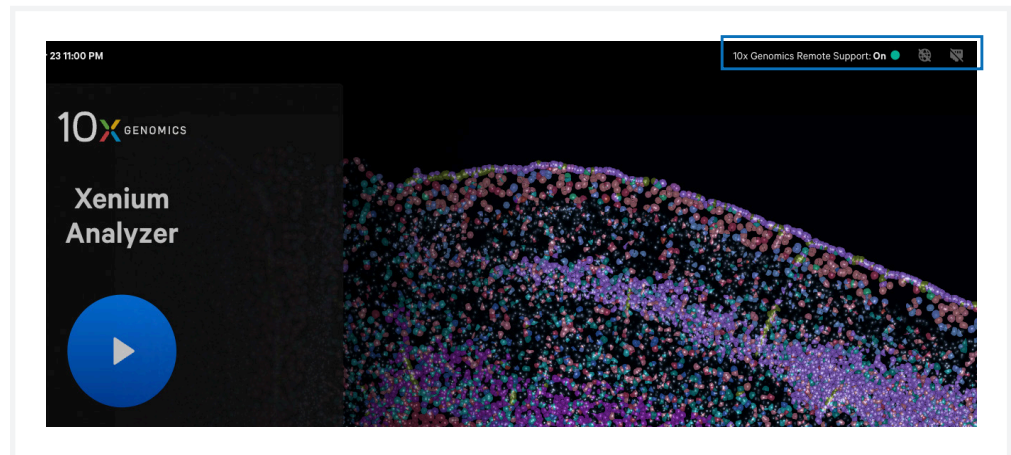
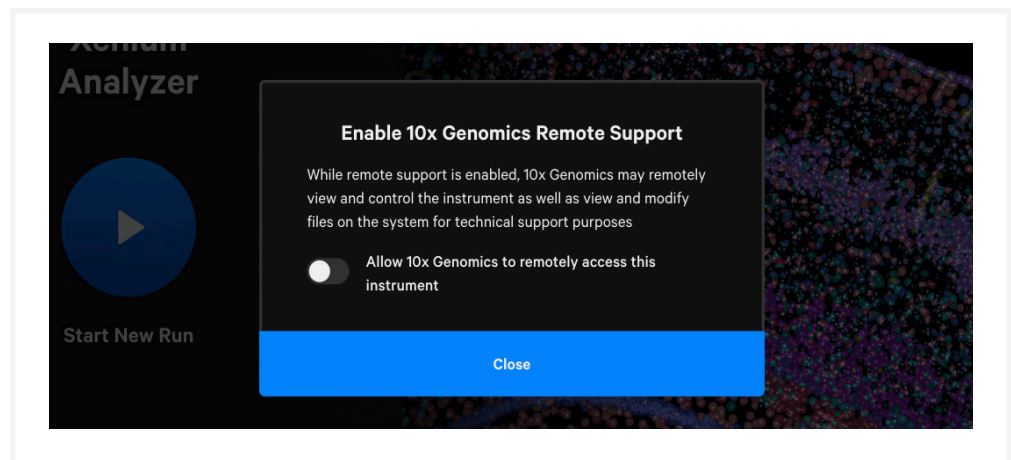

Errors

contd.

Remote access may also be enabled while a run is not in progress from the Connectivity Settings, found by navigating to “Menu > Connectivity”.

