

Visium HD FFPE Tissue Preparation Handbook

Introduction

The Visium HD Spatial Gene Expression workflow is designed to analyze mRNA in tissue sections derived from formalin fixed & paraffin embedded (FFPE) tissue samples. This workflow is facilitated via the CytAssist instrument, which enables the capture of ligated probe products onto the Visium HD Slide. A single CytAssist run accommodates up to two stained tissue slides (tissue placed on a blank slide) as sample input. Proper tissue handling and preparation techniques preserve the morphological quality of the tissue sections and the integrity of mRNA transcripts. Maintaining tissue adhesion and high-quality RNA is critical to assay performance.

This FFPE Tissue Handbook provides guidance on:

- Removing hardset coverslips from archived tissue slides
- Performing RNA quality assessment of FFPE tissue blocks or archived Hematoxylin & Eosin (H&E)-stained tissue sections on tissue slides
- Sectioning of tissue blocks and placement of sections on blank slides
- H&E Staining and imaging
- Immunofluorescence (IF) Staining and imaging

Additional Guidance

This protocol is compatible with most human and mouse tissue types. Modifications to the sample preparation protocol such as section flotation time and water bath temperature may be required for the preparation of certain tissue blocks such as breast, colon, skin, and lung. Additional recommendations are also provided to minimize the risk of tissue detachment when working with tissue blocks that have large amounts of connective tissue such as breast or colon. Refer to the 10x Genomics Support website for additional resources, including a list of tissues tested.

Contents

Visium HD Spatial Gene Expression Reagent Kits

Visium HD Spatial Gene Expression Reagent Kits	4
10x Genomics Accessories	6
Third-Party Items	7

Tips & Best Practices

Reagent Addition to & Removal from Wells	15
Visium Slide Seal Application & Removal	17

Handbook Overview and Navigation

Overview	19
----------	----

1. Archived Slide Processing

1.0 Preparation	23
1.1 Hardset Coverslip Removal	25
1.2 RNA Extraction	28
1.3 Destaining	30
1.4 Decrosslinking	32

2. FFPE Tissue Sectioning & Section Placement

2.0 Exposing the Tissue or Facing the Block	35
2.1 RNA Quality Assessment of FFPE Tissue Block	36
2.2 Sectioning	37
2.3 Section Placement	39

3. Deparaffinization, H&E Staining, & Decrosslinking

3.0 Preparation	43
3.1 Deparaffinization	48
3.2 H&E Staining	50
3.3 Coverslip Mounting	51
3.4 Imaging	52
3.5 Coverslip Removal	52
3.6 Destaining	53
3.7 Decrosslinking	55

4. Deparaffinization, Decrosslinking, & IF Staining

4.0 Preparation - Buffers	61
---------------------------	----

4.1 Deparaffinization	69
4.2 Decrosslinking	71
4.3 Immunofluorescence Staining	73
4.4 Immunofluorescence Staining - Fluorophore Conjugated Primary Antibodies	73
4.5 Immunofluorescence Staining - Primary & Secondary Antibodies	75
4.6 Coverslip Mounting	79
4.7 Imaging	79
4.8 Coverslip Removal	80

Troubleshooting

Appendix

Visium HD Spatial Gene Expression Reagent Kits

Consult SDS for handling and disposal information

Visium HD Spatial Gene Expression Reagent Kits

Visium HD Reagent Kit – Small, PN-1000668

Visium HD Reagent Kit – Small			
PN-1000668			
(store at -20°C)			
		#	PN
○	Amp Mix B	1	2000567
●	Extension Enzyme	1	2000389
●	Extension Buffer	1	2000409
●	RNase Enzyme	1	3000605
●	2X RNase Buffer	1	2000411
●	Perm Enzyme B	1	3000553
●	TS Primer Mix B	1	2000537
●	Decrosslinking Buffer B	1	2001094



Visium HD Cassettes, 6.5 mm, 4 rxns PN-1000669

Visium HD Cassettes, 6.5 mm 4 rxns PN-1000669 (store at ambient temperature)		
	#	PN
Visium 2-port Cassette S3, 6.5 mm		
Visium Cassette 2-port gasket, 6.5 mm	2	3001831
Visium Cassette Bottom	2	3001830
Visium Tissue Slide Cassette S3, 6.5 mm		
Tissue Slide Cassette Top	4	3001826
Movable Tissue Gasket 6.5 mm (preassembled with translator)	4	3001828
Movable Tissue Gasket Translator (preassembled with gasket)	4	3001927
Tissue Slide Cassette Bottom	4	3001825
Visium Slide Seals, 12 pack	2	2000283



*The Visium HD Workflow is run with Visium Tissue Slide Cassettes S3 and Visium Cassettes S3. These are referred to as Tissue Slide Cassettes and Visium Cassettes in this document, respectively. Consult the Visium S3 Tissue Slide Cassette Assembly Quick Reference Card (CG000730) for assembly and disassembly information.

Visium 8-port Cassette S3, 4 pk PN-1000685

Visium 8-port Cassette S3 4 pk PN-1000685 (store at ambient temperature)		
	#	PN
8-port Gasket Top	4	3001827
Tissue Slide Cassette Bottom	4	3001825



Visium Tissue Slide Cassette S3, 6.5 mm, 4 pk PN-1000684

Visium Tissue Slide Cassette S3, 6.5 mm 4 pk PN-1000684 (store at ambient temperature)		
	#	PN
Tissue Slide Cassette Top	4	3001826
Movable Tissue Gasket 6.5 mm	4	3001828
Movable Tissue Gasket Translator	4	3001927
Tissue Slide Cassette Bottom	4	3001825



10x Genomics Accessories

Product	#	Kit and Part Number	Part Number (Item)
10x Magnetic Separator	1	Visium CytAssist Reagent Accessory Kit 1000499	1000394 or 120250
Low Profile Thermocycler Adapter	2		3000823

Third-Party Items

Successful execution of the Visium HD workflow requires third-party reagents, kits, and equipment in addition to those provided by 10x Genomics. All third-party reagents and consumables should be obtained prior to starting this workflow.

Consult the Visium HD Spatial Applications Protocol Planner (CG000698) for a list of the following third-party items:

- Additional reagents, kits, and equipment
- Tested pipette tips
- Tested thermal cyclers
- Tested blank slides



10x Genomics has tested all items listed in the Protocol Planner. Unless otherwise noted, 10x Genomics recommends using these items to ensure optimal assay performance. Substituting materials may adversely affect assay performance.

Tips & Best Practices

Icons



Tips & Best Practices section includes additional guidance



Signifies critical step requiring accurate execution



Troubleshooting section includes additional guidance



Indicates a version specific update in volume, temperature, instruction, etc.

Sample Preparation

- Store FFPE tissue blocks at 4°C and avoid exposure to direct light to ensure even chilling and preservation of RNA integrity.

RNA Quality Assessment

- Before section placement on slides, assess RNA quality of the tissue block or archived sections before proceeding with sectioning by calculating the percentage of total RNA fragments >200 nucleotides (DV200) of RNA extracted from tissue sections.
- Various factors could lead to variations in DV200 scores, such as:
 - Specific tissue types
 - Diseased or necrotic tissues
 - Sample preparation and handling
 - Loading concentration or ladder errors on the RNA QC platform

Section Thickness

- Recommended section thickness is 3–10 μm . Though the entire recommended range of thicknesses was tested internally, most sections were cut at 5 μm , the thickness referenced throughout this protocol.

Water Bath Temperature & Section Floating Time

- Optimal water bath temperature and section floating time are critical for tissue section expansion. 42°C is the recommended water bath

temperature for most tissues. However, water bath temperature may need optimization based on the tissue type.

- If the tissue is taking too long to expand, turn the water bath temperature up by 1 or 2 degrees and let the section float for longer.
- If the tissue is expanding too quickly and dissociating, turn the water bath temperature down by 1 or 2 degrees and shorten the floating time.
- Clean water bath according to manufacturer recommendations, followed by an RNase decontamination solution.

Section Placement on Blank Slides

- After section placement, blank slides are referred to as tissue slides.
- Prior to section placement, draw an outline of the allowable area on the back of the blank slide to ensure downstream compatibility with the Visium CytAssist instrument and Tissue Slide Cassette (Consult the Visium CytAssist Accessory Kit Quick Reference Card CG000548 on the 10x Genomics support website for more information).
- If placing multiple sections on a blank slide, ensure that the paraffin and/or tissue do not overlap.
- Each tissue slide can only be processed with the Visium CytAssist instrument once.

Practice Section Placement

- Practice correct section placement using nonexperimental blocks.

Section Attachment

- Tissue block and section quality can affect the section attachment to blank slides.
- Choice of blank slide may influence section attachment. Review the Tested Tissues List for recommendations on slides for specific tissues.
- 10x Genomics recommends placing tissues with large amounts of connective tissue (like breast, skin, or colon) or composed of multiple cores (TMAs) on Schott Nexterion Slide H - 3D Hydrogel Coated Slides (Schott North America, PN-1800434) to minimize risk of tissue detachment. Schott H slides may also be used if prior detachment has been observed with tissues of interest.

- Follow manufacturer instructions for Schott Nexterion Slide H slides, which have specific requirements for storage and equilibration.
- Tissue detachment may occur due to factors such as the quality of paraffin used during the tissue embedding process, the age of the tissue block, tissue section thickness, and the length of time used to infiltrate a tissue in paraffin.
- Carefully inspect the tissue block to gauge the extent of dehydration. Allow sufficient time in the ice bath to ensure proper hydration.
- Use a new, clean blade for sectioning each tissue type. Inspect the blade after every 20-25 sections and adjust to the blade areas that are not nicked or rough. Replace the blade after ~50 sections.
- Perform sectioning in a continuous motion to get a ribbon of sections. Sections should be separated while floating in the water bath. If floating multiple sections, monitor float time carefully.
- Ensure collected sections have the same thickness throughout experiments and replicates.
- Allow the section to float in the water bath until it is free of folds and wrinkles. Folds are associated with poor probe capture and can be identified via H&E staining, or by eye or under the microscope prior to staining. See [Troubleshooting on page 81](#) for more information.
- After section placement, gently flick the slide to remove excess water. A fan may be used to assist in drying. Leftover moisture under the tissue may result in tissue detachment.

Optional - Area of Interest Annotation

If a tissue section does not fit completely within the Visium HD Slide Capture Area, a smaller area of interest (AOI) should be defined.

The AOI should be:

- Small enough to fit inside a well in a Tissue Slide Cassette gasket. Tissue outside of the gasket will not be processed during the assay workflow.
- Centered within the appropriate Capture Area size on the Tissue Slide Stage on the Visium CytAssist instrument.

Defining an AOI can occur after section placement by examining the tissue under a microscope or after H&E staining and imaging.

H&E Staining:

- Annotate the AOI using a marker on the back side of the tissue slide based on the assessment of tissue morphology from the H&E image. This annotation can serve as a reference for gasket placement when assembling the tissue slide in the Tissue Slide Cassette.
- Prior to loading the tissue slide onto the CytAssist instrument, remove annotations with isopropanol or ethanol. Failure to remove annotations on the back of the tissue slide can lead to improper tissue detection, causing automatic tissue registration to fail. Should this occur, manual tissue registration on Loupe Browser will be required.
- When loading the tissue slide on the instrument, the pale eosin staining of the tissue area included within the gasket and the darker H&E staining of tissue areas outside the cassette will provide sufficient contrast to identify and align the correct tissue region on the CytAssist.

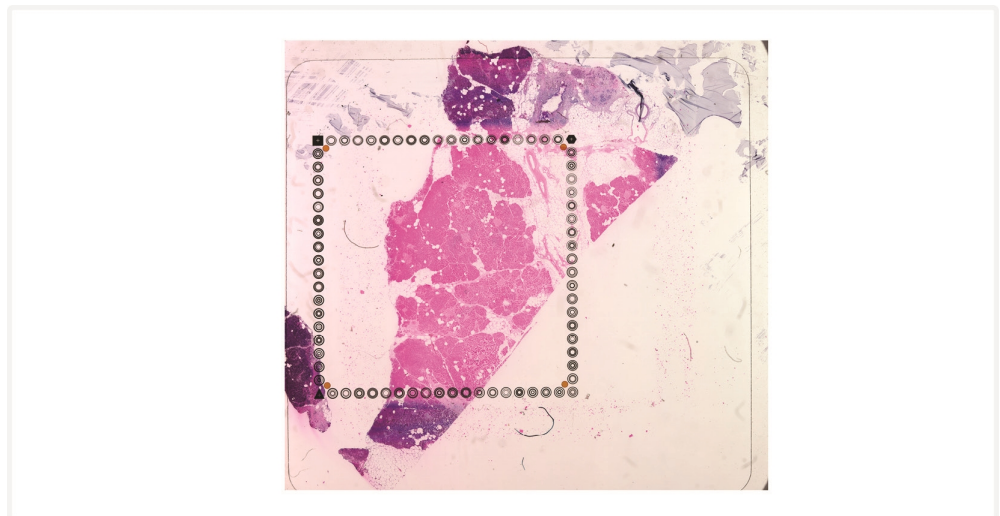

IF Staining:

- Prior to immunostaining, the tissue slide must be assembled in the Tissue Slide Cassette for decrosslinking. Since decrosslinking requires placing the gasket over the AOI prior to staining, 10x Genomics recommends using tissue morphology information from an adjacent H&E or IF stained section to annotate the back of the tissue slide. This annotation can serve as a reference for the gasket placement when assembling the tissue slide in the Tissue Slide Cassette for the decrosslinking and immunostaining steps as well as help with reapplying the gasket after coverslip removal.
- Prior to loading the tissue slide onto the CytAssist instrument, remove annotations with isopropanol or ethanol. Failure to remove the annotations on the back of the tissue slide can lead to improper tissue detection, causing automatic tissue registration to fail. Should this occur, manual tissue registration on Loupe Browser will be required.
- When loading the slide on the instrument, the gasket imprint marks the boundary of the tissue area and can be used to align the AOI on the CytAssist.

Handling Tissue Slides

- When immersing slides in reagent, ensure all tissue sections are immersed. DO NOT submerge slide label.
- Maintain tissue slides in a low moisture environment such as a desiccator, avoid exposure to direct light, and keep at room temperature.
- Tissue slides that have been incubated at 42°C for 3 h and dried overnight at room temperature in a desiccator can be stored for up to two weeks at room temperature in a desiccator.
- Always wear gloves when handling slides.
- DO NOT touch the tissue sections on the slide.
- Minimize exposure of the slides to sources of particles and fibers.
- Keep the slide flat on the bench when adding reagents.
- Ensure that no absorbent surface is in contact with the reagents on the slide during incubation.

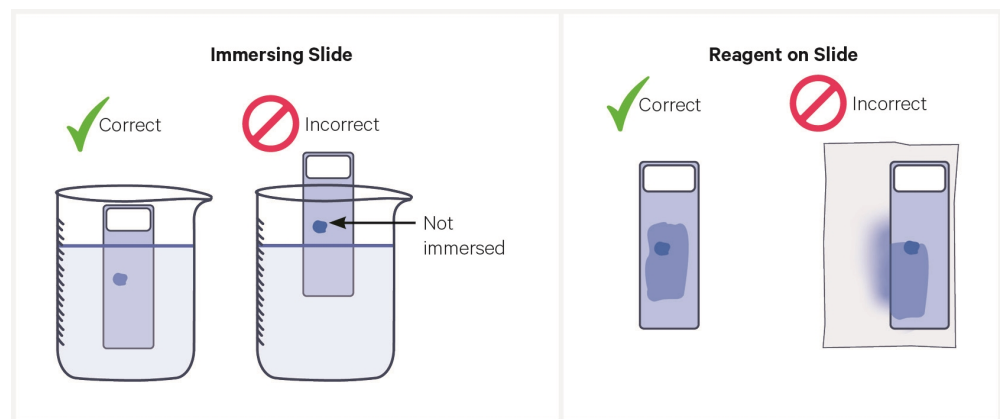

- DO NOT use a hydrophobic barrier (such as one applied by a PAP pen) on slides. These barriers may affect assay performance.
- Tissue slides may be annotated to highlight an AOI. See [Optional - Area of Interest Annotation on page 11](#) for more information.

Tissue Slide Incubation

Choose one of the following methods.

Incubation using a Section Dryer Oven:

- Place tissue slides in a slide drying rack on its side to prevent melted paraffin wax from disturbing adjacent tissue sections (if applicable).
- Close the lid when incubating tissue slides in the oven.

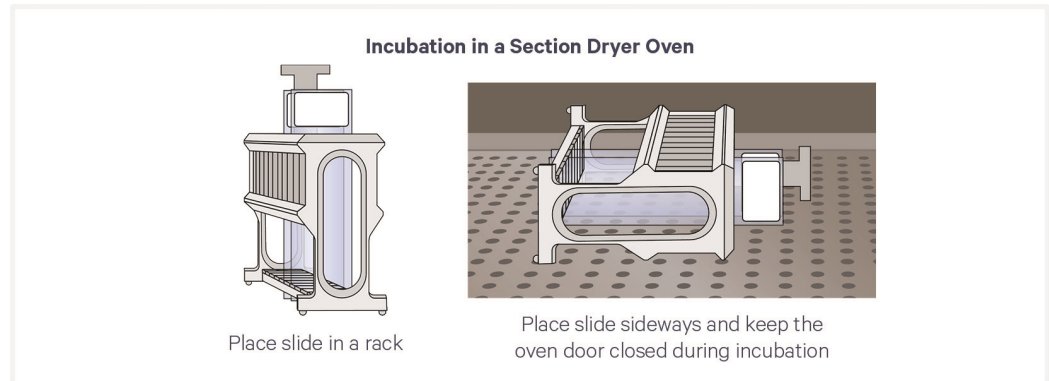

Incubation using a Thermal Cycler:

- Position a Low Profile Thermocycler Adapter on a thermal cycler that is set at the incubation temperature. Low Profile Thermocycler Adapter must come to temperature before placing tissue slide.
- Ensure that the Low Profile Thermocycler Adapter is in contact with the thermal cycler surface uniformly. Consult the Visium HD Protocol Planner (CG000698) for information on thermal cycler compatibility.
- When incubating a tissue slide, position tissue slides on the Low Profile Thermocycler Adapter with the side with tissue facing up.
- Ensure that the entire bottom surface of tissue slides is in contact with the Low Profile Thermocycler Adapter.
- If the tissue slide is within a cassette, ensure that the cassette sits flush with the Low Profile Thermocycler Adapter.
- DO NOT close the thermal cycler lid when incubating tissue slides.
- Allow Low Profile Thermocycler Adapter to cool before removing from thermal cycler.

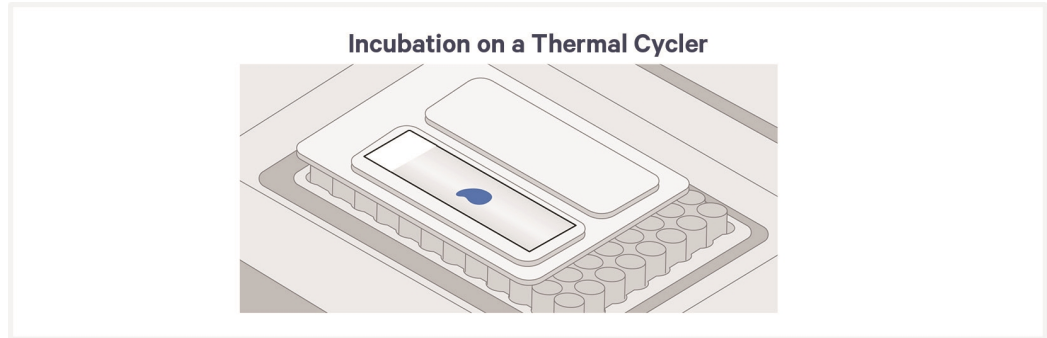

Reagent Addition to & Removal from Wells

Reagent Addition

- Assemble slide into the cassette flat on a clean work surface.
- Dispense and remove reagents along the side of the wells without touching the slide surface, tissue sections (when applicable), and without introducing bubbles.
- If applicable, perform washes next to the thermal cycler to avoid significant changes in temperature during washes.
- When processing two or more Visium Tissue Slide Cassettes, remove and add reagent from the first cassette before proceeding to the next cassette. Ensure tissue sections are always covered with reagent in between removal and addition steps to avoid drying out of tissue samples.
- Always cover the Capture Area or tissue completely when adding reagents to the well. A gentle tap may help spread the reagent more evenly.



Reagent Addition/Removal

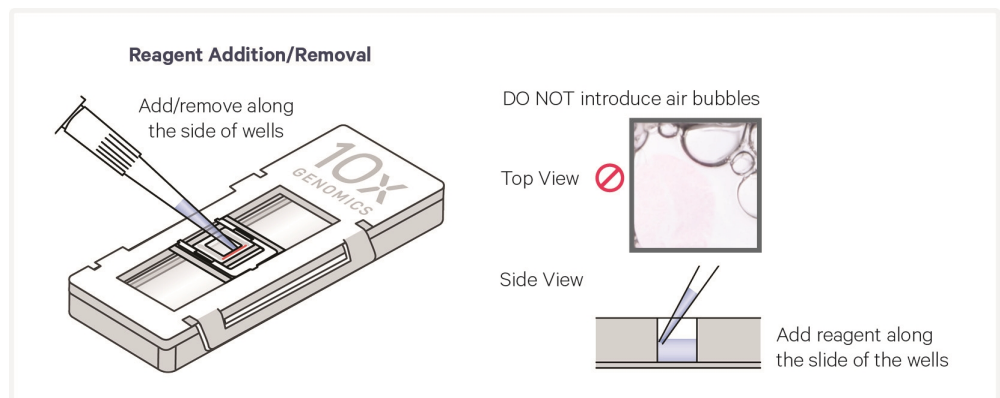

Reagent Removal from Wells

- Assemble slide into the cassette flat on a clean work surface.
- Slightly tilt the cassette while removing the reagent.
- Place the pipette tip on the bottom edge of the wells.
- Remove reagents along the side of the wells without touching the tissue sections (when applicable) and without introducing bubbles.
- Remove all liquid from the wells in each step. To ensure complete removal, check the bottom of the well by tilting the cassette slightly. A meniscus at the bottom of the well will indicate the presence of liquid in the well. Repeat removal steps until no reagent remains.

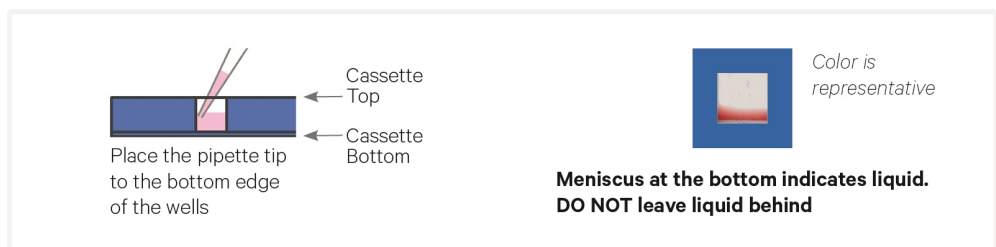

Visium Slide Seal Application & Removal

Application

- If applying a Visium Slide Seal to a Tissue Slide Cassette, the seal must be cut in half lengthwise. Cut the seal as shown in the image below. Five pre-cut seals per tissue slide are necessary for this assay.

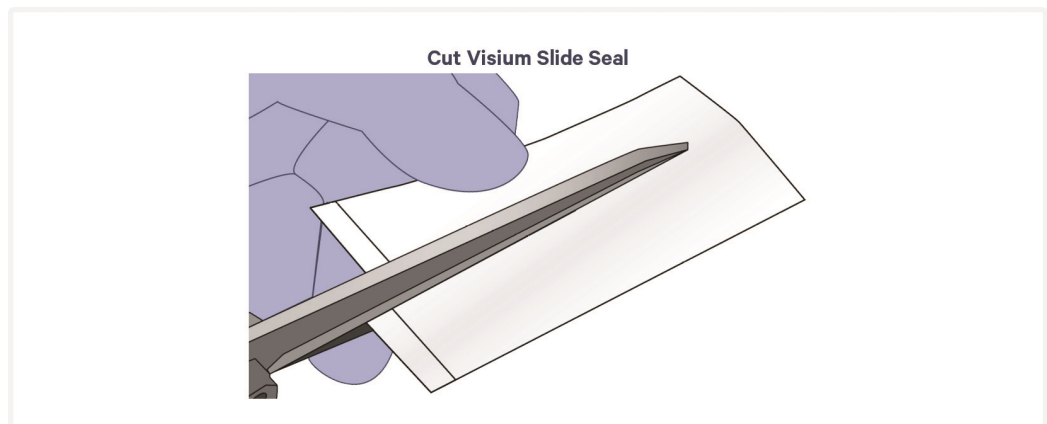

- Place the cassette flat on a clean work surface. Ensure surface of cassette is dry.
- Remove the back of the adhesive Visium Slide Seal.
- Align the Visium Slide Seal with the surface of the cassette and apply while firmly holding the cassette with one hand.
- Press on the Visium Slide Seal to ensure uniform adhesion.
- Use a fresh Visium Slide Seal when prompted during the protocol. Steps that do not require a new slide seal will specify that the slide seal should be pulled back and reapplied instead.

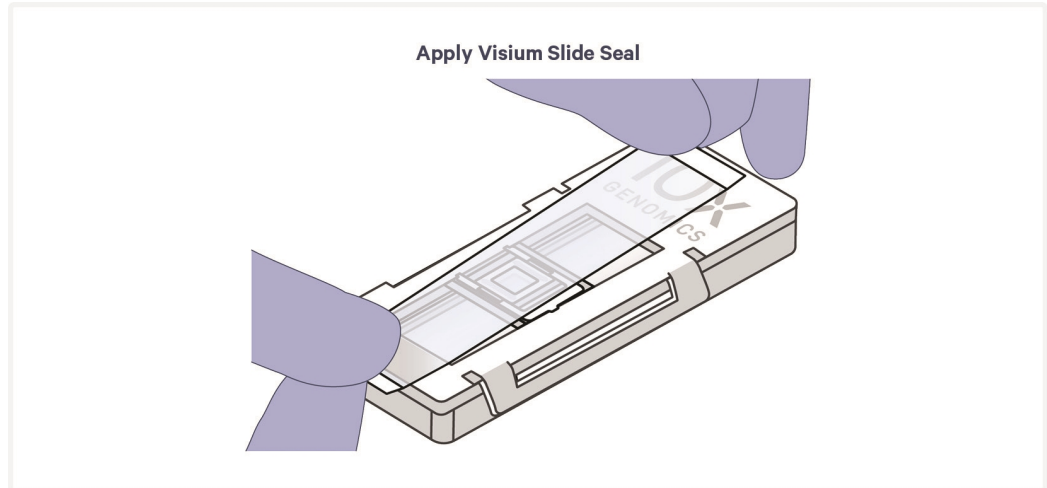

Removal

- Place the cassette flat on a clean work surface.
- Grab a Visium Slide Seal corner. Carefully pull on the Visium Slide Seal up and across the cassette while firmly holding the cassette. Ensure that no liquid splashes out of the wells. Movement of the gasket during slide seal removal could damage the tissue section.

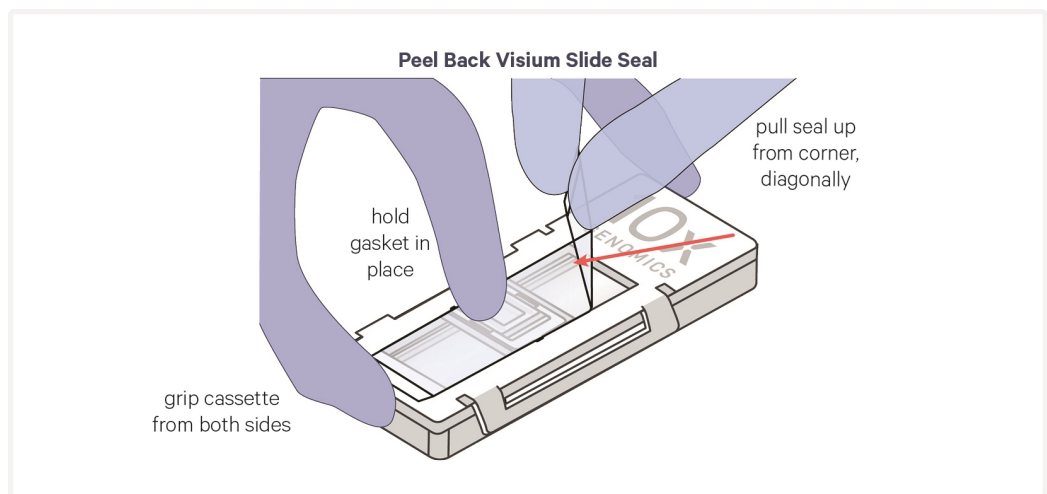

Handbook Overview and Navigation

Overview

This handbook describes sample preparation for the Visium HD Spatial Gene Expression workflow. Tabs on the right-hand side of the page denote different sections of this handbook. There are two major sample types that are compatible with the workflow: archived slides and freshly placed FFPE sections.

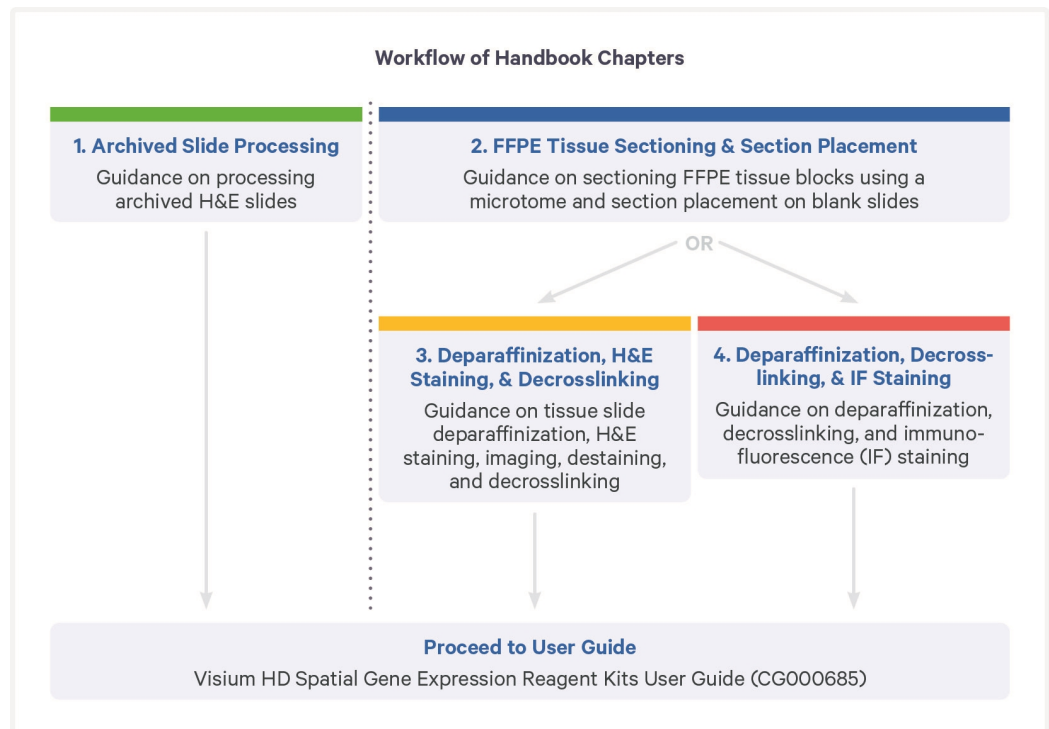

Archived Slides

Section one covers processing archived slides that were previously H&E stained and imaged. Archived slides have their coverslips removed, RNA assessed, and are destained and decrosslinked. After decrosslinking, slides are ready for the Visium HD workflow.

Freshly Placed FFPE Sections

Section two covers how to section and place FFPE tissue sections onto blank slides. After section placement, proceed to either section three for

H&E staining or section four for IF staining. After completing either staining protocol, slides are ready for the Visium HD workflow.

1. Archived Slide Processing

Overview

This chapter provides guidance on processing archived H&E slides. Archived slides are slides with FFPE tissue sections and a hardset mounted coverslip. These slides are in contrast to slides with freshly placed FFPE sections, as described in [2.3 Section Placement on page 39](#). Archived slides should have been stained, imaged, and stored at room temperature or 4°C. Over time, archived slides may experience RNA degradation; thus, freshly placed FFPE tissue sections are preferred for the Visium HD assay. Only archived slides that have been H&E stained have been tested with the Visium HD workflow.

RNA quality assessment should be performed on archived slides derived from the same tissue block as the slide that will be used for the full Visium HD assay. If this is not possible, an unimportant area of the section for processing can be scraped to assess RNA quality.

Before hardset coverslip removal, verify that images of archived slides meet the specifications required for analysis as specified in Visium HD Spatial Applications Imaging Guidelines Technical Note (CG000688). If images are absent or incompatible, before hardset coverslip removal, image the archived slide according to imaging guidelines.

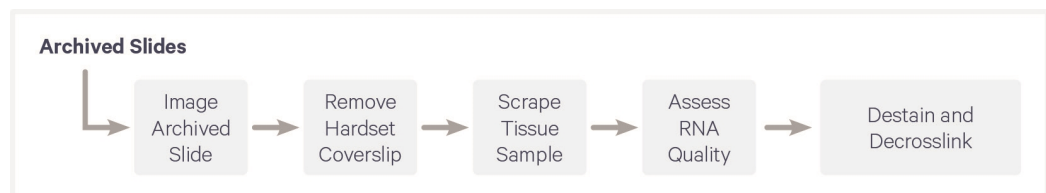

Remove Hardset Coverslip

Archived slides are incubated in xylene followed by rapid freezing to remove coverslips without damaging tissue sections.

Scrape Tissue Sample

Once hardset coverslip is removed, a small portion from a proximal section or an unimportant area of tissue from the section of interest is scraped to assess RNA quality.

Assess RNA Quality

RNA quality is assessed by scraping off a portion of the tissue, extracting RNA, and calculating the DV200 score.

Mean RNA fragment size is a reliable determinant of RNA quality. This requires a measurement of the percentage of total RNA fragments >200 nucleotides (DV200) for RNA quality assessment upstream of library preparation. For more information on DV200, see Appendix 1: DV200 Performance and Recommendations.

Before starting RNA extraction, apply RNaseZap to a paper towel and wipe work surface, centrifuge rotor and shafts of the pipettes. Rinse with RNase-free water and then wipe dry. The electrodes of the Bioanalyzer can also be cleaned with RNaseZap by following Agilent decontamination procedure.

Destaining and Decrosslinking

After RNA quality assessment, H&E-stained slides have their hematoxylin removed via destaining. After destaining, tissue sections are decrosslinked to ensure that RNA molecules are accessible.

1.0 Preparation

Consult the Visium HD Spatial Applications Protocol Planner (CG000698) for a list of third-party items.



For Coverslip Removal and RNA Assessment

Items	Preparation & Handling	
Prepare fresh weekly. Process two slides per jar. Process no more than 20 slides before replacing reagents. Alternatively, use a slide staining dish. Adjust volumes of deparaffinization solutions and water accordingly and ensure volume fully covers tissue.		
<input type="checkbox"/>	Xylene	Label two Coplin jars or staining dishes as Xylene Jar 1 and 2. Dispense 30 ml xylene in each.
<input type="checkbox"/>	100% Ethanol	Label two Coplin jars or staining dishes as 100% Ethanol Jar 1 and 2. Dispense 30 ml 100% ethanol in each.
<input type="checkbox"/>	96% Ethanol	Label two Coplin jars or staining dishes as 96% Ethanol Jar 1 and 2. Dispense 30 ml 96% ethanol in each.
<input type="checkbox"/>	70% Ethanol	Label one Coplin jar or staining dish as 70% Ethanol Jar. Dispense 30 ml 70% ethanol.
<input type="checkbox"/>	Nuclease-free water	Label one Coplin jar or staining dish as Water Jar. Dispense 30 ml nuclease-free water.
Obtain		
<input type="checkbox"/>	100% Ethanol	-
<input type="checkbox"/>	1X PBS	Prepare 1X PBS from 10X stock.
<input type="checkbox"/>	Xylene	-
<input type="checkbox"/>	Metal Block	-
<input type="checkbox"/>	New Razor Blade	-
<input type="checkbox"/>	Dry Ice	-
<input type="checkbox"/>	0.2 ml 8-tube Strip	-
<input type="checkbox"/>	RNeasy FFPE Kit	RNeasy MinElute Spin Column, Buffer PKD, Proteinase K, DNase Booster Buffer, DNase I Solution, RBC Buffer, and RPE Buffer are contained in this kit.

For Destaining

Items	10x PN	Preparation & Handling	Storage	
Prepare fresh before use				
<input type="checkbox"/>	0.1 N HCl	-	Prepare 0.1 N HCl using nuclease-free water.	Ambient
<input type="checkbox"/>	TE Buffer, pH 8.0	-	-	Ambient

For Decrosslinking

Items	10x PN	Preparation & Handling	Storage	
Equilibrate to room temperature				
<input type="checkbox"/>	 Perm Enzyme B	3000553	Remove from -20°C shortly before use. Maintain at room temperature. Pipette mix, centrifuge briefly. DO NOT vortex.	-20°C
<input type="checkbox"/>	 Decrosslinking Buffer B	2001094	Pre-heat thermomixer or water bath to 37°C. Thaw in a thermomixer (300 rpm with shaking) or water bath for 30 min at 37°C during Destaining. Cool to room temperature for 5 min. Vortex for 30 sec and centrifuge briefly.	-20°C
Obtain				
<input type="checkbox"/>	Nuclease-free Water	-	-	Ambient
<input type="checkbox"/>	1X PBS	-	Prepare 1 ml 1X PBS from 10X stock.	Ambient
<input type="checkbox"/>	10% Tween-20	-	-	Ambient
<input type="checkbox"/>	8M Urea	-	-	Ambient

1.1 Hardset Coverslip Removal

Xylene incubation steps should be performed in a fume hood. Either Coplin jars or staining dishes may be used. If archived slides have been H&E stained, image the archived slide according to guidelines described in the Visium HD Spatial Applications Imaging Guidelines Technical Note (CG000688) and ensure they are compatible with the Space Ranger analysis pipeline prior to hardset coverslip removal.

- a. Cool a metal block on dry ice for **5–10 min**.
- b. Gently immerse archived slide in Xylene Jar 1. Secure the jar cap to prevent xylene loss.
- c. Incubate for **5 min**.
- d. Remove excess xylene from archived slide with a lint-free laboratory wipe.
- e. Place on pre-cooled metal block with the coverslipped tissue sections facing down.
- f. Wait **1 min**.

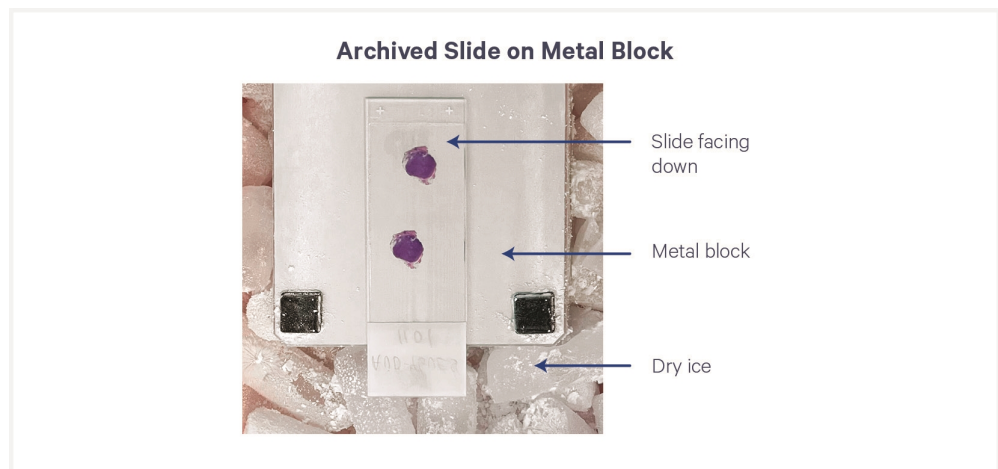

- g. Insert a clean blade a short distance between coverslip and archived slide on the shorter edge of the archived slide (see image below).



Work slowly in small steps, keeping the archived slide on the cold metal block in between steps. Avoid touching tissue with the blade. Exercise caution, as blade is sharp.

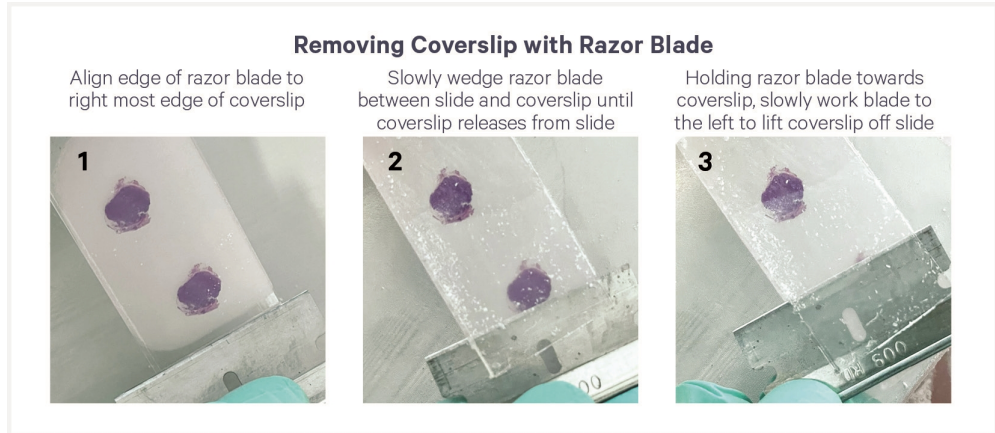

- h.** Gently immerse slides 2x in Xylene Jar 1, then immerse and incubate for **10 min.** Secure jar cap to prevent xylene loss.
- i.** Gently immerse slides 2x in Xylene Jar 2, then immerse and incubate for **10 min.** Secure jar cap to prevent xylene loss.
- j.** Gently immerse slides 2x in 100% Ethanol Jar 1, then immerse and incubate for **3 min.**
- k.** Gently immerse slides 2x in 100% Ethanol Jar 2, then immerse and incubate for **3 min.**
- l.** Gently immerse slides 2x in 96% Ethanol Jar 1, then immerse and incubate for **3 min.**
- m.** Gently immerse slides 2x in 96% Ethanol Jar 2, then immerse and incubate for **3 min.**
- n.** Gently immerse slides 2x in 70% Ethanol Jar, then immerse and incubate for **3 min.**
- o.** Gently immerse slides 2x in Water Jar, then immerse and incubate for **20 sec.**
- p.** Remove excess water from archived slide carefully with a lint-free laboratory wipe. Do not touch tissue.
- q.** Select a small portion of the section that can be scraped for RNA quality assessment. Sections for RNA quality assessment should have a minimum size of 2 x 2 mm and minimum thickness of 5 μm . Practice scraping sections from test tissues.
- r.** Using a clean blade, scrape the small portion for RNA quality assessment in one motion, resulting in one curl.

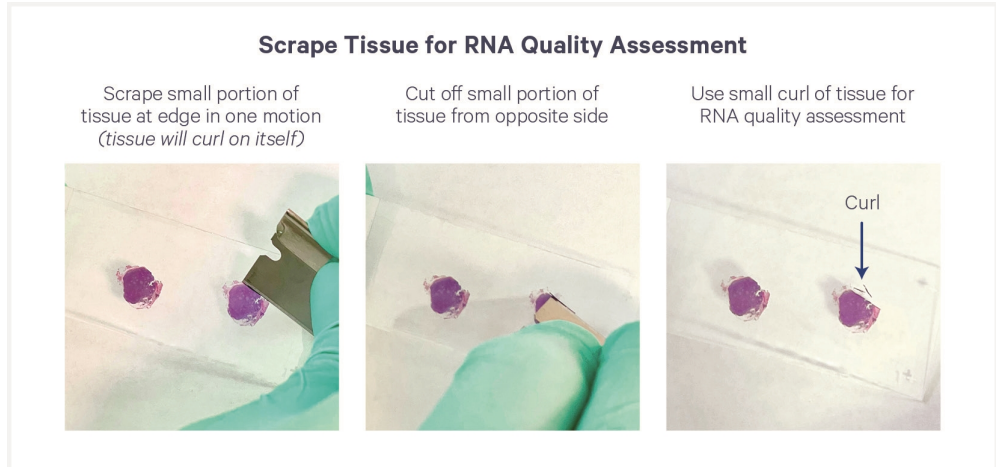

- s. Lift the curl using the blade, and use a clean pipette tip to transfer curl to one RNase-free 0.2-ml tube in a tube strip on ice. Store at **-80°C** for long-term storage or proceed immediately to RNA Extraction. If processing multiple archived slides, curls can be kept in tube strips on ice until ready for RNA extraction.
- t. The remaining section on the archived slide may be used for the Visium HD workflow. If necessary, store the slide in a sealed slide mailer in a desiccator kept in the dark at **4°C** for up to **two hours** to allow time for RNA evaluation.

1.2 RNA Extraction

- a. Prepare the thermal cycler with the following incubation protocol and start the program.

Lid Temperature	Reaction Volume	Run Time
80°C	160 µl	30 min
Step	Temperature	Time hh:mm:ss
Pre-equilibrate	56°C	Hold
Incubation 1	56°C	00:15:00
Incubation 2	80°C	00:15:00

- b. Add **150 µl** of Buffer PKD to sample tube and pipette mix.
- c. Add **10 µl** of Proteinase K to sample tube and pipette mix.
- d. Add sample tube to thermal cycler and skip Pre-equilibrate step.
- e. Pipette mix every **5 min** (pipette set to 120 µl) during Incubation 1 and 2 steps. Pipette mix without removing tube from block to prevent burns. Pipette mix gently to avoid generating bubbles.
- f. Incubate a 2-ml microcentrifuge tube on ice for **3 min**.
- g. Transfer sample to the pre-cooled 2-ml microcentrifuge tube after Incubation 2.
- h. Add **16 µl** of DNase Booster Buffer to tube.
- i. Add **10 µl** of DNase I Solution to tube. Pipette mix.
- j. Incubate at room temperature for **15 min**.
- k. Add **320 µl** of RBC Buffer to tube and pipette mix.
- l. Add **720 µl** of 100% Ethanol to tube and pipette mix.
- m. Transfer sample to RNeasy MinElute column. Do not allow sample to overflow in the column.
- n. Centrifuge column for **15 sec** at **8,000 rcf**.
- o. Repeat steps m-n until all sample has passed through the column.
- p. Add **500 µl** of RPE Buffer to column.
- q. Centrifuge column for **2 min** at **8,000 rcf**.
- r. Transfer column to a new 2-ml microcentrifuge tube.

- s. Centrifuge column for **5 min** at **maximum speed** with column lid open.
- t. Transfer column to a new 2-ml microcentrifuge tube.
- u. Add **12 µl** of nuclease-free water to column.
- v. Centrifuge column for **1 min** at maximum speed.
- w. Using a Nanodrop or Qubit Fluorometer, measure RNA concentration to determine the appropriate dilution for DV200 evaluation using the RNA 6000 Pico Kit or TapeStation High Sensitivity Kit. RNA outside of the recommended concentration may lead to inaccurate DV200 evaluation.
- x. Store purified RNA at **-80°C** for **long-term** storage or immediately proceed to DV200 evaluation using either the Agilent RNA 6000 Pico Kit or TapeStation High Sensitivity Kit. Follow manufacturer's instructions (Agilent) for DV200 evaluation.

For more information on DV200, see [DV200 Performance and Recommendations on page 88](#).

After DV200 evaluation, proceed with [1.3 Destaining on the next page](#).

1.3 Destaining

- a. Place a Low Profile Thermocycler Adapter in the thermal cycler. Prepare the thermal cycler with the following incubation protocol and start the program.

Lid Temperature	Reaction Volume	Run Time
42°C (lid may be set to lowest temperature if instrument does not enable 42°C)	100 µl	15 min

Step	Temperature	Time hh:mm:ss
Pre-equilibrate	42°C	Hold
Destaining	42°C	00:15:00
Hold	22°C	Hold

- b. Place the slide in a Tissue Slide Cassette.
See Visium Cassette S3 Quick Reference Card (CG000730) for assembly instructions. Practice assembly with a blank slide.
- c. Add **150 µl** 0.1 N HCl along the side of the wells to uniformly cover the tissue sections, without introducing bubbles. Tap cassette gently to ensure uniform coverage.
- d. Remove HCl from the wells.
- e. Add **100 µl** 0.1 N HCl along the side of the wells to uniformly cover the tissue sections, without introducing bubbles. Tap cassette gently to ensure uniform coverage.
- f. Apply pre-cut slide seal on cassette and place the cassette on the Low Profile Thermocycler Adapter at **42°C**.
- g. Close the thermal cycler lid. Skip Pre-equilibrate step to initiate Destaining.
- h. Remove the cassette from the Low Profile Thermocycler Adapter and place on a flat, clean work surface. Some color remaining in the tissue after thermal cycler incubation is normal.

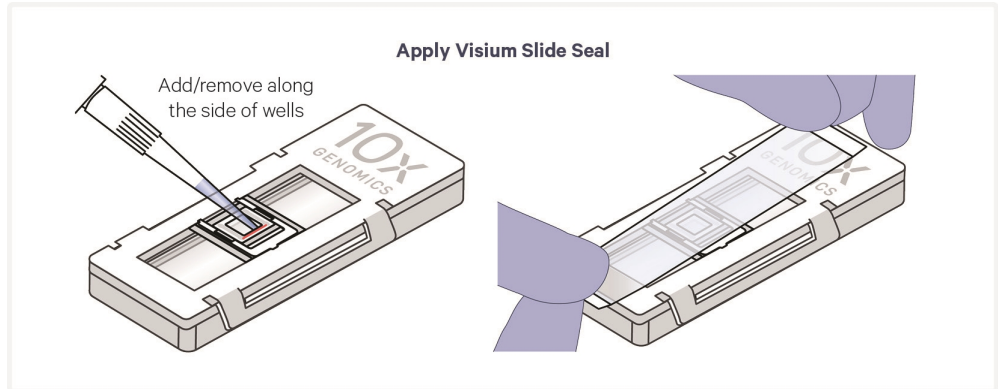

- i.** Remove slide seal. and using a pipette, remove all the HCl from the well corners.

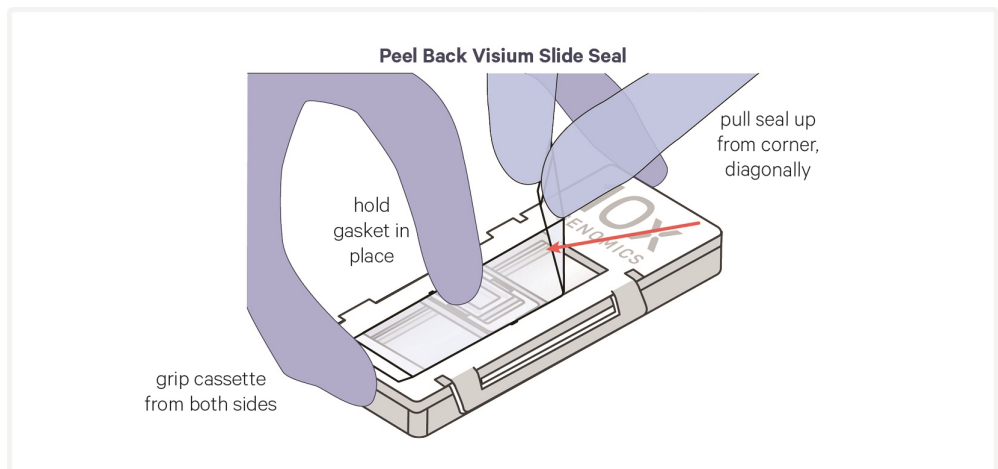

- j.** Add **150 μ l** TE Buffer (pH 8.0) along the side of the wells.
- k.** Incubate for **5 min.**
- l.** Remove TE Buffer from the wells.
- m.** Repeat j-l twice more for a total of three washes.
- n.** Add **100 μ l** 1X PBS along the side of the wells.
- o.** Proceed directly to Decrosslinking.

1.4 Decrosslinking

- a. Prepare the thermal cycler with the following incubation protocol and start the program.

Lid Temperature	Reaction Volume	Run Time
80°C	100 µl	40 min
Step	Temperature	Time hh:mm:ss
Hold	22°C	Hold
Decrosslinking	80°C	00:30:00
Re-equilibrate	22°C	00:10:00
Hold	22°C	Hold

- b. Prepare Diluted Perm Enzyme B according to the table below. Add reagents in the order listed. Mix thoroughly with a 1-ml pipette set to 600 µl. Maintain at room temperature.

Diluted Perm Enzyme B	Stock	Final	Total Amount (µl)
1X PBS	-	-	998.0
Perm Enzyme B <i>(Maintain at room temperature. Pipette mix, centrifuge briefly. DO NOT vortex).</i>	-	-	2.0
Total	-	-	1,000.0

- c. Prepare Decrosslinking Mix according to the table below. Add reagents in the order listed. Pipette mix thoroughly. Centrifuge briefly. Maintain at room temperature in the dark.

Decrosslinking Mix <i>1 slide = 1 Tissue Slide</i>	Stock	Final	1 slide (µl)	2 slides + 10% (µl)	4 slides + 10% (µl)
Decrosslinking Buffer B	-	-	92.50	203.50	407.00
Urea	8 M	0.5 M	6.25	13.75	27.50
Diluted Perm Enzyme B	-	-	1.25	2.75	5.50
Total	-	-	100.00	220.00	440.0

- d. Remove 1X PBS from the wells.
- e. Add **100 µl** Decrosslinking Mix along the side of the wells

- f.** Apply a new slide seal on the cassette and place the cassette on the Low Profile Thermocycler Adapter.
- g.** Close and tighten thermal cycler lid. Skip Pre-equilibrate step and initiate Decrosslinking.
- h.** Proceed **immediately** to Visium HD Spatial Gene Expression Reagent Kits User Guide (CG000685).

2. FFPE Tissue Sectioning & Section Placement

Overview

This chapter provides guidance on sectioning FFPE tissue blocks using a microtome and section placement on blank slides using a water bath.

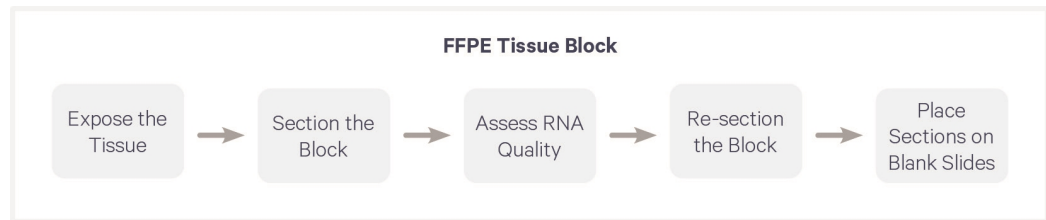

Exposing the Tissue

FFPE tissue block is placed in a microtome and cut to expose the tissue or face the block.

Sectioning

Sections are taken from the block for RNA quality assessment.

RNA Quality Assessment

RNA quality of the tissue is assessed by calculating DV200 of RNA extracted from freshly collected tissue sections.

Re-sectioning

A microtome sections the tissue block to generate sections for the blank slides.

Section Placement

Sections are collected in a water bath and are allowed to float on the water surface until they are flat and free from wrinkles and folds. The optimal floating time depends upon the specific tissue type and should be empirically determined when working with new tissue types. Expanded sections are then placed on blank slides.

Practice section placement using a nonexperimental block before proceeding with tissue slides for the Visium HD Spatial Gene Expression workflow. Each tissue slide must only be used for one CytAssist instrument run. DO NOT rerun tissue slides as this could affect assay performance.

2.0 Exposing the Tissue or Facing the Block

Before starting, wipe down all surfaces and work areas with RNaseZap RNase decontaminating solution.

- a. Remove tissue blocks from storage. For a tissue block with already exposed tissue, proceed directly to [2.1 RNA Quality Assessment of FFPE Tissue Block on the next page](#).
- b. Set the microtome to the 15 μm setting.
- c. Place tissue block on the specimen clamp.
- d. Cut the tissue block at 15 μm until all of the edges of the tissue are exposed or until the area of interest is exposed. The block should be at **room temperature** during cutting.

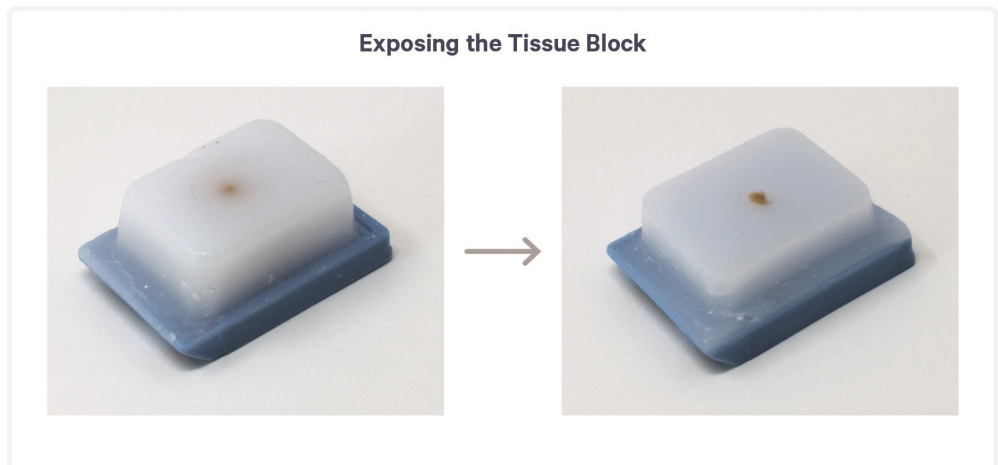

2.1 RNA Quality Assessment of FFPE Tissue Block

This section provides guidance on determining the RNA quality of the tissue block by calculating DV200 of RNA extracted from freshly collected tissue sections.

Mean RNA fragment size is a reliable determinant of RNA quality. This requires a measurement of the percentage of total RNA fragments >200 nucleotides (DV200) for RNA quality assessment upstream of library preparation. For more information on DV200, see [DV200 Performance and Recommendations on page 88](#).

Before starting RNA extraction, apply RNaseZap to a paper towel and wipe work surface, centrifuge rotor and shafts of the pipettes. Rinse with RNase-free water and then wipe dry. The electrodes of the Bioanalyzer can also be cleaned with RNaseZap by following Agilent decontamination procedure.

- a. Set microtome to 10 μm setting and collect tissue sections for RNA extraction. Discard the first few sections if the block was already exposed. The required number of sections depends upon tissue size. Consult RNA extraction kit manufacturer instructions to determine the appropriate number of sections. See below for guidance:
 - Collect ~4 sections for smaller tissues ($\leq 6.5 \times 6.5 \text{ mm}$)
 - Collect 1-2 sections for larger tissues ($\geq 6.5 \times 6.5 \text{ mm}$)
- b. Place the sections inside a **pre-cooled**, RNase-free microcentrifuge tube. Sections may be stored at **-80°C** for **long-term** storage. For sections stored at **-80°C**, equilibrate to **room temperature** for **5 min** before adding the deparaffinization solution.
- c. Proceed to RNA extraction using RNeasy FFPE Kit and follow manufacturer's instructions.
- d. Using a Nanodrop or Qubit Fluorometer, measure RNA concentration to determine the appropriate dilution for DV200 evaluation using the RNA 6000 Pico Kit or TapeStation High Sensitivity Kit. RNA outside of the recommended concentration may lead to inaccurate DV200 evaluation.
- e. Store purified RNA at **-80°C** for **long-term** storage or immediately proceed to DV200 evaluation using either the Agilent RNA 6000 Pico Kit or TapeStation High Sensitivity Kit. Follow manufacturer's instructions (Agilent) for DV200 evaluation.

2.2 Sectioning

- a. Place blocks in the ice bath, ensuring that the tissue part is fully submerged.
- b. Incubate on the ice bath for 10–30 min. The incubation time depends upon the tissue type and the extent of dehydration.



Monitor the exposed tissue every 5–10 min during the ice bath incubation. Overhydration may result in adhesion problems. The tissue surface should be smooth and shiny and free of bumps at the end of the incubation. For more information on tissue hydration, see Troubleshooting section.

FFPE Tissue Block in Ice Bath



- c. Carefully wipe off the excess oils from a 35X Ultra disposable blade using a lint-free laboratory wipe with 100% ethanol. Let the ethanol evaporate before proceeding. Always use new blades for sectioning each tissue type.



- d. Secure blade in disposable blade holder of the microtome and place knife guard over the blade to minimize injury. Ensure that the clearance angle is set to 10°.
- e. After hydration is complete, place the tissue block in the specimen clamp and align it with the blade.
- f. Fill up a water bath with Milli-Q or ultrapure water and ensure that the temperature is set at 42°C and free from bubbles & particulates by gliding a lint-free laboratory wipe over the water surface. Repeat this step between sectioning if necessary.



42°C is the recommended water bath temperature for most tissues. See Tips & Best Practices for guidance on optimizing water bath temperature. To visualize the tissue sections better, a Lighted Tissue Floating Bath with LED illumination can be used instead of standard water bath.

Remove Bubbles

- g.** Set the microtome to 5 μm for tissue sectioning and begin sectioning. For tissue blocks with exposed tissue, discard the first few sections and start collection on the subsequent sections.
- h.** To collect sections, place the paintbrush tip slightly above and parallel to the blade. Lift the section by lightly touching the edge with the paintbrush while rotating the wheel handle.
- i.** With the help of the brush, pick the section up. Immediately place it on the water surface of the water bath, making sure that the brush tip goes underneath and away from the section.
- j.** Proceed directly to Section Placement.

2.3 Section Placement

Before proceeding with tissue slides intended for the Visium HD workflow, practice section placement using nonexperimental blocks. Consider the following:

- If placing multiple sections on the blank slide, ensure that sections do not overlap.
- If placing a large section, see [Optional - Area of Interest Annotation on page 11](#) for information on selecting an area of interest.
- a. Trace allowable area onto back of the blank slide with a laboratory marker before section placement to ensure compatibility. See [Section Placement on Blank Slides on page 9](#) for more information. Markings will need to be removed before alignment on the Visium CytAssist instrument. Failure to remove markings may result in registration failure due to interference from the marker imprint. This results in incorrect tissue detection.
- b. Allow sections to float for the time previously determined to be optimal.
- c. Hold the blank slide vertically by lifting the top of the blank slide and insert it into the water, aligning the allowable area with the surface of the water while keeping the blank slide straight.
- d. Using the paintbrush or the probe, maneuver the section to the allowable area.



If sections float away from the blank slide, the blank slide can also be dipped into the water bath before sections are placed in the water.

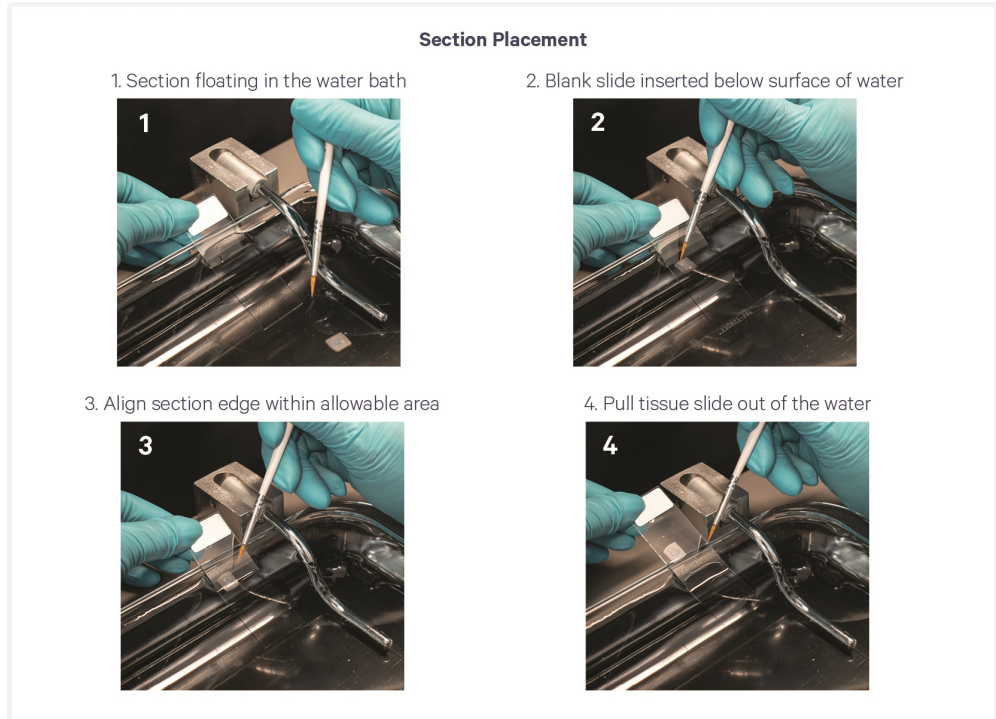

- e. Pull tissue slide up and out of the water, ensuring there are no air bubbles trapped underneath and set aside in a standing rack.
- f. Dry tissue sections upright at room temperature until tissue is opaque and no water remains on top of or under the section. A fan may be used to assist in drying. If no fan is used, slides may require extended drying time for up to **30 min** at **room temperature** to ensure no water remains under the section or until dry (inspect visually, DO NOT touch tissue).



- g.** Place the tissue slides in a slide drying rack in a section dryer and incubate for **3 h** in an oven at **42°C**. Alternatively, a thermal cycler set at **42°C** can be used for drying.



See Tips & Best Practices for guidance on slide incubation.

- h.** Place in a desiccator and keep overnight at **room temperature** to ensure proper drying.



- i.** After overnight drying, proceed with one of the staining protocols listed below or store the tissue slide containing dry tissue sections at **room temperature** or **4°C** in a desiccator for up to **6 months**.

Staining protocols:

- [3.2 H&E Staining on page 50](#)
- [4.3 Immunofluorescence Staining on page 73](#)

3. Deparaffinization, H&E Staining, & Decrosslinking

Overview

This chapter provides guidance on tissue slide deparaffinization, H&E staining, imaging, destaining, and decrosslinking for nonarchived tissue slides. These nonarchived tissue slides should be prepared according to [2. FFPE Tissue Sectioning & Section Placement on page 34](#) prior to starting this chapter. For archived slides, see [1. Archived Slide Processing on page 21](#)

Ensure that microscope settings have been verified and imaging programs have been created before starting this protocol. Consult the Visium HD Spatial Applications Imaging Guidelines Technical Note (CG000688) for more information. After completing Decrosslinking, proceed immediately to the Visium HD Spatial Gene Expression User Guide (CG000684).

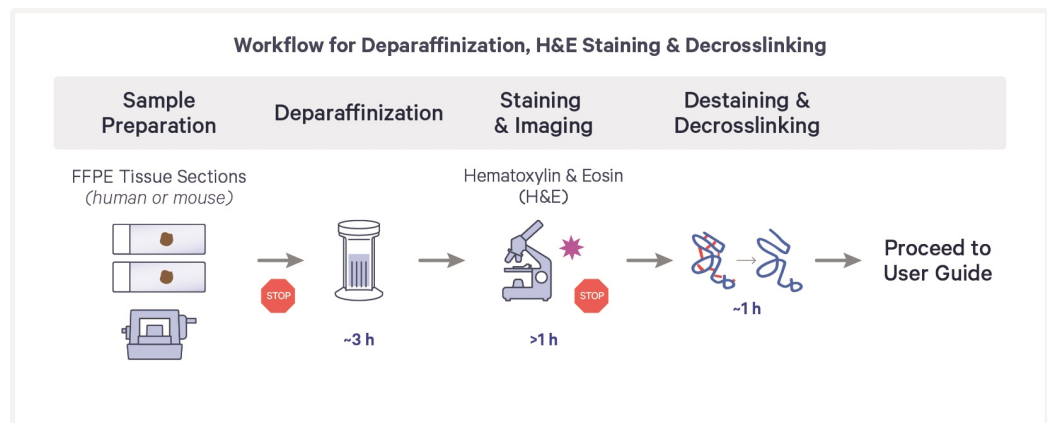

3.0 Preparation

Consult the Visium HD Spatial Applications Protocol Planner (CG000698) for a list of third-party items.

For Deparaffinization

Items	Preparation & Handling
Prepare fresh weekly. Process two slides per jar. Process no more than 20 slides before replacing reagents. Alternatively, use a slide staining dish. Adjust volumes of deparaffinization solutions and water accordingly and ensure volume fully covers tissue.	
<input type="checkbox"/> Xylene	Label two Coplin jars as Xylene Jar 1 and 2. Dispense 30 ml xylene in each.
<input type="checkbox"/> 100% Ethanol	Label two Coplin jars as 100% Ethanol Jar 1 and 2. Dispense 30 ml 100% ethanol in each. Alternatively, use a 50-ml centrifuge tube or beaker.
<input type="checkbox"/> 96% Ethanol	Label two Coplin jars as 96% Ethanol Jar 1 and 2. Dispense 30 ml 96% ethanol in each. Alternatively, use a 50-ml centrifuge tube or beaker.
<input type="checkbox"/> 70% Ethanol	Label one Coplin jar as 70% Ethanol Jar. Dispense 30 ml 70% ethanol. Alternatively, use a 50-ml centrifuge tube or beaker.
<input type="checkbox"/> Milli-Q or UltraPure Water	Label one Coplin jar as WaterJar. Dispense 30 ml water. Alternatively, use a 50-ml centrifuge tube or beaker.

For H&E Staining

Items	Preparation & Handling
<input type="checkbox"/> Milli-Q or UltraPure Water	Label six 1000-ml beakers as Water Beakers 1–6. Dispense 800 ml of water into each beaker. Dispensed volumes in each beaker can be used for two slides. Alternatively, use 50-ml centrifuge tubes instead of beakers.
<input type="checkbox"/> Alcoholic Eosin	Prepare 30 ml in a 50-ml conical tube for each tissue slide.
<input type="checkbox"/> Gill II Hematoxylin	
<input type="checkbox"/> Bluing Buffer	

For Imaging

Items	Preparation & Handling				
<input type="checkbox"/> Mounting Medium	The dilution below is not necessary if stock glycerol is already at 85%. Invert to mix. Briefly centrifuge to remove bubbles.				
Mounting Medium					
1 slide = 1 Tissue Slide	Stock	Final	1 Slide (μl)	2 Slides +15% (μl)	4 Slides +15% (μl)
Glycerol	100%	85%	127.5	293.3	586.5
Nuclease-free Water	-	-	22.5	51.7	103.5
Total	-	-	150.0	345.0	690.0

For Destaining

Items	10x PN	Preparation & Handling	Storage
Prepare shortly before use			
<input type="checkbox"/> 0.1 N HCl	-	Prepare 0.1 N HCl using nuclease-free water.	Ambient
<input type="checkbox"/> TE Buffer, pH 8.0	-	-	Ambient

For Decrosslinking

Items	10x PN	Preparation & Handling	Storage
Equilibrate to room temperature			
<input type="checkbox"/> Perm Enzyme B	3000553	Equilibrate to room temperature. Pipette mix, centrifuge briefly. DO NOT vortex.	-20°C
<input type="checkbox"/> Decrosslinking Buffer B	2001094	Pre-heat thermomixer or water bath to 37°C. Thaw in a thermomixer (300 rpm with shaking) or water bath for 30 min at 37°C during Destaining. Cool to room temperature for 5 min. Vortex for 30 sec and centrifuge briefly.	-20°C
Obtain			
<input type="checkbox"/> Nuclease-free Water	-	-	Ambient
<input type="checkbox"/> 1X PBS	-	Prepare 1 ml 1X PBS from 10X stock using nuclease-free water.	Ambient
<input type="checkbox"/> 10% Tween-20	-	-	Ambient
<input type="checkbox"/> 8M Urea	-	-	Ambient

Protocol Overview

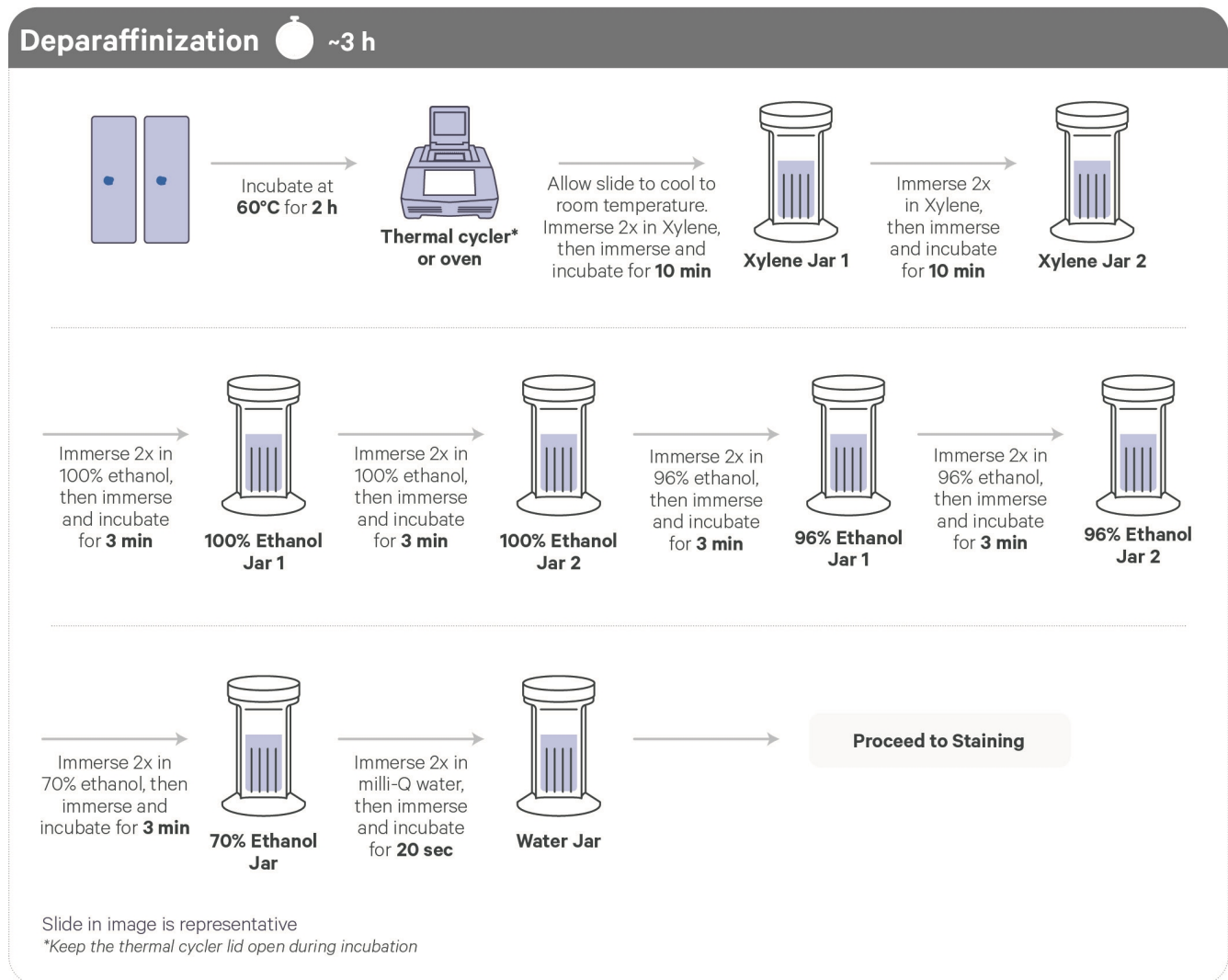

H&E Staining & Imaging

H&E Staining & Coverslipping ~15 min

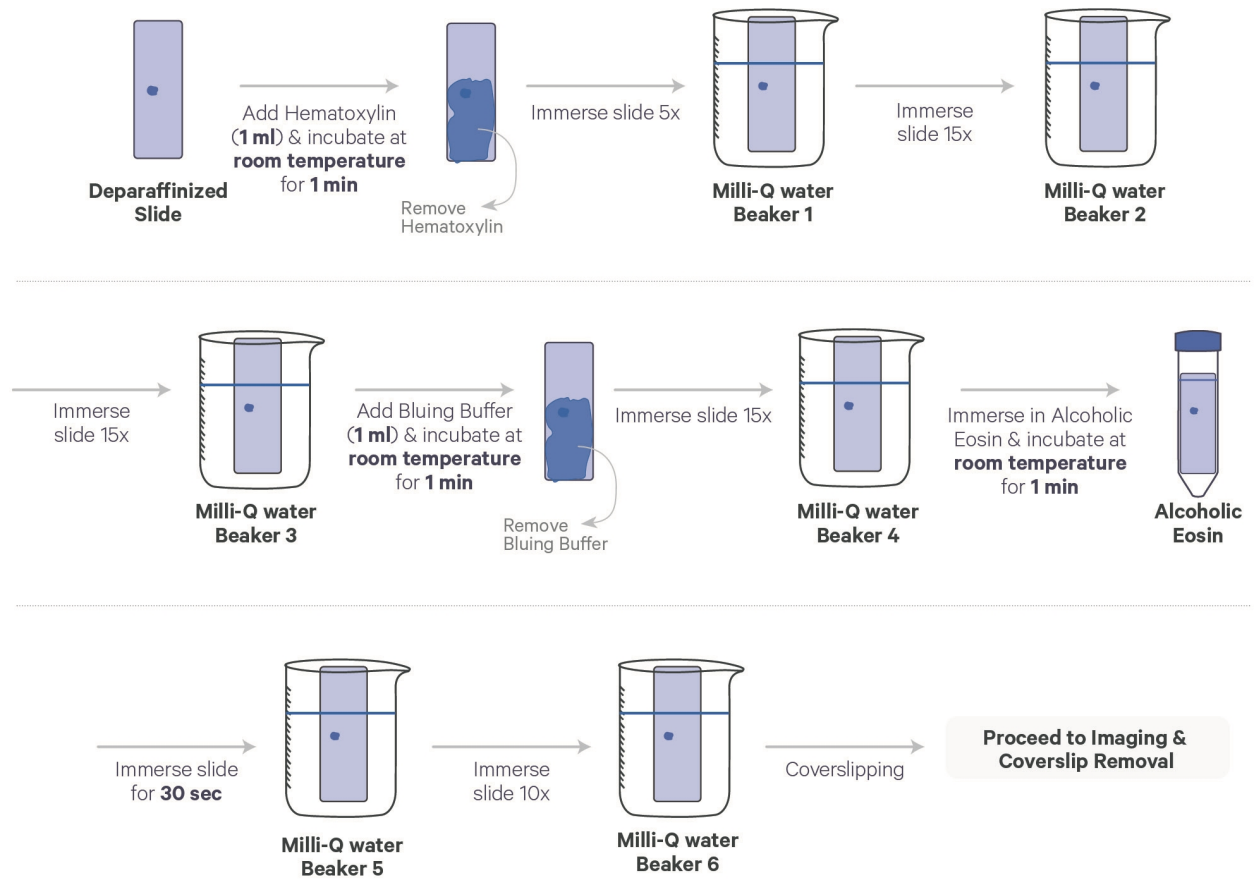

*Wipe excess liquid from the back of the slide after each immersion series

H&E Staining & Imaging

Destaining ~30 min

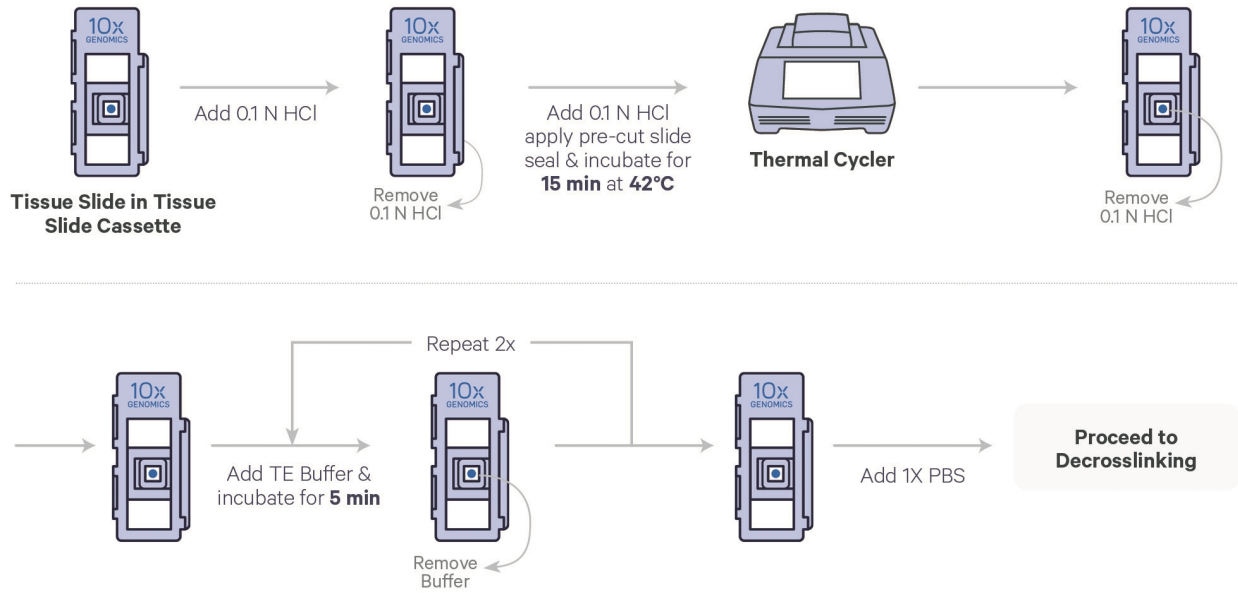

Decrosslinking ~30 min

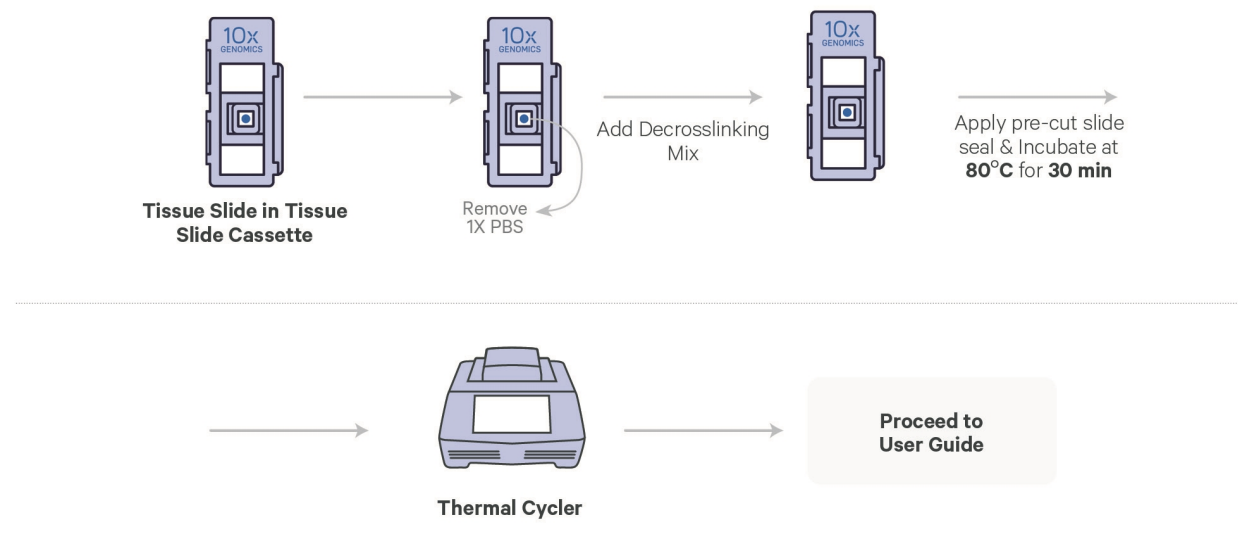

H&E Staining & Imaging

3.1 Deparaffinization

Deparaffinization steps should be performed in a fume hood due to the hazardous nature of xylene.

- a. Retrieve slides with tissue sections from desiccator after overnight drying.
- b. Place slides in a rack sideways in a Section Dryer Oven and incubate uncovered at **60°C** for **2 h**. Keep oven lid closed during incubation.

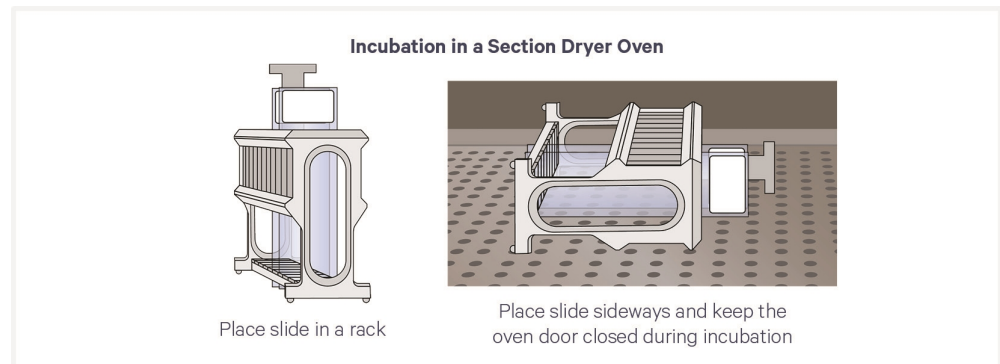

Alternatively, place a Low Profile Thermocycler Adapter on a thermal cycler set at **60°C**. Place slide on the Low Profile Thermocycler Adapter with the tissue side facing up and incubate **2 h** at **60°C**.



DO NOT close the thermal cycler lid.

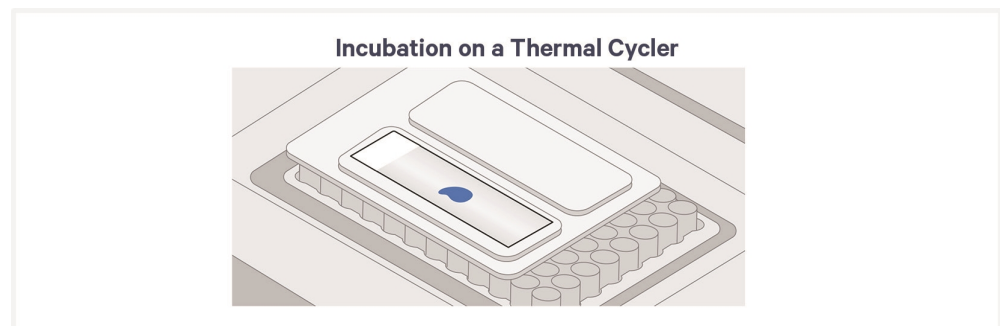

- c. Remove slides from the oven or thermal cycler and allow to cool down to room temperature for **5 min**. Exercise caution, as slides are hot.



When immersing slides in xylene, ensure that the tissue sections are completely submerged.

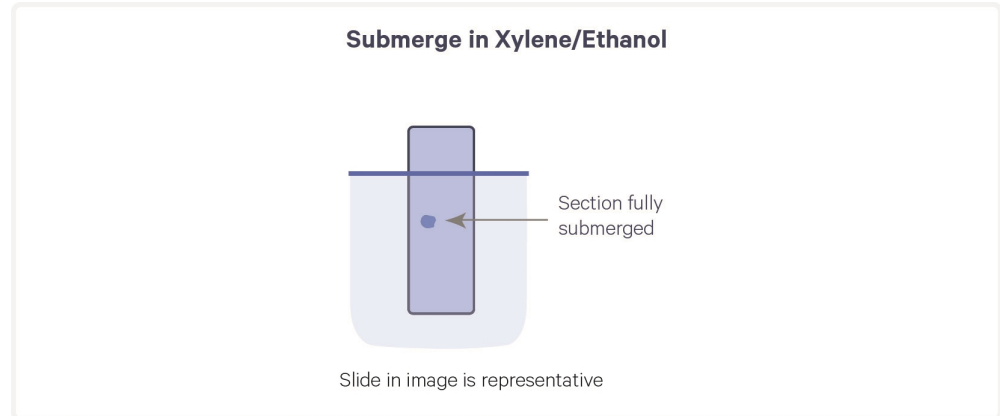

- d.** Gently immerse slides 2x in Xylene Jar 1, then immerse and incubate for **10 min.** Secure jar cap to prevent xylene loss.
- e.** Gently immerse slides 2x in Xylene Jar 2, then immerse and incubate for **10 min.** Secure jar cap to prevent xylene loss.
- f.** Gently immerse slides 2x in 100% Ethanol Jar 1, then immerse and incubate for **3 min.**
- g.** Gently immerse slides 2x in 100% Ethanol Jar 2, then immerse and incubate for **3 min.**
- h.** Gently immerse slides 2x in 96% Ethanol Jar 1, then immerse and incubate for **3 min.**
- i.** Gently immerse slides 2x in 96% Ethanol Jar 2, then immerse and incubate for **3 min.**
- j.** Gently immerse slides 2x in 70% Ethanol Jar, then immerse and incubate for **3 min.**
- k.** Gently immerse slides 2x in Water Jar, then immerse and incubate for **20 sec.**
- l.** Proceed **immediately** to Staining & Coverslip Mounting.



DO NOT let the slides dry.

3.2 H&E Staining

- a. Place on a flat, clean, nonabsorbent work surface. Some residual droplets may remain.
- b. Add **1 ml** Hematoxylin per slide to uniformly cover all tissue sections.
- c. Incubate **1 min** at **room temperature**.



- d. Discard reagent by holding slides at an angle with the bottom edge in contact with a lint-free laboratory wipe.
- e. Immerse slides 5x in Water Beaker 1.
- f. Immerse slides 15x in Water Beaker 2.
- g. Immerse slides 15x in Water Beaker 3.
- h. Wipe excess liquid from the back of the slides without touching the tissue section.
- i. Place on a flat, clean, nonabsorbent work surface. Some droplets may remain.
- j. Add **1 ml** Bluing Buffer per slide to uniformly cover all tissue sections.
- k. Incubate **1 min** at **room temperature**.
- l. Discard reagent by holding slides at an angle with the bottom edge in contact with a lint-free laboratory wipe.
- m. Immerse slides 15x in Water Beaker 4.
- n. Wipe excess liquid from the back of the slides without touching the tissue section. Place on a flat, clean, nonabsorbent work surface. Some droplets may remain.

- o.** Gently immerse the slides in alcoholic Eosin solution in separate 50 ml conical tubes.
- p.** Incubate **1 min** at **room temperature**. DO NOT use diluted Eosin.
- q.** Discard reagent by draining or holding slides at an angle with the bottom edge in contact with a lint-free laboratory wipe.
- r.** Immerse slides for **30 sec** in Water Beaker 5.
- s.** Immerse slides 10x in Water Beaker 6.
- t.** Wipe excess liquid from the back of the slides without touching the tissue section.



DO NOT air dry the slides.

3.3 Coverslip Mounting

- a.** Place slides on a flat, clean, nonabsorbent work surface. Some residual droplets may remain.
- b.** Using a **wide-bore** pipette tip, add **100–150 μ l** Mounting Medium to cover all tissue sections on slides uniformly.
- c.** Apply the coverslip at an angle on one end of the slides. Slowly lower the coverslip, without introducing bubbles. Allow Mounting Medium to spread and settle.

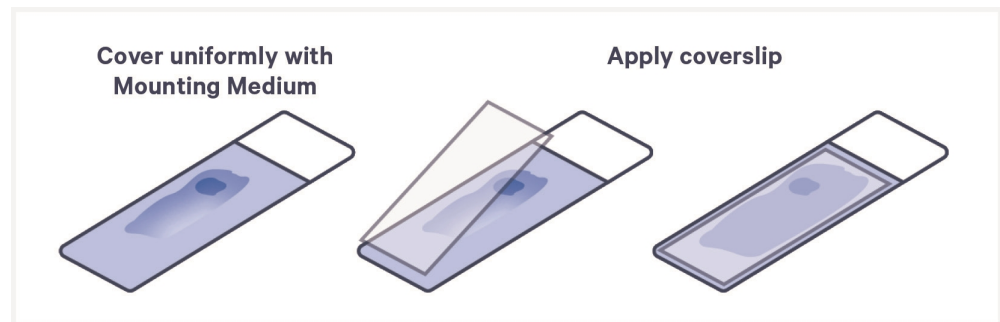

- d.** Remove any large excess of Mounting Medium by carefully wicking away from the edge of the coverslip using a lint-free laboratory wipe. Do not move the coverslip and disturb the tissue.
- e.** **Immediately** proceed with imaging or store slides laying flat in a slide mailer or a slide holder. Store slides at **4°C** for up to **24 h**. Ensure that slides are laid flat to prevent loss of mounting medium.



DO NOT let the attached coverslip dry out.

DO NOT use Cytoseal or nail polish for securing the coverslip.

3.4 Imaging

- a. Image tissue section of interest at the desired magnification using brightfield imaging settings. Consult the Visium HD Spatial Applications Imaging Guidelines Technical Note (CG000688) for additional information.
- b. Proceed **immediately** to Coverslip Removal.

3.5 Coverslip Removal

- a. Dispense **800 ml** Milli-Q water in a beaker. Up to 10 slides may be processed using this beaker.
- b. Immerse slides sideways in the beaker containing **800 ml** water with the coverslipped surface fully sideways to prevent the coverslip from dragging across the tissue.
- c. Hold slides in water until the coverslip slowly separates away from the slide.



To avoid tissue section damage or detachment, DO NOT move the slide up and down, shake forcibly, or manually move the coverslip.

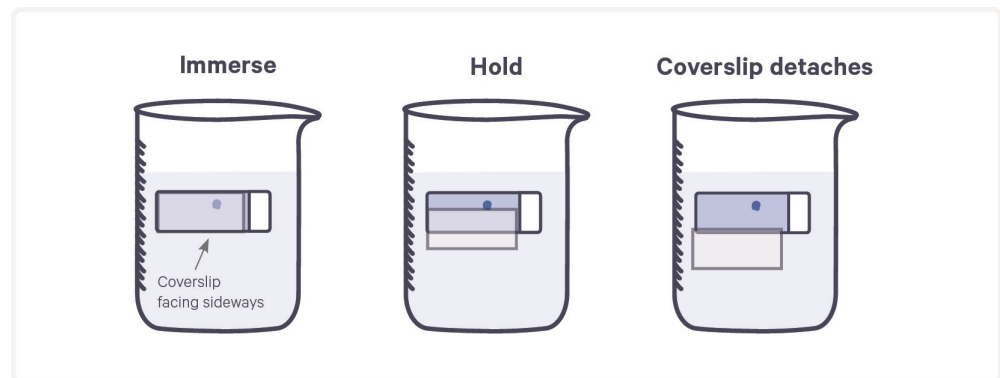

- d. Gently immerse slides 30x in water to ensure all Mounting Medium is removed.
- e. Wipe the back of the slide with a lint-free laboratory wipe. Place on a flat, clean, nonabsorbent work surface and air dry for **5 min**.
- f. Incubate slide on the Low Profile Thermocycler Adapter with thermal cycler lid open for **3 min** at **37°C** to dry the tissue and slide. Ensure tissue is completely dry. If necessary, wipe droplets around tissue with a lint-free laboratory wipe.
- g. Proceed **immediately** to Destaining or store slides laying flat in a slide



mailer or slide holder at **4°C** in the dark with desiccant for up to **2 weeks**. Ensure slides do not touch one another and that desiccant does not come in contact with the tissue slide.

3.6 Destaining

- a. Place a Low Profile Thermocycler Adapter in the thermal cycler. Prepare the thermal cycler with the following incubation protocol and start the program.

Lid Temperature	Reaction Volume	Run Time
42°C (lid may be set to lowest temperature if instrument does not enable 42°C)	100 µl	15 min

Step	Temperature	Time hh:mm:ss
Pre-equilibrate	42°C	Hold
Destaining	42°C	00:15:00
Hold	22°C	Hold

- b. Place the slide in a Tissue Slide Cassette.
See Visium Cassette S3 Quick Reference Card (CG000730) for assembly instructions. Practice assembly with a blank slide.
- c. Add **150 µl** 0.1 N HCl along the side of the wells to uniformly cover the tissue sections, without introducing bubbles. Tap cassette gently to ensure uniform coverage.
- d. Remove HCl from the wells.
- e. Add **100 µl** 0.1 N HCl along the side of the wells to uniformly cover the tissue sections, without introducing bubbles. Tap cassette gently to ensure uniform coverage.
- f. Apply pre-cut slide seal on cassette and place the cassette on the Low Profile Thermocycler Adapter at **42°C**.

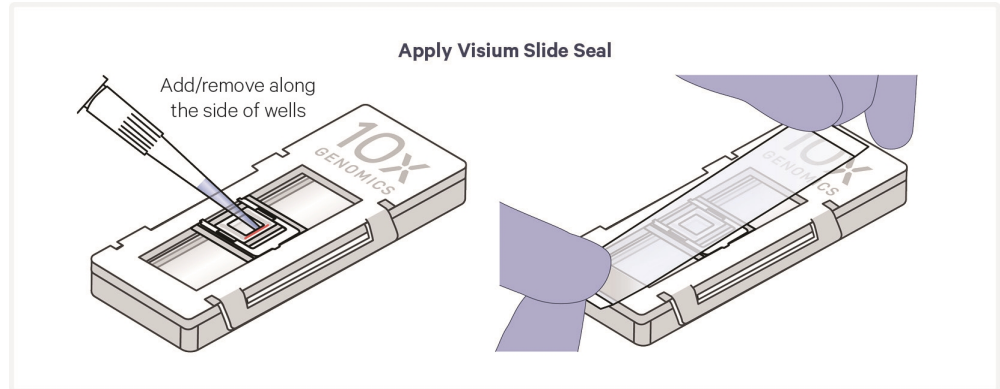

- g.** Close the thermal cycler lid. Skip Pre-equilibrate step to initiate Destaining.
- h.** Remove the cassette from the Low Profile Thermocycler Adapter and place on a flat, clean work surface. Some color remaining in the tissue after thermal cycler incubation is normal.
- i.** Remove slide seal and using a pipette, remove all the HCl from the well corners.

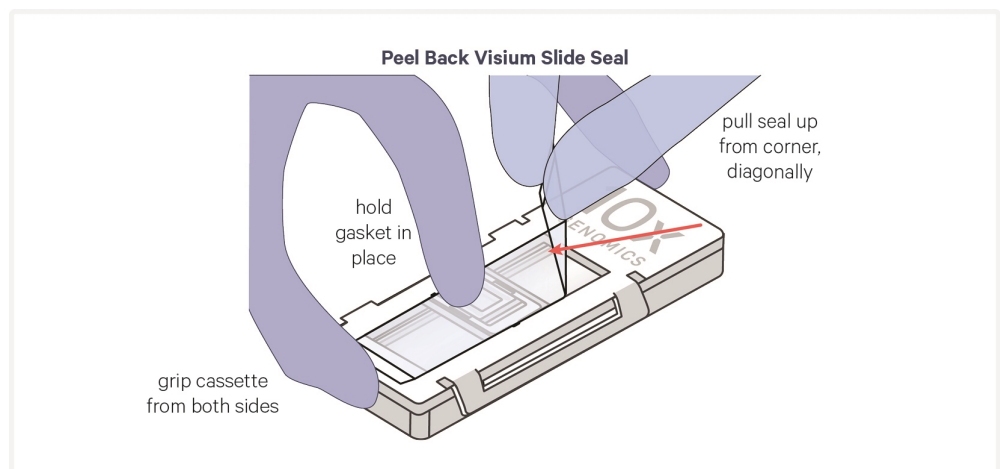

- j.** Add **150 μ l** TE Buffer along the side of the wells.
- k.** Incubate for **5 min**.
- l.** Remove TE Buffer from the wells.
- m.** Repeat j-l twice more for a total of three washes.
- n.** Add **100 μ l** 1X PBS along the side of the wells.

3.7 Decrosslinking

- a. Prepare the thermal cycler with the following incubation protocol and start the program.

Lid Temperature	Reaction Volume	Run Time
80°C	100 µl	40 min
Step	Temperature	Time hh:mm:ss
Hold	22°C	Hold
Decrosslinking	80°C	00:30:00
Re-equilibrate	22°C	00:10:00
Hold	22°C	Hold

- b. Prepare Diluted Perm Enzyme B according to the table below. Add reagents in the order listed. Mix thoroughly with a 1-ml pipette set to 600 µl. Maintain at room temperature.

Diluted Perm Enzyme B	Stock	Final	Total Amount (µl)
1X PBS	-	-	998.0
Perm Enzyme B <i>(Maintain at room temperature. Pipette mix, centrifuge briefly. DO NOT vortex).</i>	-	-	2.0
Total	-	-	1,000.0

- c. Prepare Decrosslinking Mix according to the table below. Add reagents in the order listed. Pipette mix thoroughly. Centrifuge briefly. Maintain at room temperature.

Decrosslinking Mix <i>1 slide = 1 Tissue Slide</i>	Stock	Final	1 slide (µl)	2 slides + 10% (µl)	4 slides + 10% (µl)
Decrosslinking Buffer B	-	-	92.50	203.50	407.00
Urea	8 M	0.5 M	6.25	13.75	27.50
Diluted Perm Enzyme B	-	-	1.25	2.75	5.50
Total	-	-	100.00	220.00	440.00

- d. Remove 1X PBS from the wells.
- e. Add **100 µl** Decrosslinking Mix along the side of the wells

- f.** Apply a new slide seal on the cassette and place the cassette on the Low Profile Thermocycler Adapter.
- g.** Close and tighten thermal cycler lid. Skip Pre-equilibrate step and initiate Decrosslinking.
- h.** Proceed **immediately** to Visium HD Spatial Gene Expression Reagent Kits User Guide (CG000685).

4. Deparaffinization, Decrosslinking, & IF Staining

Overview

This chapter provides guidance on deparaffinization, decrosslinking, and immunofluorescence (IF) staining for nonarchived tissue slides. These nonarchived tissue slides should be prepared according to [2. FFPE Tissue Sectioning & Section Placement on page 34](#) prior to starting this chapter. Archived IF slides have not been tested by 10x Genomics¹. [Archived Slide Processing on page 21](#) This chapter also provides guidance on optimizing antibodies.

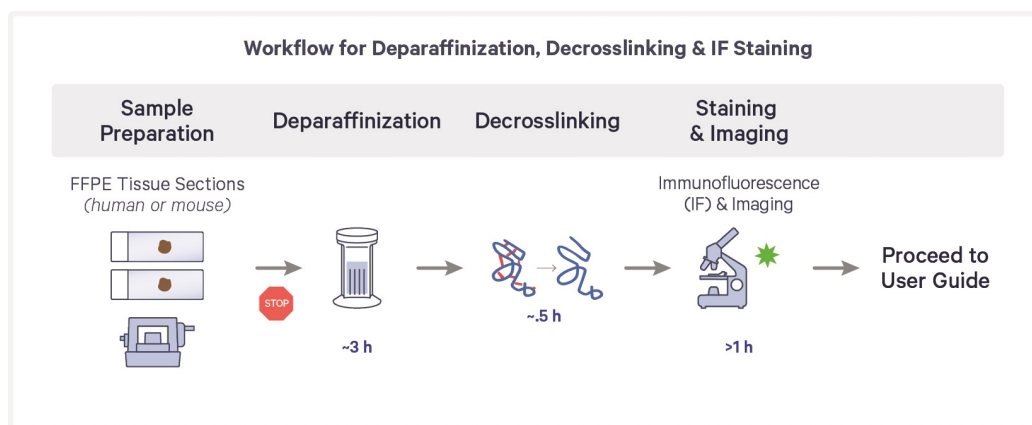

One additional Tissue Slide Cassette is required for each processed Tissue Slide (PN-1000684) to perform the assay.

Ensure that microscope settings have been verified and imaging programs have been created prior to starting this step. Consult the Visium HD Spatial Applications Imaging Guidelines Technical Note (CG000688) for more information.

If staining using fluorophore conjugated primary antibodies, proceed directly to [4.4 Immunofluorescence Staining - Fluorophore Conjugated Primary Antibodies on page 73](#) after completing [4.2 Decrosslinking on page 71](#).

If staining using primary and secondary antibodies, proceed directly to step [4.5 Immunofluorescence Staining - Primary & Secondary Antibodies on page 75](#) after completing [4.2 Decrosslinking on page 71](#).

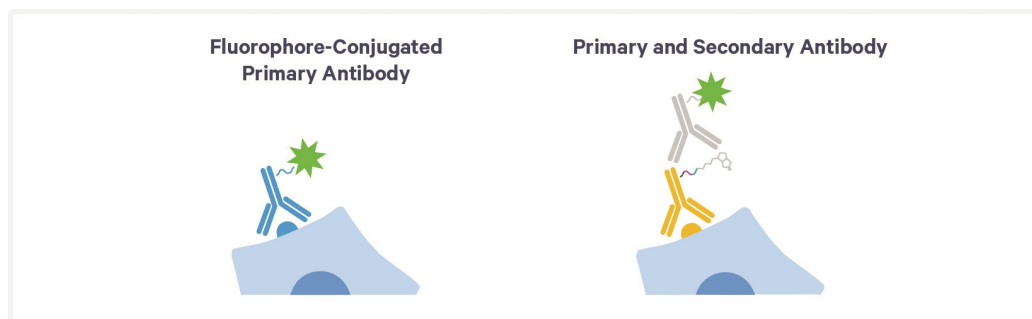

Antibody Optimization

Prior testing of the antibodies is recommended on the same tissue block before performing immunofluorescence staining in combination with the Visium HD Spatial Gene Expression workflow. Determination of the optimal antibody concentration is crucial for successfully executing this protocol.



A Visium 8-port Cassette S3, 4 pk (PN-1000685) must be purchased to perform antibody optimization.

The amount of Decrosslinking Buffer provided in the kit is enough to perform antibody optimization, while still leaving enough reagent for the main assay.

6.5 mm Slides		
Reagent	PN	Reactions* Available for Optimization
Decrosslinking Buffer B	2001094	8

*Reactions refers to the number of antibody dilutions that can be prepared, given the volume of each well in the Visium Cassette. For example, the example dilution series below tests seven antibody optimization reactions.

Optimal antibody concentrations for this Demonstrated Protocol may differ from other applications. Composition of reagents and buffers may also differ from other immunofluorescence applications.

Ensure that enough reactions are available for the main assay after running optimization experiments.

When optimizing the antibody for a single tissue type, ensure that stained slides can be imaged according to the imaging guidelines listed in Visium HD Spatial Applications Imaging Guidelines Technical Note (CG000688).

Below is a suggested optimization workflow. Antibody optimization may be performed according to preference, as long as tissues are tested using the immunofluorescence staining protocol described in this document.

- To optimize antibody concentration, draw representative frames on the back of a blank slide using the example slide layout for a 25 mm wide

slide.

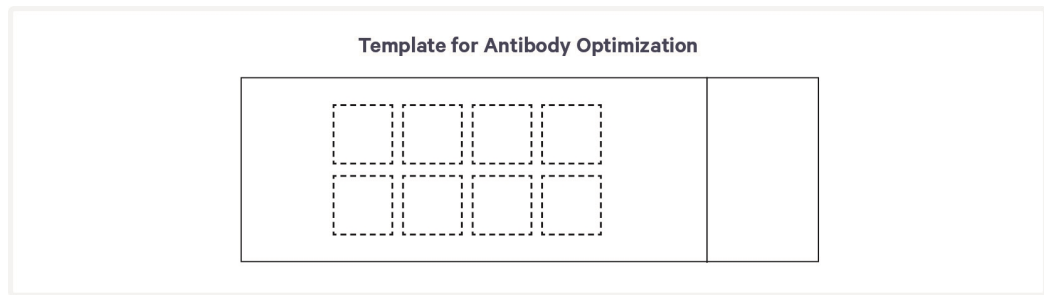

- Tissue sections must be trimmed to fit within each 6.5 mm area on the template.
- Place tissue sections in the frames on the front of the slide for compatibility with the Visium Cassette.
- Execute the Deparaffinization, Decrosslinking & Immunofluorescence Staining protocol using a range of antibody concentrations, testing multiple concentrations on the same tissue slide. A starting concentration of 0.01 $\mu\text{g}/\mu\text{l}$ (0.7 $\mu\text{g}/\text{sample}$) is recommended.
- To reduce autofluorescence, TrueBlack reagent may be added.
- Select the antibody concentration that results in the specific staining of desired cells, while minimizing nonspecific background staining.

Autofluorescence quenchers are added following immunofluorescence staining and may result in the reduction of fluorescence signal. Additional optimization and increase in antibody concentration may be required to properly visualize immunostaining.

An example dilution layout is provided below. DAPI and merged image are provided to show the presence of breast cancer tissue for each antibody dilution. Dilutions are of recombinant Anti-Vimentin antibody conjugated to Alexa Fluor 594 (BioLegend, PN677804, 0.5 mg/ml). A 1:100 dilution (0.35 $\mu\text{g}/\text{sample}$) was considered optimal in this example.

Example calculations:

Stock antibody concentration is 0.5 $\mu\text{g}/\mu\text{l}$ and desired concentration is 0.01 $\mu\text{g}/\mu\text{l}$ (50X dilution).

Reagents	Stock	Final	Volume (μl)
PBS	10X	1X	7.0
BSA	10%	2%	14.0
RNase Inhibitor	40 U/ μl	2 U/ μl	3.5
Tween-20	10%	0.1%	0.7

Reagents	Stock	Final	Volume (µl)
Antibody	0.5 µg/µl	0.1 µg/µl	1.4
DAPI Solution	100X	0.5X	0.4
Nuclease-free Water			43.0
Total			70.0

Stock antibody concentration is 0.5 µg/µl and desired concentration is 0.0025 µg/µl (200X dilution).

- This calculation requires pipetting a very small volume of antibody. Dilute the stock concentration first (for example, dilute 10X to 0.05 µg/µl) then proceed with the following reagent table:

Reagents	Stock	Final	Volume (µl)
PBS	10X	1X	7.0
BSA	10%	2%	14.0
RNase Inhibitor	40 U/µl	2 U/µl	3.5
Tween-20	10%	0.1%	0.7
Antibody	0.5 µg/µl	0.0025 µg/µl	1.4
DAPI Solution	100X	0.5X	0.4
Nuclease-free Water			43.0
Total			70.0

Example Fluorophore Conjugated Primary Antibody Dilution Series

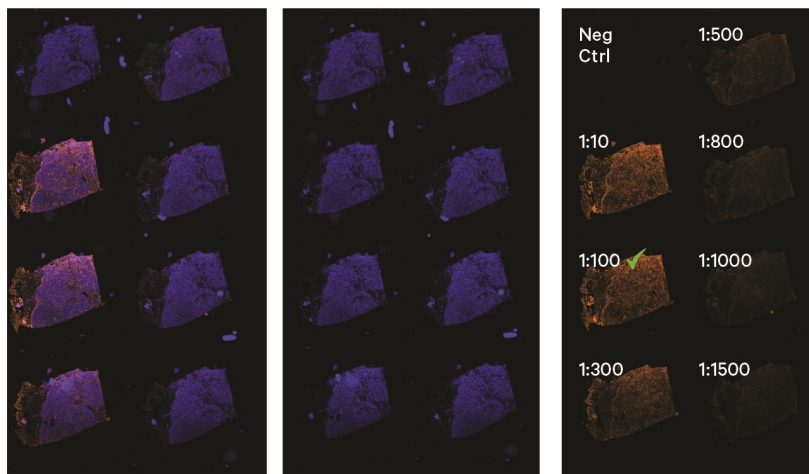

4.0 Preparation - Buffers

Consult the Visium HD Spatial Applications Protocol Planner (CG000698) for a list of third-party items.

For Deparaffinization

Items	Preparation & Handling
Prepare fresh weekly. Process two slides per jar. Process no more than 20 slides before replacing reagents. Alternatively, use a slide staining dish. Adjust volumes of deparaffinization solutions and water accordingly and ensure volume fully covers tissue.	
<input type="checkbox"/> Xylene	Label two Coplin jars as Xylene Jar 1 and 2. Dispense 30 ml xylene in each.
<input type="checkbox"/> 100% Ethanol	Label two Coplin jars as 100% Ethanol Jar 1 and 2. Dispense 30 ml 100% ethanol in each. Alternatively, use a 50-ml centrifuge tube or beaker.
<input type="checkbox"/> 96% Ethanol	Label two Coplin jars as 96% Ethanol Jar 1 and 2. Dispense 30 ml 96% ethanol in each. Alternatively, use a 50-ml centrifuge tube or beaker.
<input type="checkbox"/> 70% Ethanol	Label one Coplin jar as 70% Ethanol Jar. Dispense 30 ml 70% ethanol. Alternatively, use a 50-ml centrifuge tube or beaker.
<input type="checkbox"/> Milli-Q or UltraPure Water	Label one Coplin jar as WaterJar. Dispense 30 ml water. Alternatively, use a 50-ml centrifuge tube or beaker.



Use xylene-resistant dishes for immersion in xylene. Use xylene-resistant gloves or forceps for deparaffinization. Prepare fresh reagents every week.

For Staining

Items	Preparation & Handling
<input type="checkbox"/> 1X PBS	Prepare 50 ml of 1X PBS from 10X stock using nuclease-free water.
<input type="checkbox"/> 2X SSC	Prepare 1 ml of 2X SSC from 20X stock using nuclease-free water.
<input type="checkbox"/> 70% Ethanol	Optional, if performing TrueBlack Quenching. Prepare 1 ml of 70% Ethanol by diluting stock ethanol with nuclease-free water.

Items	Preparation & Handling
<input type="checkbox"/> Wash Buffer	Prepare Wash Buffer according to the appropriate table below, adding reagents in the order listed. Pipette mix 10x and centrifuge briefly. Maintain on ice.

If using a fluorophore conjugated primary antibody:

Wash Buffer	Stock	Final	1X (μ l)	2X +10% (μ l)	4X +10% (μ l)
<i>1X = 1 Tissue Slide Cassette Gasket</i>					
PBS	10X	1X	60.0	132.0	264.0
Tween-20	10%	0.4%	24.0	52.8	105.6
Nuclease-free Water	-	-	516.0	1,135.2	2,270.4
Total	-	-	600.0	1,320.0	2,640.0

If using a primary and secondary antibody:

Wash Buffer	Stock	Final	1X (μ l)	2X +10% (μ l)	4X +10% (μ l)
<i>1X = 1 Tissue Slide Cassette Gasket</i>					
PBS	10X	1X	120.0	264.0	528.0
Tween-20	10%	0.4%	48.0	105.6	211.2
Nuclease-free Water	-	-	1,032.0	2,270.4	4,540.8
Total	-	-	1,200.0	2,640.0	5,280.0

<input type="checkbox"/> 1X Blocking Buffer	Prepare Blocking Buffer on ice according to the appropriate table below, adding reagents in the order listed. Pipette mix 10x and centrifuge briefly. Maintain on ice.
---	--

1X Blocking Buffer	Stock	Final	1X (μ l)	2X +10% (μ l)	4X +10% (μ l)
PBS	10X	1X	10.0	22.0	44.0
BSA	10%	2%	20.0	44.0	88.0
RNase Inhibitor	40 U/ μ l	2 U/ μ l	2.5	5.5	11.0
Tween-20	10%	0.1%	1.0	2.2	4.4
Nuclease-free Water	-	-	66.5	146.3	292.6
Total	-	-	100.0	220.0	440.0

For Decrosslinking

Items	10x PN	Preparation & Handling	Storage
Equilibrate to room temperature			
<input type="checkbox"/>	Perm Enzyme B 3000553	Equilibrate to room temperature. Pipette mix, centrifuge briefly. DO NOT vortex.	-20°C
<input type="checkbox"/>	Decrosslinking Buffer B 2001094	Thaw in a thermomixer for 30 min at 37°C, 300 rpm with shaking. Cool to room temperature for 5 min. Vortex for 30 sec and centrifuge briefly. Alternatively, thaw in a water bath for 30 min at 37°C. Cool to room temperature for 5 min. Vortex for 30 sec and centrifuge briefly.*	-20°C
Obtain			
<input type="checkbox"/>	Nuclease-free Water -	-	Ambient
<input type="checkbox"/>	2X SSC -	Prepare 1 ml 2X SSC from 20X stock using nuclease-free water.	Ambient
<input type="checkbox"/>	1X PBS -	Prepare 1 ml 1X PBS from 10X stock using nuclease-free water.	Ambient
<input type="checkbox"/>	10% Tween-20 -	-	Ambient
<input type="checkbox"/>	8M Urea -	-	Ambient

For Coverslip Mounting

Items	Preparation & Handling				
<input type="checkbox"/> Mounting Medium	Invert to mix. Briefly centrifuge to remove bubbles.				
	Mounting Medium <i>1 slide = 1 Tissue Slide</i>	Stock	Final	1 Slide (μ l)	2 Slides +15% (μ l)
	Glycerol	100%	80%	120	276
	SlowFade Diamond	100%	20%	30	69
	Total	-	-	150	345

Protocol Overview

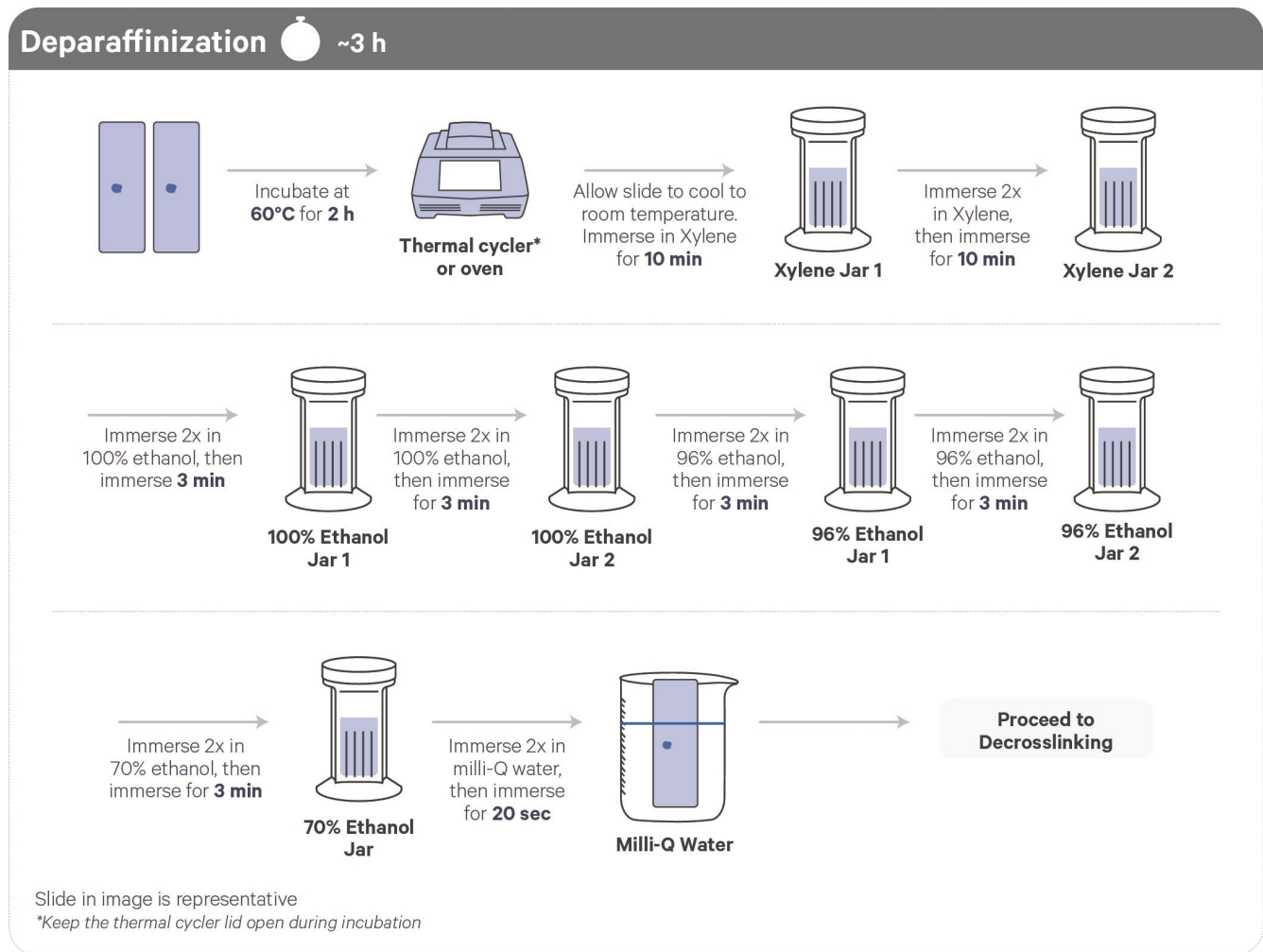

IF Staining & Imaging

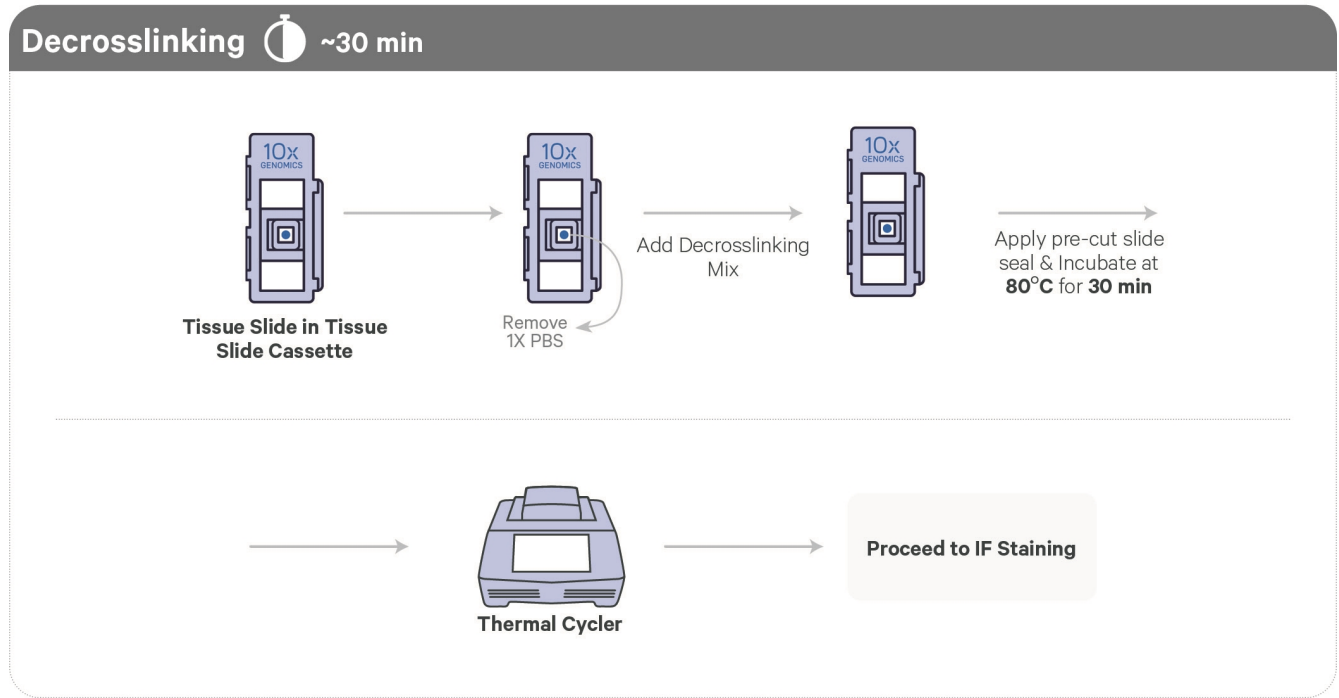

Immunofluorescence Staining – Fluorophore Conjugated Primary Antibodies 🕒 ~2 h

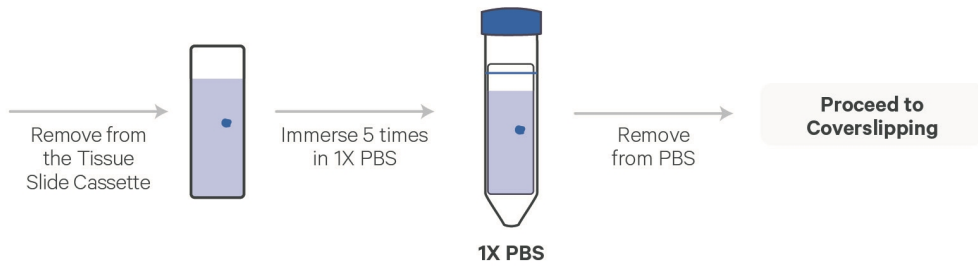
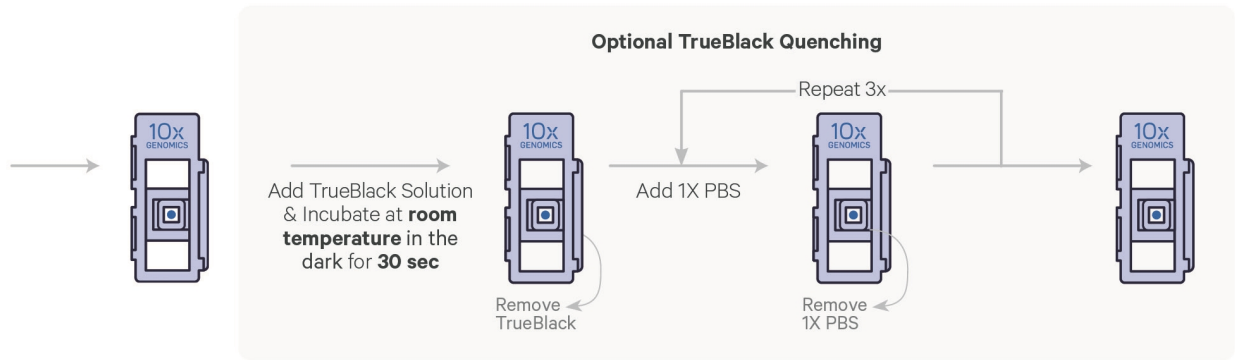
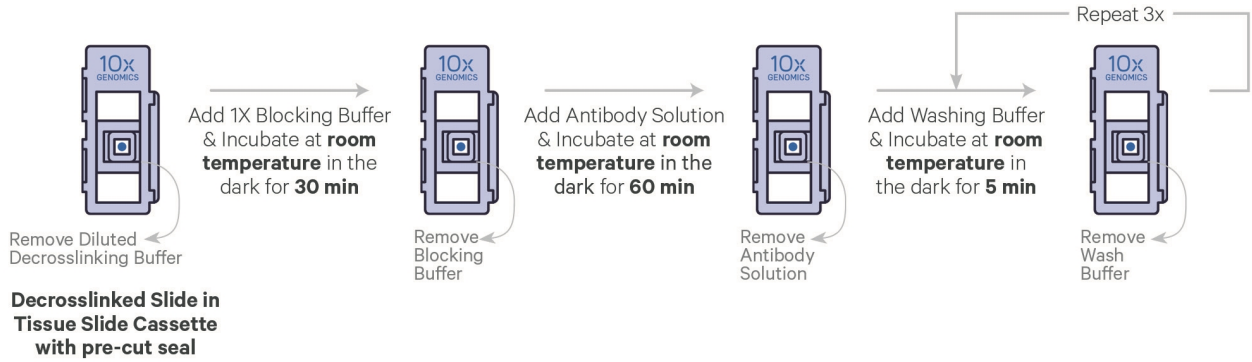

IF Staining & Imaging

Immunofluorescence Staining – Primary & Secondary Antibodies ~2.5 h

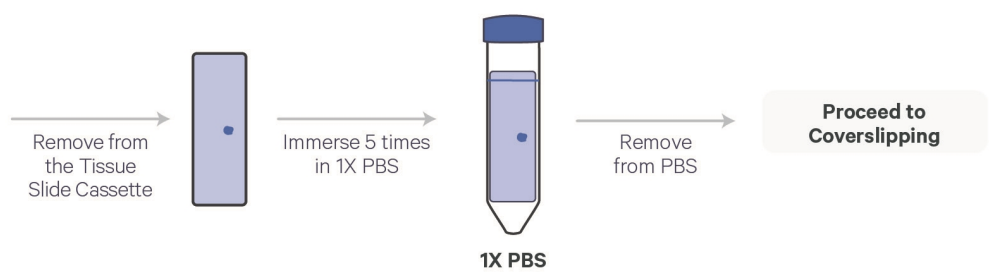
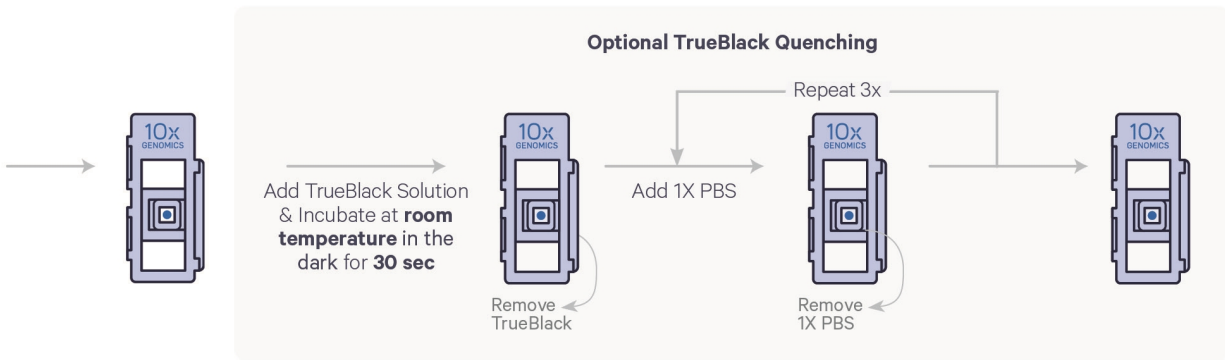
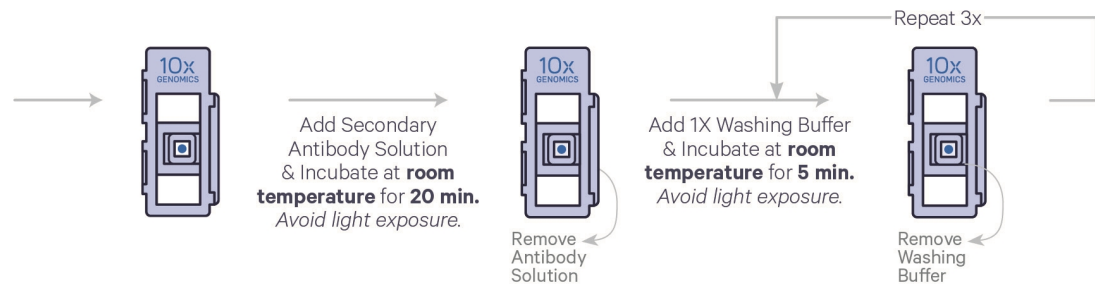
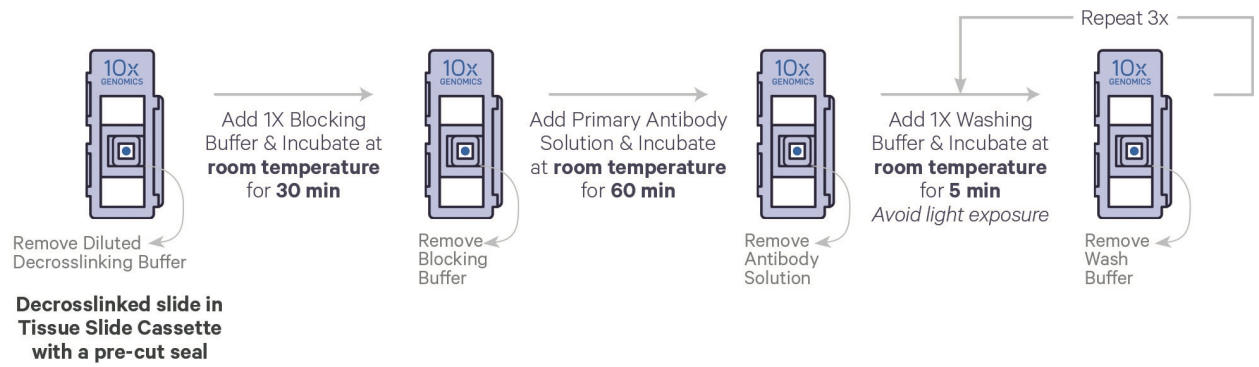

IF Staining & Imaging

4.1 Deparaffinization

Deparaffinization steps should be performed in a fume hood due to the hazardous nature of xylene.

- a. Retrieve slides with tissue sections from desiccator after overnight drying.
- b. Place slides in a rack sideways in a Section Dryer Oven and incubate uncovered at **60°C** for **2 h**. Keep oven lid closed during incubation.

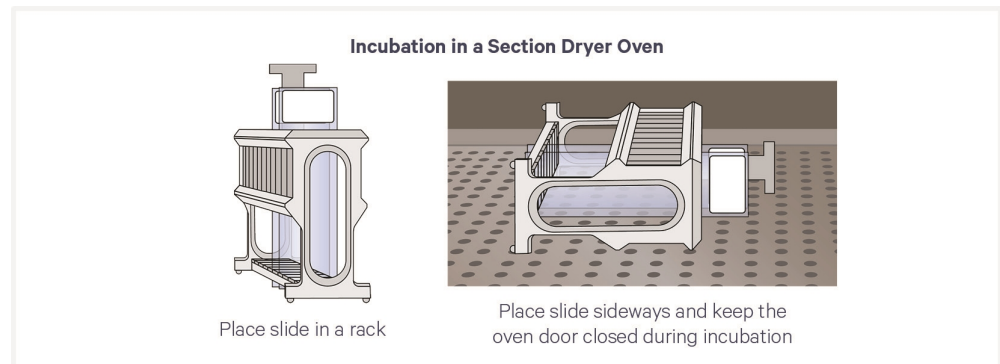

Alternatively, place a Low Profile Thermocycler Adapter on a thermal cycler set at **60°C**. Place slide on the Low Profile Thermocycler Adapter with the tissue side facing up and incubate **2 h** at **60°C**.



DO NOT close the thermal cycler lid.

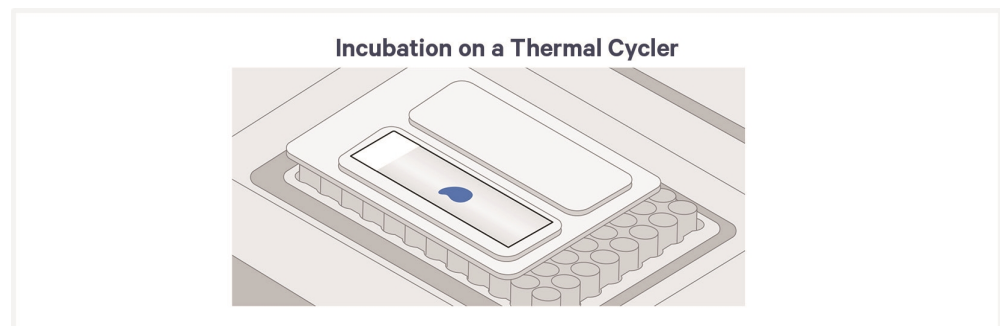

- c. Remove slides from the oven or thermal cycler and allow to cool down to room temperature for **5 min**.



When immersing slides in xylene, ensure that the tissue sections are completely submerged.

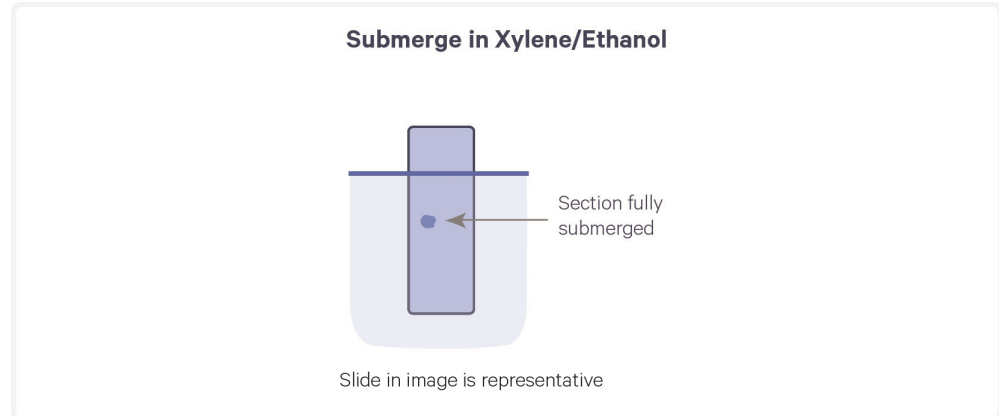

- d.** Gently immerse slides 2x in Xylene Jar 1, then immerse and incubate for **10 min.** Secure jar cap to prevent xylene loss.
- e.** Gently immerse slides 2x in Xylene Jar 2, then immerse and incubate for **10 min.** Secure jar cap to prevent xylene loss.
- f.** Gently immerse slides 2x in 100% Ethanol Jar 1, then immerse and incubate for **3 min.**
- g.** Gently immerse slides 2x in 100% Ethanol Jar 2, then immerse and incubate for **3 min.**
- h.** Gently immerse slides 2x in 96% Ethanol Jar 1, then immerse and incubate for **3 min.**
- i.** Gently immerse slides 2x in 96% Ethanol Jar 2, then immerse and incubate for **3 min.**
- j.** Gently immerse slides 2x in 70% Ethanol Jar, then immerse and incubate for **3 min.**
- k.** Gently immerse slides 2x in Water Jar, then immerse and incubate for **20 sec.**
- l.** Allow slides to air dry and proceed to Decrosslinking.

4.2 Decrosslinking

- a. Prepare the thermal cycler with the following incubation protocol and start the program.

Lid Temperature	Reaction Volume	Run Time
80°C	100 µl	40 min
Step	Temperature	Time hh:mm:ss
Hold	22°C	Hold
Decrosslinking	80°C	00:30:00
Re-equilibrate	22°C	00:10:00
Hold	22°C	Hold

- b. Prepare Diluted Perm Enzyme B according to the table below. Add reagents in the order listed. Mix thoroughly with a 1-ml pipette set to 600 µl. Maintain at room temperature.

Diluted Perm Enzyme B	Stock	Final	Total Amount (µl)
1X PBS	-	-	998.0
Perm Enzyme B <i>(Maintain at room temperature. Pipette mix, centrifuge briefly. DO NOT vortex).</i>	-	-	2.0
Total	-	-	1,000.0

- c. Prepare Decrosslinking Mix according to the table below. Add reagents in the order listed. Pipette mix thoroughly. Centrifuge briefly. Maintain at room temperature.

Decrosslinking Mix <i>1 slide = 1 Tissue Slide</i>	Stock	Final	1 slide (µl)	2 slides + 10% (µl)	4 slides + 10% (µl)
Decrosslinking Buffer B	-	-	92.4	203.4	407.0
Urea	8 M	0.5 M	6.3	13.8	27.5
Diluted Perm Enzyme B	-	-	1.3	2.8	5.5
Total	-	-	100.0	220.0	440.0

- d. Place the slide in a Tissue Slide Cassette.

See Visium Cassette S3 Quick Reference Card (CG000730) for assembly instructions. Practice assembly with a blank slide.

- e. Add **100 μ l** 1X PBS along the side of the wells.
- f. Remove 1X PBS from the wells.
- g. Add **100 μ l** Decrosslinking Mix along the side of the wells
- h. Apply a new slide seal on the cassette and place the cassette on the Low Profile Thermocycler Adapter.
- i. Close and tighten thermal cycler lid. Skip Pre-equilibrate step and initiate Decrosslinking.
- j. After decrosslinking is complete, remove the cassette from the Low Profile Thermocycler Adapter and place on a flat, clean work surface.
- k. Peel back slide seal and using a pipette, remove all Decrosslinking Mix from the well corners.
- l. Add **150 μ l** 1X PBS along the side of the wells to uniformly cover the tissue sections, without introducing bubbles.
- m. Proceed **immediately** to appropriate Immunofluorescence Staining protocol.

4.3 Immunofluorescence Staining



Choose appropriate staining protocol depending upon the antibodies used. If using a primary and secondary antibody, proceed directly to [4.5 Immunofluorescence Staining - Primary & Secondary Antibodies](#) on page 75.



Antibody dilution may vary depending on the antibody, ranging from 1:50 down to 1:1000. Antibody volumes will depend on concentrations determined during antibody optimization.

4.4 Immunofluorescence Staining - Fluorophore Conjugated Primary Antibodies

- a. Prepare Antibody Solution on ice, adding reagents in the order listed. Pipette mix 10x and centrifuge briefly. Maintain on ice.

Antibody Solution	Stock	Final	1X (μl)	2X +10% (μl)	4X +10% (μl)
<i>1X = 1 Tissue Slide Cassette Gasket</i>					
PBS	10X	1X	7.0	15.4	30.8
BSA	10%	2%	14.0	30.8	61.6
RNase Inhibitor	40U/μl	2U/μl	3.5	7.7	15.4
Tween-20	10%	0.1%	0.7	1.5	3.1
Antibody #1	Variable	Variable	Variable	Variable	Variable
Antibody #2 (Optional)	Variable	Variable	Variable	Variable	Variable
Antibody #3 (Optional)	Variable	Variable	Variable	Variable	Variable
DAPI Solution	100X	0.5X	0.4	0.8	1.5
Nuclease-free Water	Variable	Variable	Variable	Variable	Variable
Total	-	-	70.0	154.0	308.0

- b. *Optional* - Prepare 1X TrueBlack Solution according to the appropriate table, adding reagents in the order listed. Pipette mix 10x and centrifuge briefly. Maintain at room temperature.

1X TrueBlack Solution	Stock	Final	1X (μl)	2X +10% (μl)	4X +10% (μl)
<i>1X = 1 Tissue Slide Cassette Gasket</i>					
TrueBlack Lipofuscin Quencher	20X	1X	3.5	7.7	15.4
70% Ethanol	-	-	66.5	146.3	292.6
Total	-	-	70.0	154.0	308.0

- c. Remove all 1X PBS from the wells.
- d. Add **100 μl** 1X Blocking Buffer along the side of the wells.
- e. Re-apply Visium Slide Seal to Tissue Slide Cassette.
- f. Incubate for **30 min** at **room temperature**.
- g. Peel back slide seal from the cassette and remove all Blocking Buffer from the wells.
- h. Add **70 μl** Antibody Solution along the side of the wells. Tap gently to ensure uniform coverage.
- i. Re-apply slide seal to the cassette.
- j. Incubate for **1 h** at **room temperature** in the dark.
- k. Peel back slide seal and remove Antibody Solution.
 - l. Add **150 μl** Wash Buffer along the side of the wells.
- m. Incubate for **5 min** at **room temperature**.
- n. Remove all Wash Buffer from the wells.
- o. Repeat l-n three more times for a total of four washes.
- p. *Optional* - TrueBlack Quenching
 - Add **70 μl** 1X TrueBlack Solution along the side of the wells. Tap cassette gently to ensure uniform coverage.
 - Incubate for **30 sec** at **room temperature**.
 - Remove all 1X TrueBlack Solution from the wells.
 - Add **150 μl** 1X PBS along the side of the wells.
 - Remove all PBS from the wells.
 - Repeat PBS washes three more times for a total of four washes.
- q. Remove slide from cassette.



See Tips & Best Practices for removal instructions.

- r. Gently immerse slide 5x in 1X PBS in 50-ml centrifuge tube. If processing multiple slides, use a separate 50-ml centrifuge tube filled with PBS for each slide.
- s. Remove slide from the PBS and proceed **immediately** to Coverslip Mounting.



DO NOT let the slide dry.

4.5 Immunofluorescence Staining - Primary & Secondary Antibodies

- a. Prepare Primary Antibody Solution on ice, adding reagents in the order listed. Pipette mix 10x and centrifuge briefly. Maintain on ice.

Primary Antibody Solution	Stock	Final	1X (μ l)	2X +10% (μ l)	4X +10% (μ l)
<i>1X = 1 Tissue Slide Cassette Gasket</i>					
PBS	10X	1X	7.0	15.4	30.8
BSA	10%	2%	14.0	30.8	61.6
RNase Inhibitor	40U/ μ l	2U/ μ l	3.5	7.7	15.4
Tween-20	10%	0.1%	0.7	1.5	3.1
Antibody #1	Variable	Variable	Variable	Variable	Variable
Antibody #2 (Optional)	Variable	Variable	Variable	Variable	Variable
Antibody #3 (Optional)	Variable	Variable	Variable	Variable	Variable
Nuclease-free Water	Variable	Variable	Variable	Variable	Variable
Total	-	-	70.0	154.0	308.0

- b. Prepare Secondary Antibody Solution on ice, adding reagents in the order listed. Pipette mix 10x and centrifuge briefly. Maintain on ice.

Secondary Antibody Solution	Stock	Final	1X (μ l)	2X +10% (μ l)	4X +10% (μ l)
<i>1X = 1 Tissue Slide Cassette Gasket</i>					
PBS	10X	1X	7.0	15.4	30.8
BSA	10%	2%	14.0	30.8	61.6
RNase Inhibitor	40U/ μ l	2U/ μ l	3.5	7.7	15.4
Tween-20	10%	0.1%	0.7	1.5	3.1

Secondary Antibody Solution	Stock	Final	1X (μl)	2X +10% (μl)	4X +10% (μl)
<i>1X = 1 Tissue Slide Cassette Gasket</i>					
Antibody #1	Variable	Variable	Variable	Variable	Variable
Antibody #2 (Optional)	Variable	Variable	Variable	Variable	Variable
Antibody #3 (Optional)	Variable	Variable	Variable	Variable	Variable
DAPI Solution	100X	1X	0.7	1.5	3.1
Nuclease-free Water	Variable	Variable	Variable	Variable	Variable
Total	-	-	70.0	154.0	308.0



Antibody dilution can change depending on the antibody, ranging from 1:10 up to 1:1500. Antibody volumes will depend on concentrations determined during antibody optimization.

- c. Optional** - Prepare 1X TrueBlack Solution according to the appropriate table, adding reagents in the order listed. Pipette mix 10x and centrifuge briefly. Maintain at room temperature.

1X TrueBlack Solution	Stock	Final	1X (μl)	2X +10% (μl)	4X +10% (μl)
<i>1X = 1 Tissue Slide Cassette Gasket</i>					
TrueBlack Lipofuscin Quencher	20X	1X	3.5	7.7	15.4
70% Ethanol	-	-	66.5	146.3	292.6
Total	-	-	70.0	154.0	308.0

- d.** Remove all 1X PBS from the wells.
- e.** Add **100 μl** 1X Blocking Buffer along the side of the wells.
- f.** Re-apply Visium Slide Seal to Tissue Slide Cassette.
- g.** Incubate for **30 min** at **room temperature**.
- h.** Peel back slide seal from the cassette and remove all Blocking Buffer from the wells.
- i.** Add **70 μl** Primary Antibody Solution along the side of the wells. Tap gently to ensure uniform coverage.

- j. Re-apply slide seal to the cassette.
- k. Incubate for **1 h** at **room temperature** in the dark.
- l. Peel back slide seal and remove Primary Antibody Solution.
- m. Add **150 μ l** Wash Buffer along the side of the wells.
- n. Incubate for **5 min** at **room temperature**.
- o. Remove all Wash Buffer from the wells.
- p. Repeat m-o three more times for a total of four washes.
- q. Add **70 μ l** Secondary Antibody Solution along the side of the wells. Tap gently to ensure uniform coverage.
- r. Re-apply slide seal to the cassette.
- s. Incubate for **20 min** at **room temperature** in the dark.
- t. Peel back slide seal and remove Secondary Antibody Solution.
- u. Add **150 μ l** Wash Buffer along the side of the wells.
- v. Incubate for **5 min** at **room temperature**.
- w. Remove all Wash Buffer from the wells.
- x. Repeat u-w three more times for a total of four washes.
- y. *Optional* - TrueBlack Quenching
 - Add **70 μ l** 1X TrueBlack Solution along the side of the wells. Tap cassette gently to ensure uniform coverage.
 - Incubate for **30 sec** at **room temperature**.
 - Remove all 1X TrueBlack Solution from the wells.
 - Add **150 μ l** 1X PBS along the side of the wells.
 - Remove all PBS from the wells.
 - Repeat PBS washes three more times for a total of four washes.
- z. Remove slide from cassette.

TIPS See *Tips & Best Practices for removal instructions*.

- aa. Gently immerse slide 5x in 1X PBS in a 50-ml centrifuge tube. If processing multiple slides, use a separate 50-ml centrifuge tube filled with PBS for each slide.
- ab. Remove slide from the PBS and proceed **immediately** to Coverslip Mounting.



DO NOT let the slide dry.

4.6 Coverslip Mounting

- Place slides on a flat, clean, nonabsorbent work surface. Some residual droplets may remain.
- Using a **wide-bore** pipette tip, add **100–150 μ l** Mounting Medium to cover all tissue sections on slides uniformly.
- Apply the coverslip at an angle on one end of the slides. Slowly lower the coverslip, without introducing bubbles. Allow Mounting Medium to spread and settle.

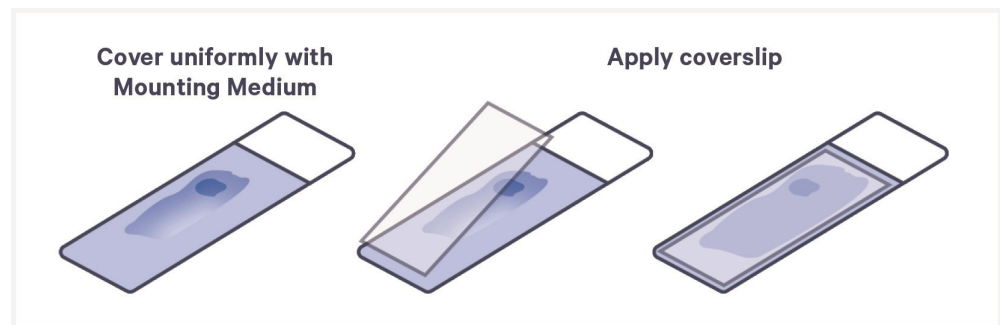

- Remove any large excess of Mounting Medium by carefully wicking away from the edge of the coverslip using a lint-free laboratory wipe. Do not move the coverslip and disturb the tissue.
- Immediately** proceed with imaging or store slides laying flat in a slide mailer or a slide holder. Store slides at **4°C** for up to **24 h**. Ensure that slides are laid flat to prevent loss of mounting medium.



DO NOT let the attached coverslip dry out.

DO NOT use Cytoseal or nail polish for securing the coverslip.

4.7 Imaging

- Image tissue section of interest at the desired magnification using brightfield imaging settings. Consult the Visium HD Spatial Applications Imaging Guidelines Technical Note (CG000688) for additional information.
- Proceed **immediately** to Coverslip Removal.

4.8 Coverslip Removal

- Dispense **800 ml** PBS in a beaker. Up to 10 slides may be processed using this beaker.
- Immerse slides sideways in the beaker containing **800 ml** PBS with the coverslipped surface fully sideways to prevent the coverslip from dragging across the tissue.
- Hold slides in PBS until the coverslip slowly separates away from the slide.



To avoid tissue section damage or detachment, DO NOT move the slide up and down, shake forcibly, or manually move the coverslip.

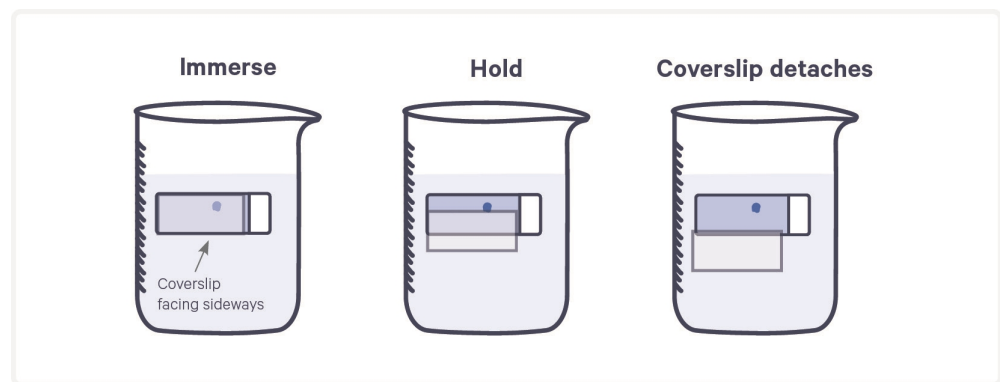

- Gently immerse slides 30x in PBS to ensure all Mounting Medium is removed.
- Wipe the back of the slide with a lint-free laboratory wipe. Place on a flat, clean, nonabsorbent work surface and air dry for **5 min**.
- Proceed **immediately** to step g or store slides laying flat in a slide mailer or slide holder at **4°C** in the dark with desiccant for up to **2 weeks**. Ensure slides do not touch one another and that desiccant does not come in contact with the tissue slide.
- Place the slide in a new Tissue Slide Cassette.
- Add **100 µl** PBS along the side of the wells.
- Apply a new pre-cut slide seal to the cassette.
- Proceed immediately to Visium HD Spatial Gene Expression Reagent Kits User Guide (CG000685).



Troubleshooting

Ideal Floating Time Determination

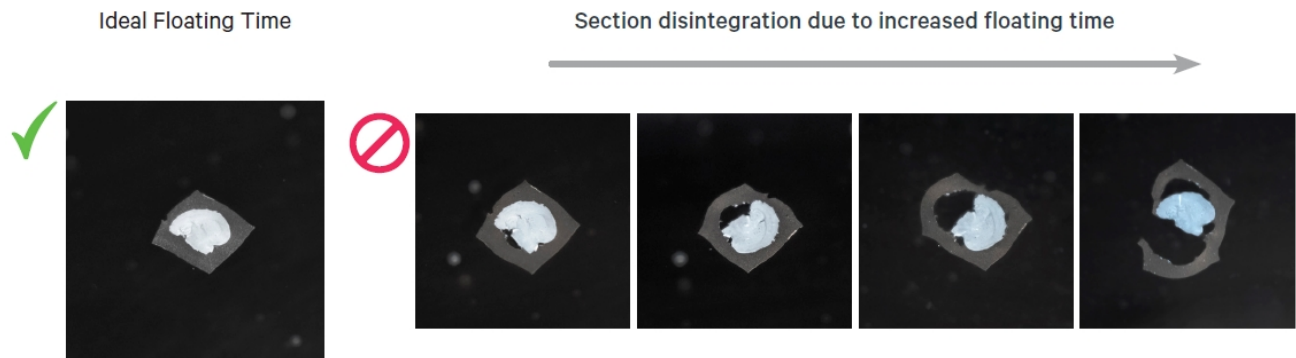

Incorrect Placement of Tissue Sections

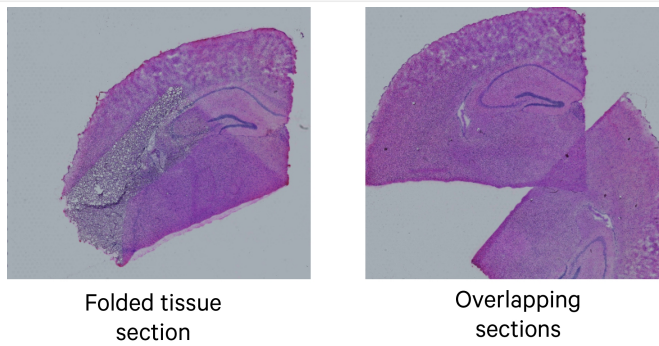

Common Artifacts that cause Detachment

Wrinkles

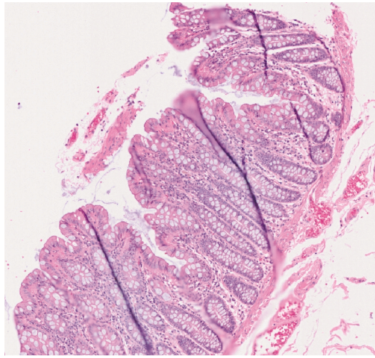

Causes

- Section compression (due to warm block or dull blade) during sectioning leads to wrinkle formation. These wrinkles become permanent when placed in the water bath.
- Accumulated wax or static electricity on microtome parts also contribute to section compression.

Troubleshooting

- Ensure that the block is well hydrated.
- Adjust temperature down and increase float time.
- Gently and gradually lay FFPE sections onto water bath surface, lengthwise.
- Utilize a new blade.
- Ensure microtome is cleaned with 100% ethanol to minimize static and section compression (bunching on blade).

Folds

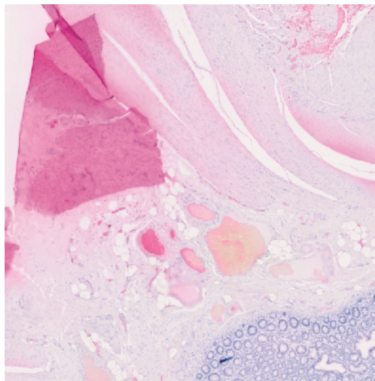

Causes

- Mostly happens when placing the section on the water bath especially when the section is uneven.
- If the fold is at the edge this most likely can happen during sectioning or mounting on the slide.

Troubleshooting

- Gently and gradually lay FFPE ribbons or sections onto water bath surface, lengthwise.
- If sections curl during sectioning, gently flatten them with a brush before floating.

Venetian Blinds or Shatter

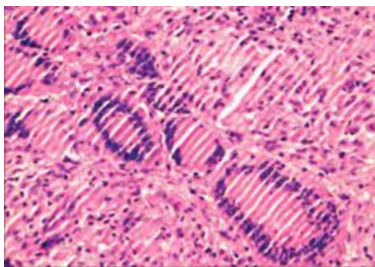

Causes

- Parallel lines in the section mostly appear due to dry tissue because of under-hydration of the block in the ice bath.
- Less likely due to dull blade or loose parts of the microtome.

Troubleshooting

- Increase incubation time of the block in an ice bath.
- Tighten down components of microtome and make sure the blade is at a correct angle.

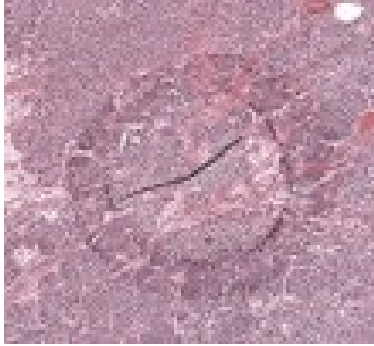
Common Artifacts that cause Detachment**Air Bubbles****Causes**

- Air bubbles from the bottom of the water bath can rise and stick under the section.

Troubleshooting

- Using a brush, gently remove the bubbles from the bottom of the water bath before floating the sections.

Waves

May be block-specific and easily observed under the microscope right after the section is picked up from the water bath. Minor waves can disappear after longer flotation in the water bath. Larger waves can create wrinkles or folds that are permanent after drying of the section.

Causes

- Tissue incompletely infiltrated with wax absorbs water faster during the hydration step. When sections from such blocks are floated, the parts that absorbed enough water will have difficulty flattening and become wavy.

Troubleshooting

- Chill the block on a cold block or on ice avoiding contact with water.
- Submerge the block for 5–15 min in the ice bath for gentle hydration.
- Increase flotation time and/or temperature of the water bath.

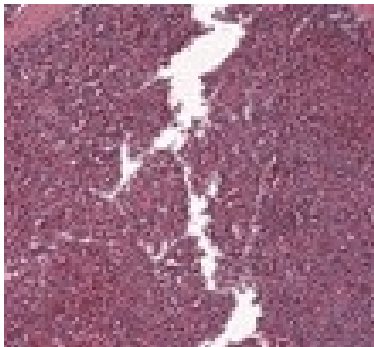
Cracks**Causes**

- Dry and overprocessed tissue can crack during sectioning.
- The cracks that are created before tissue embedding will be filled with wax when section is observed under the microscope after sectioning and wax will be washed away after deparaffinization or H&E staining.

Troubleshooting

- Prolonged hydration on the ice bath will most likely reduce the cracks.
- There is no solution for cracks created before tissue was embedded in wax.

Common Artifacts that cause Detachment**Sweating****Causes**

- Inadequate dehydration or underprocessing of the tissue causes parts of the section to attract water and create this blistering effect. Such sections can disintegrate in the water bath.
- The blisters consist of:
 - Xylene or xylene substitutes if the cause is underprocessing and insufficient removal of xylene or
 - Water droplets if the cause is inadequate dehydration.

Troubleshooting

- Be cautious about how long the block is kept in an ice bath. Long incubation time in an ice bath can impact section quality and thus should be avoided.
- Long flotation time in the water bath should be avoided.

Water Retention**Causes**

- Sections from tissues that are underprocessed or excessively hydrated before sectioning may retain water under the section mounted on a slide.
- Water will accumulate under section and cause uneven drying ultimately leading to detachment.

Troubleshooting

- Gently flicking the slide will help to get rid of the water. This is one of the most overlooked cause of detachment.
- Use a fan to assist in drying.

Disintegrating/Exploding Section**Causes**

- Sections from tissues that are underprocessed and not sufficiently infiltrated with wax can rapidly absorb water and explode or gradually disintegrate in the water bath.
- Tissues that are not sufficiently dehydrated can show similar phenotypes.
- Floating at high temperatures (42-50°C) can exacerbate the disintegration.

Troubleshooting

- Chilling of the block should be mostly performed on ice or cold block (30-60 min).
- Exposure to water in an ice bath during chilling should be kept to a minimum (5-10 min).
- Flotation water bath temperature should be lowered to 38-40°C.

Common Artifacts that cause Detachment**Sweating****Causes**

- Inadequate dehydration or underprocessing of the tissue causes parts of the section to attract water and create this blistering effect. Such sections can disintegrate in the water bath.
- The blisters consist of:
 - Xylene or xylene substitutes if the cause is underprocessing and insufficient removal of xylene or
 - Water droplets if the cause is inadequate dehydration.

Troubleshooting

- Be cautious about how long the block is kept in an ice bath. Long incubation time in an ice bath can impact section quality and thus should be avoided.
- Long flotation time in the water bath should be avoided.

Water Retention**Causes**

- Sections from tissues that are underprocessed or excessively hydrated before sectioning may retain water under the section mounted on a slide.
- Water will accumulate under section and cause uneven drying ultimately leading to detachment.

Troubleshooting

- Gently flicking the slide will help to get rid of the water. This is one of the most overlooked cause of detachment.
- Use a fan to assist in drying.

Disintegrating/Exploding Section**Causes**

- Sections from tissues that are underprocessed and not sufficiently infiltrated with wax can rapidly absorb water and explode or gradually disintegrate in the water bath.
- Tissues that are not sufficiently dehydrated can show similar phenotypes.
- Floating at high temperatures (42-50°C) can exacerbate the disintegration.

Troubleshooting

- Chilling of the block should be mostly performed on ice or cold block (30-60 min).
- Exposure to water in an ice bath during chilling should be kept to a minimum (5-10 min).
- Flotation water bath temperature should be lowered to 38-40°C.

H&E Staining Troubleshooting

Tissue Detachment Ensure compatible blank slides are used to minimize tissue detachment. Consult the Visium HD Protocol Planner (CG000698). Tissues with large amounts of connective tissue (like breast or colon) should be placed on Schott Nexterion Slide H 3D Slides (Schott North America, PN-1800434) to minimize risk of tissue detachment

Bubbles Avoid bubble formation during coverslip mounting. Bubbles can be mitigated by applying the coverslip at an angle and slowly lowering it onto the slide, allowing air to escape. Briefly centrifuge mounting medium to remove bubbles before use. Avoid introducing bubbles when pipetting mounting medium onto slide.

Bubbles may cause blackening of tissue. Slide in image is representative.

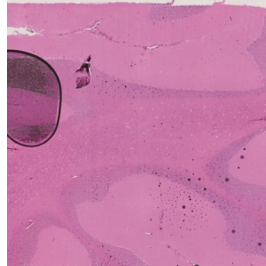

Uneven Staining **Causes** Ensure fresh staining reagents are applied to the tissue uniformly and adequate washes are performed. A gentle tap may help reagents spread uniformly. Consider filtering hematoxylin.

Slide in image is representative.

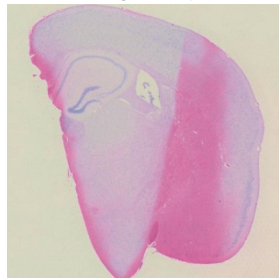

Incorrect Staining Protocol The staining protocol in this handbook was optimized for tissues that will be processed with the Visium HD assay. Using an alternative H&E staining protocol may result in reduced staining performance.

In the mouse embryo examples below, the Visium HD H&E protocol results in better contrast between the hematoxylin (blue) stained nuclei and the eosin (pink) stained cytoplasm compared to the incorrect protocol.

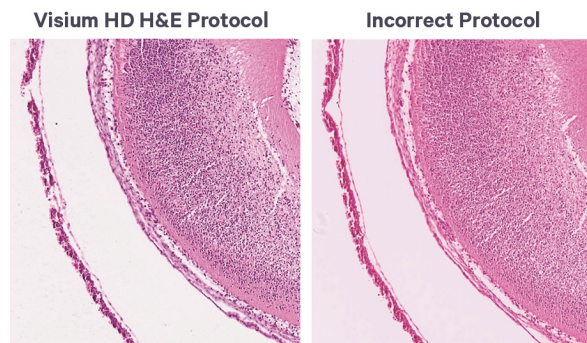

IF Staining Troubleshooting

Weak Antibody Signal

Weak antibody signal in areas of the tissue where strong signal is expected may indicate that a nonideal concentration of antibody was used. Perform antibody optimization to determine the optimal concentration.

Good Signal - DAPI and Antibody Stain

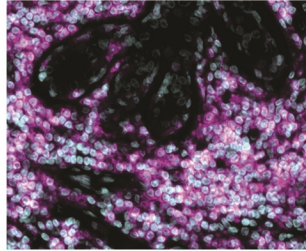

Good Signal - Antibody Stain Only

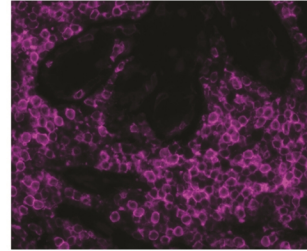

Weak Signal - DAPI and Antibody Stain

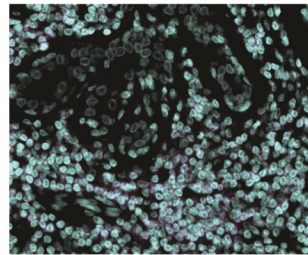

Weak Signal - Antibody Stain Only



Appendix

DV200 Performance and Recommendations

DV200 is a broad measurement of RNA quality and is influenced by factors including:

- Tissue block age, type and composition
- Region selected for RNA extraction
- Presence of diseased or necrotic regions
- Depth of section
- Fixation method
- Miscellaneous upstream tissue handling and processing

10x Genomics recommends that the tissues used with the Visium HD Spatial Gene Expression should have a DV200 of >30%. For more information on DV200, consult the Appendix of the Visium CytAssist Spatial Gene Expression for FFPE – Tissue Preparation Guide (CG000518).